

SOLVED PAPER

AIIMS - 2012★

Time : 3½ Hours

Max. Marks : 200

PHYSICS

1. Which of the following current must be zero in an unbiased PN junction diode?
 - (a) Current due to majority charge carriers (both electrons and holes).
 - (b) Current due to minority charge carriers (both electrons and holes).
 - (c) Current due to majority and minority charge carriers.
 - (d) Current due to majority and minority charge carriers (only holes).
2. In an AC circuit, voltage $V = V_0 \sin \omega t$ and inductor L is connected across the circuit. Then the instantaneous power will be
 - (a) $\frac{V_0^2}{2\omega L} \sin \omega t$
 - (b) $\frac{-V_0^2}{2\omega L} \sin \omega t$
 - (c) $\frac{-V_0^2}{2\omega L} \sin 2\omega t$
 - (d) $\frac{V_0^2}{\omega L} \sin 2\omega t$
3. Two sinusoidal waves of intensity I having same frequency and same amplitude interferes constructively at a point. The resultant intensity at a point will be
 - (a) I
 - (b) $2I$
 - (c) $4I$
 - (d) $8I$
4. In a convex lens of focal length F , the minimum distance between an object and its real image must be
 - (a) $3F$
 - (b) $4F$
 - (c) $\frac{3}{2}F$
 - (d) $2F$
5. In Young's double slit experiment, fringe order is represented by m , then fringe width is
 - (a) Independent of m .
 - (b) Directly proportional to m .
 - (c) Directly proportional to $(2m + 1)$.
 - (d) Inversely proportional to $(2m + 1)$.
6. Half life of a radio-active element is 8 years, how much amount will be present after 32 years?
 - (a) $\frac{1}{4}$
 - (b) $\frac{1}{8}$
 - (c) $\frac{1}{16}$
 - (d) $\frac{1}{32}$

7. In the given circuit, the voltage across the load is maintained at 12 V. The current in the zener diode varies from 0-50 mA. What is the maximum wattage of the diode?

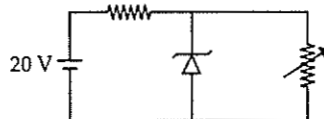

- (a) 12 W
 - (b) 6 W
 - (c) 0.6 W
 - (d) 1.2 W
8. A photon is incident having frequency $1 \times 10^{14} \text{ sec}^{-1}$. Threshold frequency of metal is $5 \times 10^{13} \text{ sec}^{-1}$. Find the kinetic energy of the ejected electron.
 - (a) $3.3 \times 10^{-21} \text{ J}$
 - (b) $6.6 \times 10^{-21} \text{ J}$
 - (c) $3.3 \times 10^{-20} \text{ J}$
 - (d) $6.6 \times 10^{-20} \text{ J}$
 9. In a given series LCR circuit $R = 4 \Omega$, $X_L = 5 \Omega$ and $X_C = 8 \Omega$, the current
 - (a) Leads the voltage by $\tan^{-1}(3/4)$.
 - (b) Leads the voltage by $\tan^{-1}(5/8)$.
 - (c) Lags the voltage by $\tan^{-1}(3/4)$.
 - (d) Lags the voltage by $\tan^{-1}(5/8)$.
 10. A wire of mass 100 g, length 1 m and current 5 A is balanced in mid air by a magnetic field B , then find the value of B .
 - (a) 0.2 T
 - (b) 0.1 T
 - (c) 0.5 T
 - (d) 0.6 T
 11. Dimensional formula of ΔQ , heat supplied to the system is given by
 - (a) $[M^1 L^2 T^{-2}]$
 - (b) $[M^1 L^1 T^{-2}]$
 - (c) $[M^1 L^2 T^{-1}]$
 - (d) $[ML^1 T^{-1}]$
 12. A toroid with mean radius r_0 , diameter $2a$ have N turns carrying current I . What is the magnetic field B inside the toroid?
 - (a) $\frac{NI}{2\pi r_0}$
 - (b) $\frac{NI}{2\pi(r_0 + a)}$
 - (c) $\frac{NI}{\pi(r_0 + a)}$
 - (d) zero
 13. Identify incorrect for electric charge q
 - (a) quantised
 - (b) conserved
 - (c) additive
 - (d) non-transferable.

★ Based on memory. Courtesy : Allen Career Institute, Kota (Rajasthan)

14. Which of the following parameter in the series LCR circuit is analogous to driving force $F(t)$ in mechanics?
- (a) $\frac{V_0}{L}$ (b) inductance L
 (c) capacitance C (d) voltage V_0
15. The minimum magnetic dipole moment of electron in hydrogen atom is
- (a) $\frac{eh}{2\pi m}$ (b) $\frac{eh}{4\pi m}$
 (c) $\frac{eh}{\pi m}$ (d) 0
16. A 4 kg roller is attached to a massless spring of spring constant $k = 100$ N/m. It rolls without slipping along a frictionless horizontal road. The roller is displaced from its equilibrium position by 10 cm and then released. Its maximum speed will be
- (a) 0.5 m s^{-1} (b) 0.6 m s^{-1}
 (c) 0.4 m s^{-1} (d) 0.8 m s^{-1}
17. Total energy of the electron in hydrogen atom above 0 eV leads to
- (a) continuation of energy states.
 (b) large number of discrete ionised states.
 (c) balmer series. (d) paschen series.
18. Two wires carrying
- (a) Parallel current repel each other.
 (b) Antiparallel current attract each other.
 (c) Antiparallel current repel each other.
 (d) Equal magnitudes of antiparallel current attract each other.
19. A particle is thrown vertically upwards with velocity 11.2 km s^{-1} from the surface of earth. Calculate its velocity at height $3R$. Where R is the radius of earth.
- (a) $\approx 9.25 \text{ km s}^{-1}$ (b) $\approx 5.6 \text{ km s}^{-1}$
 (c) $\approx 11.2 \text{ km s}^{-1}$ (d) $\approx 4.3 \text{ km s}^{-1}$
20. Gamma decay takes place
- (a) Prior to alpha decay.
 (b) Prior to beta decay.
 (c) Prior to positron decay.
 (d) Due to de-excitment of nuclear levels.
21. Calculate the kinetic energy of the electron having wavelength 1 nm.
- (a) 2.1 eV (b) 3.1 eV
 (c) 1.5 eV (d) 4.2 eV
22. A spherical body of diameter D is falling in viscous medium. Its terminal velocity is proportional to
- (a) $V_t \propto D^{1/2}$ (b) $V_t \propto D^{3/2}$
 (c) $V_t \propto D^2$ (d) $V_t \propto D^{5/2}$
23. Electric field outside a long wire carrying charge q is proportional to
- (a) $\frac{1}{r}$ (b) $\frac{1}{r^2}$
 (c) $\frac{1}{r^{3/5}}$ (d) $\frac{1}{r^{3/2}}$
24. If 2 kg mass is rotating on a circular path of radius 0.8 m with angular velocity of 44 rad/sec. If radius of the path becomes 1 m, then what will be the value of angular velocity?
- (a) 28.16 rad/sec (b) 19.28 rad/sec
 (c) 8.12 rad/sec (d) 35.26 rad/sec
25. A light ray is incident on a glass slab, it is partially reflected and partially transmitted. Then the reflected ray is
- (a) completely polarised and highly intense.
 (b) partially polarised and poorly intense.
 (c) partially polarised and highly intense.
 (d) completely polarised and poorly intense.
26. An electron projected with velocity $\vec{v} = v_0 \hat{i}$ in the electric field $\vec{E} = E_0 \hat{j}$. Trace the path followed by the electron E_0 .
- (a) Parabola (b) Circle
 (c) Straight line in $+y$ direction.
 (d) Straight line in $-y$ direction.
27. Find out the correct relation for the dependance of change in acceleration due to gravity on the angle at the latitude, due to rotation of earth
- (a) $dg \propto \cos\phi$ (b) $dg \propto \cos^2\phi$
 (c) $dg \propto \cos^{3/2}\phi$ (d) $dg \propto \frac{1}{\cos\phi}$
28. Two conductors having same width and length, thickness d_1 and d_2 , thermal conductivity K_1 and K_2 are placed one above the another. Find the equivalent thermal conductivity.
- (a) $\frac{(d_1 + d_2)(K_1 d_2 + K_2 d_1)}{2(K_1 + K_2)}$
 (b) $\frac{(d_1 - d_2)(K_1 d_2 + K_2 d_1)}{2(K_1 + K_2)}$
 (c) $\frac{K_1 d_1 + K_2 d_2}{d_1 + d_2}$ (d) $\frac{K_1 + K_2}{d_1 + d_2}$

29. Calculate I for the given circuit diagram.

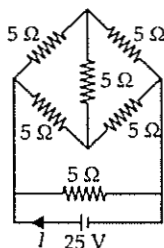

- (a) 10 A (b) 5 A (c) 2.5 A (d) 20 A
30. A solid cylinder, a circular disc, a solid sphere and a hollow cylinder of the same radius are placed on an inclined plane. Which of the following will have maximum acceleration at the bottom of the plane?
- (a) Circular disc. (b) Solid cylinder.
(c) Solid sphere. (d) Hollow cylinder.
31. Calculate the heat emitted by a bulb of 100 W in 1 min.
- (a) 100 J (b) 1000 J
(c) 600 J (d) 6000 J
32. Degree of freedom for polyatomic gas
- (a) ≥ 4 (b) ≥ 5 (c) ≥ 6 (d) ≥ 7
33. A particle moving about its equilibrium position with equation $y = -ax - bt$. Interpret the condition
- (a) It will always perform the SHM.
(b) It can never perform the SHM.
(c) It can perform SHM only when $t \geq \frac{bx}{a}$.
(d) It can perform SHM only when $t \leq \frac{bx}{a}$.
34. Conversion of water to steam is accompanied by which process?
- (a) Adiabatic. (b) Isothermal.
(c) Isochoric. (d) Cyclic.
35. An ideal gas is taken through the cycle $A \rightarrow B \rightarrow C \rightarrow A$, as shown in figure. If the net heat supplied to the gas in the cycle is 5 J the work done by the gas in the process $A \rightarrow B$ is

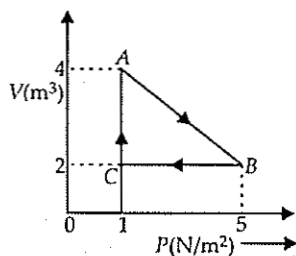

- (a) 2 J (b) 3 J (c) 4 J (d) 5 J
36. What is the slope for an isothermal process?
- (a) $\frac{P}{V}$ (b) $-\frac{P}{V}$ (c) Zero (d) ∞
37. The frequency order for X-rays (A), γ -rays (B), UV rays (C) is
- (a) $B > A > C$ (b) $A > B > C$
(c) $C > B > A$ (d) $A > C > B$
38. For a common-emitter transistor, input current is $5 \mu\text{A}$, $\beta = 100$ circuit is operated at load resistance of $10 \text{ k}\Omega$, then voltage across collector emitter will be
- (a) 5 V (b) 10 V (c) 12.5 V (d) 7.5 V
39. Find the voltage drop across a capacitor connected with a resistance and a battery of 60 V in series after a long time.
- (a) 0 V (b) 60 V (c) 30 V (d) 38 V
40. The nucleus ${}^m_n X$ emits one α particle and 2β -particles. The resulting nucleus is
- (a) ${}^{m-4}_{n-2} Y$ (b) ${}^{m-6}_{n-4} Z$
(c) ${}^{m-6}_{n} Z$ (d) ${}^{m-4}_{n} X$

Directions : In the following questions (41-60), a statement of assertion (A) is followed by a statement of reason (R). Mark the correct choice as :

- (a) If both assertion and reason are true and reason is the correct explanation of assertion.
(b) If both assertion and reason are true but reason is not the correct explanation of assertion.
(c) If assertion is true but reason is false.
(d) If both assertion and reason are false.
41. Assertion : Maximum air flow due to convection does not occur at the north pole but it occurs at 30°N .
Reason : There is maximum temperature difference between equator and 30°N
42. Assertion : A thick lens shows more chromatic aberration.
Reason : Thick lens behave as many thin lenses.
43. Assertion : Surface energy of an oil drop is same whether placed on glass or water surface.
Reason : Surface energy is dependent only on the properties of oil.

44. **Assertion** : Magnetic force is always perpendicular to the magnetic field.
Reason : Electric force is along the direction of electric field.
45. **Assertion** : Animate object can accelerate in the absence of external force.
Reason : Newton's second law is not applicable on animate object.
46. **Assertion** : A planar circular loop of area A and carrying current I is equivalent to magnetic dipole of dipole moment $M = IA$.
Reason : At large distances, magnetic field of circular loop and magnetic dipole is same.
47. **Assertion** : In elastic collision, kinetic energy is conserved.
Reason : Energy is always conserved.
48. **Assertion** : Bohr's atomic model cannot be used to explain multiple electron species.
Reason : It does not take inter-electronic interactions in account.
49. **Assertion** : The focal length of objective lens in telescope is much more than that of eye piece.
Reason : Telescope has high resolving power due to large focal length.
50. **Assertion** : Total energy of electron in an hydrogen atom is negative.
Reason : It is bounded to the nucleus.
51. **Assertion** : Vibrational energy of diatomic molecule corresponding to each degree of freedom is $k_B T$.
Reason : For every molecule, vibrational degree of freedom is 2.
52. **Assertion** : A superconductor is a perfect diamagnetic substance.
Reason : A superconductor is a perfect conductor.
53. **Assertion** : An electrostatic field line never form closed loop.
Reason : Electrostatic field is a conservative field.
54. **Assertion** : A charged particle can be accelerated in a cyclotron by the alternate distribution of the field.
Reason : Energy of charged particle is increased by the field applied.
55. **Assertion** : At rest, radium is decayed into Radon and an α -particle. They both moves back to back of each other.
Reason : Splitting of radioactive particle is based on conservation of linear momentum.
56. **Assertion** : In electromagnetic waves electric field and magnetic field lines are perpendicular to each other.
Reason : Electric field and magnetic field are self sustaining.
57. **Assertion** : Gauss's law shows diversion when inverse square law is not obeyed.
Reason : Gauss's law is a consequence of conservation of charges.
58. **Assertion** : More energy is released in fusion than fission.
Reason : More number of nucleons take part in fission.
59. **Assertion** : γ -radiation emission occurs after α and β decay.
Reason : Energy levels occur in nucleus.
60. **Assertion** : Turbulence is always dissipative.
Reason : High reynold number promotes turbulence.

CHEMISTRY

61. Threshold frequency of a metal is $5 \times 10^{13} \text{ s}^{-1}$ upon which $1 \times 10^{14} \text{ s}^{-1}$ frequency light is focused. Then the maximum kinetic energy of emitted electron is
 (a) 3.3×10^{-21} (b) 3.3×10^{-20}
 (c) 6.6×10^{-21} (d) 6.6×10^{-20}
62. Which is the major product formed when $\text{C}_6\text{H}_5\text{CONHC}_6\text{H}_5$ undergoes nitration?

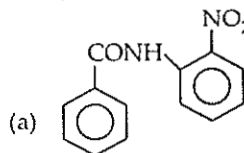

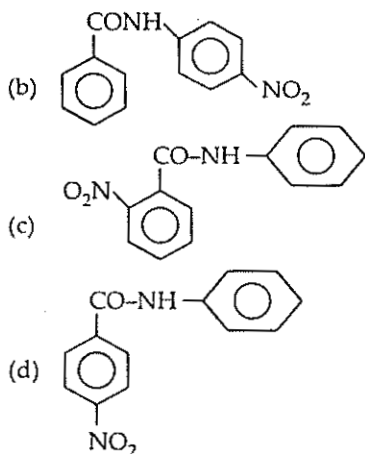

63. How many P=O bond present in $(\text{HPO}_3)_3$?
 (a) 0 (b) 3 (c) 6 (d) 9

64. At equilibrium which is correct?
 (a) $\Delta G = 0$ (b) $\Delta S = 0$
 (c) $\Delta H = 0$ (d) $\Delta G^\circ = 0$

65. If phthalic acid is treated with NH_3 and then it is first heated weakly then strongly, the final product formed is

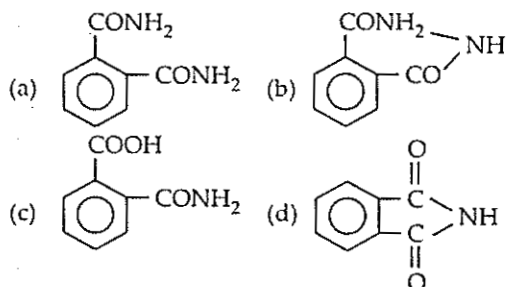

66. In bcc structure contribution of corner and central atom is

(a) $\frac{1}{8}, 1$ (b) $\frac{1}{4}, \frac{1}{8}$ (c) $\frac{1}{8}, \frac{1}{2}$ (d) $1, \frac{1}{2}$

67. Arrange the following gases in order of their critical temperature.

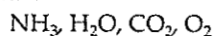

(a) $\text{NH}_3 > \text{H}_2\text{O} > \text{CO}_2 > \text{O}_2$
 (b) $\text{O}_2 > \text{CO}_2 > \text{H}_2\text{O} > \text{NH}_3$
 (c) $\text{H}_2\text{O} > \text{NH}_3 > \text{CO}_2 > \text{O}_2$
 (d) $\text{CO}_2 > \text{O}_2 > \text{H}_2\text{O} > \text{NH}_3$

68. Bond dissociation energy of CH_4 is 360 kJ/mol and C_2H_6 is 620 kJ/mol. Then bond dissociation energy of C—C bond is

(a) 170 kJ/mol (b) 50 kJ/mol
 (c) 80 kJ/mol (d) 220 kJ/mol

69. For silicon which is not correct?

(a) It is a type of silicate.
 (b) It is thermally unstable.
 (c) It is hydrophilic.
 (d) Repeating unit is R_2SiO .

70. In Bohr's orbit, $\frac{nh}{2\pi}$ indicates

(a) Momentum (b) Kinetic energy
 (c) Potential energy (d) Angular momentum

71. Which is not stable under ambient condition?

(a) $\text{TiO}_2, \text{Ti}^{+4}$ (b) VO, V^{+4}
 (c) $\text{VO}_2, \text{V}^{+5}$ (d) $\text{Cu}_2\text{O}, \text{Cu}^{+2}$

72. For a reaction, $r = k(\text{CH}_3\text{COCH}_3)^{3/2}$ then unit of rate of reaction and rate constant respectively is

(a) $\text{mol L}^{-1} \text{s}^{-1}, \text{mol}^{-1/2} \text{L}^{1/2} \text{s}^{-1}$
 (b) $\text{mol}^{-1} \text{L}^{-1} \text{s}^{-1}, \text{mol}^{-1/2} \text{L}^{-1/2} \text{s}^{-1}$
 (c) $\text{mol L}^{-1} \text{s}^{-1}, \text{mol}^{1/2} \text{L}^{1/2} \text{s}^{-1}$
 (d) $\text{mol L s}, \text{mol}^{1/2} \text{L}^{1/2} \text{s}$

73. Which of the following is the correct statement for PH_3 ?

(a) It is less poisonous than NH_3 .
 (b) It is less basic than NH_3 .
 (c) Electronegativity of $\text{PH}_3 > \text{NH}_3$.
 (d) It does not show reducing properties.

74. If Si is doped with B,

(a) *n*-type semiconductor is formed
 (b) *p*-type semiconductor is formed
 (c) insulator is formed
 (d) polymer is formed.

75. Which has the highest pH?

(a) CH_3COOK (b) Na_2CO_3
 (c) NH_4Cl (d) NaNO_3

76. Living in the atmosphere of CO is dangerous, because it

(a) combines with O_2 present inside to form CO_2
 (b) reduces organic matter of tissues
 (c) combines with haemoglobin and makes it incapable to absorb oxygen
 (d) dries up the blood.

77. In a set of reactions, acetic acid yielded a product S.

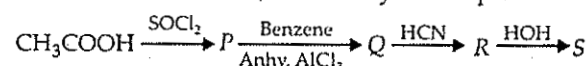

The structure of S would be

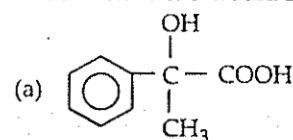

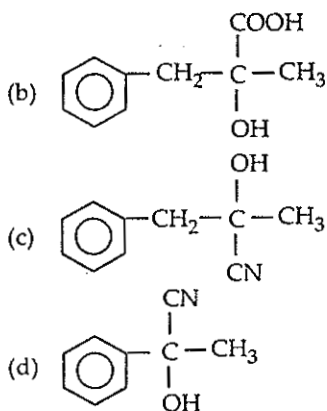

78. Which of the following is a chiral compound?
 (a) Hexane (b) *n*-Butane
 (c) Methane
 (d) 2,3,4-Trimethylhexane.
79. For $Zn^{2+} | Zn, E^\circ = -0.76 V$ then EMF of the cell $Zn/Zn^{2+} (1M) | 2H^+ (1M) | H_2 (1 atm)$ will be
 (a) $-0.76 V$ (b) $0.76 V$
 (c) $0.38 V$ (d) $-0.38 V$
80. $\frac{K_p}{K_c}$ for following reaction will be
 $CO_{(g)} + \frac{1}{2} O_{2(g)} \rightarrow CO_{2(g)}$
 (a) RT (b) $\frac{1}{RT}$ (c) $\frac{1}{\sqrt{RT}}$ (d) $\frac{RT}{2}$
81. If $t_{1/2}$ vs $\frac{1}{a^2}$ is a straight line graph then determine the order of reaction.
 (a) Zero order (b) First order
 (c) Second order (d) Third order
82. CsCl has bcc arrangement. Its unit cell edge length is 400 pm. Its inter-ionic distance is
 (a) 400 pm (b) 800 pm
 (c) $\sqrt{3} \times 100$ pm (d) $\frac{\sqrt{3}}{2} \times 400$ pm
83. A colloidal solution is kept in dark and is illuminated by a beam of light then brightness appears at the right angle of direction of light. This effect is called
 (a) Tyndall effect (b) Brownian effect
 (c) Hardy-Schulze effect
 (d) None of these
84. MnO_3 in an acidic medium dissociates into
 (a) MnO_2 and MnO_4^- (b) MnO and MnO_4^-
 (c) MnO_2 and MnO (d) MnO_2 and MnO_3

85. Magnetic moment of Cr^{2+} is nearest to
 (a) Fe^{2+} (b) Mn^{2+} (c) Co^{2+} (d) Ni^{2+}
86. Which of the following compounds are optically active?
- (1)
- (2)
- (3)
- (4)
- (a) 1 and 2 (b) 2 and 3
 (c) 3 and 4 (d) 1 and 4
87. Which will not form precipitation after addition of $(NH_4)_2CO_3$ in presence of NH_4Cl ?
 (a) Mg (b) Ba (c) Sn (d) Sr
88. Difference in atomic radius is maximum for
 (a) Rb-Cs (b) K-Rb
 (c) Na-K (d) Li-Na
89. The dipole moment is minimum in
 (a) NH_3 (b) NF_3 (c) SO_2 (d) BF_3
90. Number of isomers of C_5H_6
 (a) 2 (b) 3 (c) 4 (d) 5
91. At 60° and 1 atm, N_2O_4 is 50% dissociated into NO_2 then K_p is
 (a) 1.33 atm (b) 2 atm
 (c) 2.67 atm (d) 3 atm
92. pK_a increases in benzoic acid when substituent "x" is bonded at *para*-position, then "x" is
 (a) $-COOH$ (b) $-NO_2$
 (c) $-CN$ (d) $-OCH_3$
93. $S_2O_8^{2-}$ have
 (a) S-S bond (b) S-O bridge
 (c) O-O bridge
 (d) All S-O bond lengths are same.
94. N-N bond length is minimum in
 (a) N_2O (b) N_2O_3
 (c) N_2O_4 (d) N_2O_5
95. Which is correct example of condensation polymer?
 (a) Nylon, Buna-S (b) Teflon, Buna-N
 (c) Nylon 6,6, Dacron (d) Neoprene, Buna-S

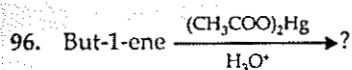

The product in the above reaction is

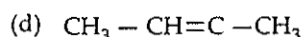
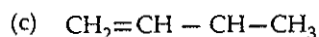
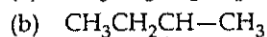
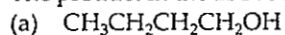

P will be

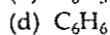
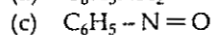
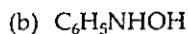
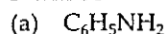

98. Which is correct order of solubility in water?

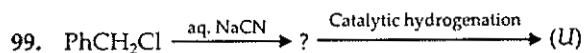
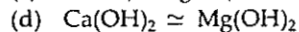
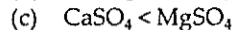
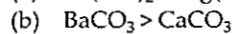
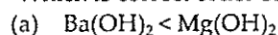

The final product (U) is :

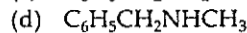
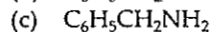
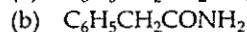
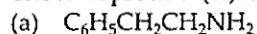

100. An aromatic compound $\text{C}_7\text{H}_6\text{Cl}_2$ (A), gives AgCl on boiling with alcoholic AgNO_2 solution and yields $\text{C}_7\text{H}_7\text{OCl}$ on treatment with sodium hydroxide. (A) on oxidation gives monochlorobenzoic acid. The compound (A) is:

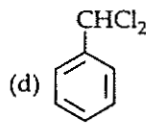
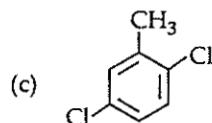
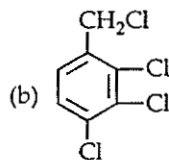
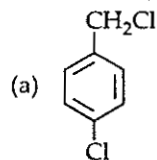

Directions : In the following questions (101-120), a statement of assertion (A) is followed by a statement of reason (R). Mark the correct choice as :

(a) If both assertion and reason are true and reason is the correct explanation of assertion

(b) If both assertion and reason are true but reason is not the correct explanation of assertion

(c) If assertion is true but reason is false

(d) If both assertion and reason are false.

101. Assertion : Rate of reaction doubles when concentration of reactant is doubled if it is a first order reaction.

Reason : Rate constant also doubles.

102. Assertion : Sodium acetate on Kolbe's electrolysis gives methane.

Reason : Methyl free radical is formed at cathode.

103. Assertion : H_3PO_2 has strong reducing property but H_3PO_4 does not.

Reason : P-OH bond present in H_3PO_4 .

104. Assertion : Diamond and graphite do not have the same crystal structure.

Reason : Diamond is crystalline while graphite is amorphous.

105. Assertion : Bohr model fails in case of multi-electron species.

Reason : It does not mention electron-electron interactions.

106. Assertion : 1,2-dichloroethane is optically active.

Reason : Meso compound is optically active.

107. Assertion : ClF_3 has T-shape structure.

Reason : It has two lone pairs arranged at 180° angle.

108. Assertion : O_2 is paramagnetic.

Reason : It has one unpaired electron.

109. Assertion : Phenol is more reactive than benzene towards electrophilic substitution reaction.

Reason : In the case of phenol, the intermediate carbocation is more resonance stabilised.

110. Assertion : H_2Se is less acidic than H_2S .

Reason : S is less electronegative than Se.

111. Assertion : Fluorine is a stronger oxidizing agent than iodine.

- Reason** : Fluorine has greater electronegativity than iodine.
112. **Assertion** : Ce^{4+} is used as an oxidising agent in volumetric analysis.
- Reason** : Ce^{4+} has the tendency of attaining +3 oxidation state.
113. **Assertion** : The spectrum of He^+ is expected to be similar to that of hydrogen.
- Reason** : He^+ is also one electron system.
114. **Assertion** : Cl_2 gas bleaches the articles permanently.
- Reason** : Cl_2 is a strong reducing agent.
115. **Assertion** : $\text{La}(\text{OH})_3$ is more basic than $\text{Lu}(\text{OH})_3$.
- Reason** : Size of Lu^{3+} increases and shows more covalent character.
116. **Assertion** : F^- ion is a weak ligand and forms outer orbital complex.
- Reason** : F^- ion cannot force the electrons of d_z^2 and $d_x^2 - y^2$ orbitals of the inner shell to occupy d_{xy} , d_{yz} and d_{zx} orbitals of the same shell.
117. **Assertion** : $[\text{Fe}(\text{H}_2\text{O})_5\text{NO}]\text{SO}_4$ is paramagnetic.
- Reason** : The Fe in $[\text{Fe}(\text{H}_2\text{O})_5\text{NO}]\text{SO}_4$ has three unpaired electrons.
118. **Assertion** : The solubility of a gas in a liquid increases with increase of pressure.
- Reason** : The solubility of a gas in a liquid is directly proportional to the pressure of the gas.
119. **Assertion** : $\text{HC}\equiv\text{C}^-$ is more stable than $\text{H}_2\text{C}=\text{CH}^-$.
- Reason** : $\text{HC}\equiv\text{C}^-$ has more s-character than $\text{H}_2\text{C}=\text{CH}^-$.
120. **Assertion** : In a pressure cooker, the water is brought to boil. The cooker is then removed from the stove. Now on removing the lid of pressure cooker, the water starts boiling again.
- Reason** : The impurities in water bring down its boiling point.

BIOLOGY

121. Which of the following is correct regarding respiration in adult frog?
- In water- Skin, gills
 - On land - Skin, buccal cavity
 - In water- Skin, buccal cavity
 - On land- Skin, lungs, gills.
122. Which of the following is correctly matched?
- Monstera*- Fibrous root
 - Dahlia*- Fasciculated root
 - Azadirachta* - Adventitious root
 - Basil- Prop roots
123. The 'cells of Rauber' are
- secretory cells of endometrium in uterus
 - inner cell mass of blastocoele
 - outer cells of trophoblast in contact with uterine wall
 - cells of trophoblast, in contact with inner cell mass of blastocyst.

124.

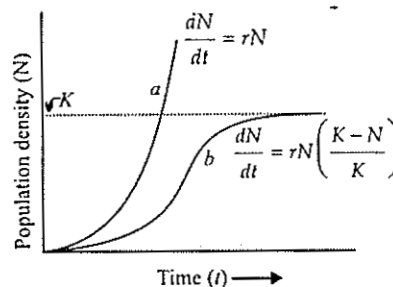

Which is correctly labelled with respect to the given diagram?

- B : Logistic curve
 - C : Carrying capacity
 - C : Exponential curve
 - A : Carrying capacity
125. Deuteromycetes are known as fungi imperfecti because
- their zygote undergoes meroblastic and holoblastic cleavage
 - only asexual stages are known
 - they have aseptate mycelium
 - they are autotrophic.
126. Abscisic acid is known as the stress hormone because it
- breaks seed dormancy
 - induces flowering
 - promotes leaf fall
 - promotes closure of stomata.

127. Choose the correct statement.
- hPL plays a major role in parturition.
 - Foetus shows movements first time in the 7th month of pregnancy.
 - Signal for parturition comes from fully developed foetus and placenta.
 - Embryo's heart is formed by the 2nd month of pregnancy.
128. One of the world's most poisonous fish toxins is released by
- clown fish
 - sword fish
 - eel fish
 - puffer fish.
129. Na⁺/K⁺ pump is associated with
- passive transport
 - active transport
 - osmosis
 - imbibition.
130. Which one has the largest species variety in India?
- Wheat
 - Maize
 - Rice
 - Potato.
131. Photorespiration shows formation of
- sugar but not ATP
 - ATP but not sugar
 - both ATP and sugar
 - neither ATP nor sugar.
132. The microscope usually used for seeing living cells or tissues is
- compound microscope
 - electron microscope
 - phase contrast microscope
 - light microscope.

133.

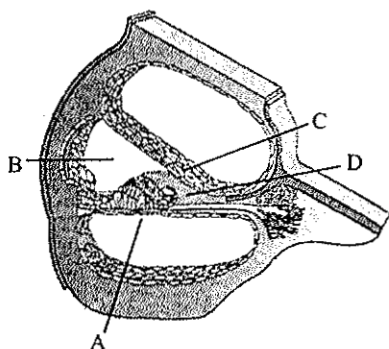

Which of the following is correctly labelled?

- A : Reissner's membrane
- B : Scala vestibuli
- C : Basilar membrane

(d) D : Tectorial membrane.

134. In aerobic respiration, total number of ATP molecules formed from 1 glucose molecule is
- 28
 - 32
 - 36
 - 30.
135. Which of the following cartoon characters does not share its name with that of a gene?
- Tintin
 - Popeye
 - Asterix
 - Obelix
136. Apiculture is associated with which of the following groups of plants?
- Grapes, maize, potato
 - Sugarcane, paddy, banana
 - Guava, sunflower, strawberry
 - Pineapple, sugarcane, strawberry.

137.

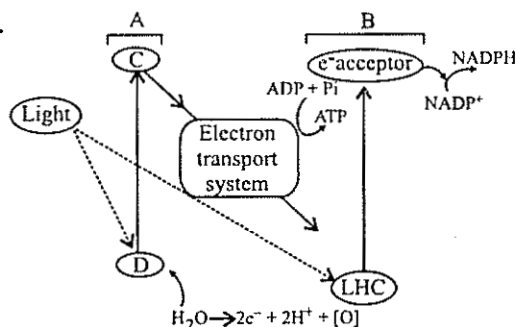

Which of the following is correctly labelled for the given figure?

- A : PS II ; B : PS I ; C : e⁻ acceptor ; D : LHC
 - A : LHC ; B : e⁻ acceptor ; C : PS I ; D : PS II
 - A : PS I ; B : PS II ; C : e⁻ acceptor ; D : LHC
 - A : e⁻ acceptor ; B : LHC ; C : PS II ; D : PS I
138. During muscular contraction, which of the following events occur?
- H-zone disappears
 - A band widens
 - I band reduces in width
 - Width of A band is unaffected
 - M line and Z line come closer.
- (i), (iii), (iv) and (v)
 - (i), (ii) and (v)
 - (ii), (iv) and (v)
 - (i), (ii) and (iii).

139. The release of chemical messenger from synaptic vesicles is under the influence of these ion(s).

- Cl⁻
- Fe²⁺ and S²⁺
- Ca²⁺
- Mg²⁺ and Sr²⁺





140. Cattle ranches are known to cause acute green house effect. This is due to
 (a) mechanized milking practices
 (b) methanogenic bacteria in rumen
 (c) decomposition of left over fodder
 (d) decomposition of organic remains in faeces.

141. Kranz anatomy is usually associated with
 (a) C_3 plants
 (b) C_4 plants
 (c) CAM plants
 (d) C_3 - C_4 intermediate plants.

142. Microtubule depolymerizing drug such as colchicine is expected to
 (a) inhibit spindle formation during mitosis
 (b) inhibit cytokinesis
 (c) allow mitosis beyond metaphase
 (d) induce formation of multiple contractile rings.

143. Catecholamine in a normal person induces
 (a) intense salivation
 (b) alertness
 (c) decrease in heart beat
 (d) excessive urination.

144. Select the option having all the correct characteristics.

	Structure	Percentage	Function
(a)		0.3 - 0.5	Phagocytic
(b)		0.5 - 1.0	Secrete histamine and serotonin
(c)		30 - 40	Defence against parasites
(d)		30 - 40	Allergic reactions

145. Plants with inferior ovary usually bear
 (a) pseudocarps (b) berries
 (c) aggregate fruits (d) seedless fruits.

146. Oxygen binding to haemoglobin in blood is
 (a) directly proportional to the concentration of CO_2 in the medium
 (b) inversely proportional to the concentration of CO_2 in the medium
 (c) directly proportional to the concentration of CO in the medium

- (d) independent of the concentration of CO in the medium.

147. Leghaemoglobin is produced in response to
 (a) respiration (b) photosynthesis
 (c) fatty acid synthesis (d) N_2 fixation.

148. The extinct human ancestor, who ate only fruits and hunted with stone weapons was
 (a) *Ramapithecus* (b) *Australopithecus*
 (c) *Dryopithecus* (d) *Homo erectus*.

149. What is common between earthworm and *Periplaneta*?
 (a) Both have red coloured blood
 (b) Both possess anal styles
 (c) Both have malpighian tubules
 (d) Both have segmented body.

150. In a normal adult, ascending order of concentration of following molecules is
 (a) $K > Na > Fe > Cu$ (b) $Na > K > Cu > Fe$
 (c) $Fe > Na > K > Cu$ (d) $Na > Fe > K > Cu$

151. Which of the following statements is incorrect about G_0 phase?

- (a) Mitosis occurs after G_0 phase.
 (b) Biocatalysts can be used to exit G_0 phase.
 (c) Cell volume keeps on increasing during this phase.
 (d) Cell metabolism occurs continuously in G_0 phase.

152. Beads on string like structures of A are seen in B, which further condense to form chromosomes in C stage of cell division.

	A	B	C
(a)	Chromonema	Chromatin	Metaphase
(b)	Chromatin	Chromatid	Metaphase
(c)	Chromonema	Chromosome	Anaphase
(d)	Chromonema	Chromatid	Anaphase.

153. RNA interference is essential for the
 (a) cell proliferation (b) cell defence
 (c) cell differentiation (d) micropropagation.

154. Select the option having all correctly matched pairs.

A. Alkaloids	(i) Carotenoid; Anthocyanin
B. Pigments	(ii) Vinblastin; curcumin
C. Drugs	(iii) Morphine; Codeine
(a)	A-i; B-ii; C-iii (b) A-ii; B-iii; C-i
(c)	A-iii; B-i; C-ii (d) A-i; B-iii; C-ii.

155. Dust, oolong and brick are varieties of
 (a) coffee (b) pepper
 (c) tea (d) lavang.
156. Ventricular diastole occurs due to a/an
 (a) organ system (b) cell organelle
 (c) tissue (d) organ.

157.

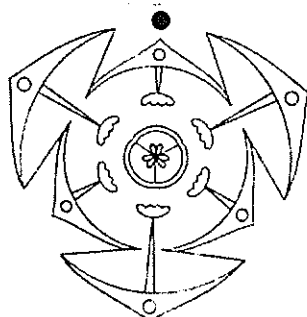

Plants having the above given floral diagram are

- (a) leguminous
 (b) dicots
 (c) medicinal and perennial
 (d) having pinnately compound leaves.
158. Select the correct statement.
 (a) Particulate matter of size 10 μm can create severe damage to the lungs.
 (b) Particulate matter of size greater than 2.5 μm can get trapped in lungs and cause problems.
 (c) Particulate matter of size less than 2.5 μm penetrate deep into lungs.
 (d) None of the above.
159. Pebrine in silkworms is caused by
 (a) *Dugesia* (b) *Monocystis*
 (c) *Nosema* (d) *Plasmodium*.
160. Which of the following is a homopolysaccharide?
 (a) Heparin (b) Inulin
 (c) Pectin (d) Hyaluronic acid.

Direction : In the following questions (161-180), a statement of assertion (A) is followed by a statement of reason (R). Mark the correct choice as :

- (a) If both assertion and reason are true and reason is the correct explanation of assertion
 (b) If both assertion and reason are true but reason is not the correct explanation of assertion
 (c) If assertion is true but reason is false
 (d) If both assertion and reason are false.

161. **Assertion :** There are 34 biodiversity hotspots in the world.

Reason : High level of species richness is a criteria for selection of a biodiversity hotspot.

162. **Assertion :** Inbreeding increases homozygosity, thus exposes harmful recessive genes, which are eliminated by selection.

Reason : Continued inbreeding reduces fertility and productivity.

163. **Assertion :** Some marine animals find it difficult to live in fresh water and *vice versa*.

Reason : Some animals can tolerate a narrow salinity range, while others can tolerate a wide salinity range.

164. **Assertion :** Myelin sheath insulates the nerve fibre and prevents its depolarisation.

Reason : Nerve impulses are conducted more rapidly in non - myelinated nerve fibres than in myelinated ones.

165. **Assertion :** Frog can change its colour, according to its surroundings.

Reason : It is a way of mimicry to capture preys.

166. **Assertion :** Less iodine intake causes goitre.

Reason : Less iodine in body decreases thyroxine secretion.

167. **Assertion :** $\text{Hb}^s \text{Hb}^s$ denotes the homozygous condition for sickle-cell anaemia.

Reason : It occurs due to substitution of glutamic acid by valine at the 6th position of β -chain of Hb.

168. **Assertion :** Excess Mn in soil, can adversely decrease Mg, Fe and Cu concentrations in the soil.

Reason : Mn increases rate of photosynthesis, thereby increasing absorption of Mg, Fe and Ca from soil.

169. **Assertion :** A middle aged woman is reported to have small breasts and undersized uterus.

Reason : Her genotypic analysis shows XO condition of allosomes.

170. Assertion : In proximal convoluted tubule glomerular filtrate becomes hypertonic to blood plasma.

Reason : HCO_3^- is absorbed only in the proximal convoluted tubule.

171. Assertion : Complexity of classification increases from kingdom to species.

Reason : Common characters increase from kingdom to species.

172. Assertion : In a terrestrial ecosystem, detritus food chain is the major conduit for energy flow.

Reason : Solar energy is the direct source for energy supply in a detritus food chain.

173. Assertion : Filarial worm is transmitted to humans by *Culex* mosquito.

Reason : *Culex* prefers to breed in fresh water.

174. Assertion : AIDS is caused by the HIV, a retrovirus.

Reason : Retroviruses have RNA genome.

175. Assertion : A male is found to be lacking facial hair and pubic hair.

Reason : It is a case of hyposecretion of testosterone from Leydig's cells of testes.

176. Assertion : Extra oxygen consumption in human body is known as oxygen debt.

Reason : The extra oxygen is required by the body to oxidise the accumulated lactic acid produced during strenuous exercise.

177. Assertion : Emulsification is necessary for the digestion of fats.

Reason : After fats are emulsified, the action of enzyme amylase gets significantly increased.

178. Assertion : In jaundice, the skin and mucous membranes assume a yellowish hue.

Reason : Yellow pigment bilirubin imparts pale yellow colour to blood plasma.

179. Assertion : No taste sensation is evoked when drop of distilled water is put on human tongue.

Reason : Man does not possess taste buds for tasting water.

180. Assertion : Oxytocin is also known as Anti-diuretic hormone (ADH).

Reason : Oxytocin can cause an increase in the renal reabsorption of water.

GENERAL KNOWLEDGE

181. The birth place of philosopher Ramanuja is the death place of which Prime Minister?

- (a) Indira Gandhi (b) Rajiv Gandhi
(c) Jawaharlal Nehru (d) Morarji Desai.

182. Which breed of dog does not bark?

- (a) Doberman (b) Basenji
(c) German Shepherd
(d) Dalmatian.

183. Which author of Indian origin was born in the Caribbean Nation of Trinidad and Tobago?

- (a) Salman Rushdie (b) V.S. Naipaul
(c) Shashi Tharoor (d) Nirad C. Chaudhuri.

184. Tezpur in north-east is famous for

- (a) hottest chilli in the world
(b) sweetest apple
(c) largest producer of gold
(d) largest producer of coal

185. Belt and Jacket, Catch-hold and loose styles are the basic types of which sport?

- (a) Boxing (b) Wrestling
(c) Kho-Kho (d) Kabaddi.

186. Kashmiri stag is also known as

- (a) Hangul (b) Nilgai
(c) Sambhar (d) Chital.

187. Who was the first Indian Prime Minister to lose an election?

- (a) Lal Bahadur Shastri
(b) V.P. Singh
(c) Morarji Desai (d) Indira Gandhi.

188. The city of Mysore has derived its name from the sanskrit word, for which of these?

- (a) Beautiful town (b) Buffalo town
(c) Great town (d) Golden town.

189. Which of the following persons founded Indian National Orchestra?

- (a) Zubin Mehta (b) Shankar Mahadevan
(c) A.R. Rehman (d) Ravi Shankar.
190. Which is the second highest civilian award in India?
(a) Bharat Ratna (b) Padma Vibhushan
(c) Padma Bhushan (d) Padma Shri.
191. Surface of which gemstone is called orient?
(a) Emerald (b) Emethyst
(c) Pearl (d) Diamond.
192. Which of the following states is the highest producer of soyabean in India?
(a) Uttar Pradesh (b) Andhra Pradesh
(c) Rajasthan (d) Madhya Pradesh.
193. Who captained India in woman cricket world cup 2000?
(a) Anju Jain (b) Neetu David
(c) Shantha Rangaswami
(d) Poornima Rao.
194. Which Union Territory has its name on the basis of a temple in the village Manimajra?
(a) Chandigarh (b) Lakshdweep
(c) Pondicherry (d) Daman and Diu.
195. In tricolour flag of India, saffron colour is a symbol of
(a) unity (b) sacrifice
(c) peace (d) prosperity.
196. Which of the following languages is not based on Devanagari script?
(a) Hindi (b) Sanskrit
(c) Nepali (d) Urdu.
197. Which one of the following is a military alliance?
(a) ASEAN (b) SAARC
(c) NATO (d) NAFTA.
198. 'Fanning and Dust', these terms are associated with
(a) tea (b) coffee
(c) soup (d) cold drink.
199. Which one of the following footballers is awarded Arjuna Award 2011?
(a) Sunil Chhetri (b) Baichung Bhutia
(c) Bruno Coutinho (d) I.M. Vijayan.
200. 'Cix's Bazar' is situated in
(a) Pakistan (b) Sri Lanka
(c) Bangladesh (d) Indonesia.

SOLUTIONS

PHYSICS

1. (b) : In an unbiased PN junction diode current flow due to minority charge carriers (electron in the P-region and holes in the N-region).

2. (c) : If $\frac{dI}{dt}$ is the rate of change of current through inductor L of any instant, then induced emf in the inductor of the same instant is

$$= \left(-L \frac{dI}{dt} \right)$$

To maintain the flow of current in the circuit applied voltage must be equal and opposite to the induced voltage.

$$\therefore V = - \left(-L \frac{dI}{dt} \right)$$

Given, $V = V_0 \sin \omega t$...(i)

$$\therefore V_0 \sin \omega t = \frac{L dI}{dt}$$

$$\frac{dI}{dt} = \frac{V_0}{L} \sin \omega t$$

or $I = \frac{-V_0 \cos \omega t}{L \omega}$...(ii)

Instantaneous power,

$$\therefore P = VI$$

$$= (V_0 \sin \omega t) \left(-\frac{V_0 \cos \omega t}{L \omega} \right) \quad (\text{Using (i) \& (ii)})$$

$$= \frac{-V_0^2 \sin 2\omega t}{2L \omega}$$

3. (c) : The resultant intensity is given by

$$I_R = I_1 + I_2 + 2\sqrt{I_1 I_2} \cos \phi$$

For constructive interference, $\cos \phi = 1$

$$\therefore I_R = I_1 + I_2 + 2\sqrt{I_1 I_2}$$

or $I_R = 4I$ (Given $I_1 = I_2 = I$)

4. (b) : Let L is the distance between a real object and its real image formed by a convex lens, then as

$$L = (|u| + |v|) \\ = (\sqrt{u} - \sqrt{v})^2 + 2\sqrt{uv} \quad \dots(i)$$

L will be minimum, when

$$(\sqrt{u} - \sqrt{v})^2 = 0$$

i.e., $u = v$

Putting, $u = -u$ and $v = +u$ in lens formula,

$$\frac{1}{v} - \frac{1}{u} = \frac{1}{F}$$

$$\frac{1}{u} - \frac{1}{-u} = \frac{1}{F}$$

$$u = 2F$$

$$\therefore (L)_{\min} = 2\sqrt{2F \times 2F} = 4F \quad (\text{Using (i)})$$

5. (a) : The fringe width is given by

$$\beta = \frac{\lambda D}{d}$$

Here D is the separation between screen and slits and d is the separation between slits.

6. (c) : Here, $T_{1/2} = 8$ years
 $t = 32$ years

Using, $N = N_0 \left(\frac{1}{2} \right)^{\frac{t}{T_{1/2}}}$

$$\left(\frac{N}{N_0} \right) = \left(\frac{1}{2} \right)^{\frac{32}{8}}$$

$$= \left(\frac{1}{2} \right)^4$$

$$\left(\frac{N}{N_0} \right) = \frac{1}{16}$$

7. (c) : In the circuit, the zener diode is used as power regular therefore,

$$P = VI \\ = 12 \times 0.05 = 0.6 \text{ W.}$$

8. (c) : The relation between kinetic energy, threshold frequency and frequency of photon is given as

$$\frac{1}{2} m v^2 = (h\nu - h\nu_0) \\ = h(1 \times 10^{14} - 5 \times 10^{13}) \\ k = h(5 \times 10^{13}) \\ = 6.67 \times 10^{-34} \times 5 \times 10^{13} \\ = 3.3 \times 10^{-20} \text{ J.}$$

9. (a) : The phase angle

$$\theta = \tan^{-1} \left(\frac{X_C - X_L}{R} \right)$$

$$= \tan^{-1} \left(\frac{8-5}{4} \right)$$

$$\theta = \tan^{-1} \left(\frac{3}{4} \right)$$

Therefore, the current leads the voltage by

$$\tan^{-1} \left(\frac{3}{4} \right)$$

10. (a) : Here, $m = 100 \text{ g} = 10^{-1} \text{ kg}$, $l = 1 \text{ m}$, $I = 5 \text{ A}$
 For a wire balanced midway air by a magnetic field is
 $mg = IlB$.
 or $B = \frac{mg}{Il}$
 $= \frac{10^{-1} \times 10}{5 \times 1}$
 $B = 0.2 \text{ T}$.
11. (a) : Heat supplied to a system is in the form of energy.
 \therefore Dimensional formula is $[M L^2 T^{-2}]$.
12. (d) : The magnetic field at any point inside the toroid is zero.
13. (d)
14. (a)
15. (b) : Magnetic dipole moment of electron in an atom is given as
 $M = \frac{n e h}{4 \pi m} = n \mu_B$
 where, n = number of orbit
 μ_B = Bohr Magnetron
 For minimum dipole moment, $n = 1$
 $\therefore M = \frac{e h}{4 \pi m}$
16. (a)
17. (a) : Total energy of an electron in hydrogen atom above 0 eV leads to continuation of energy states.
18. (c) : Two parallel current carrying wires in the same direction attract each other whereas two parallel current carrying wires in the opposite direction repel each other.
19. (b) : Let a particle of mass m is thrown vertically upwards with velocity v . Let its velocity be v' at a height $3R$ from the surface of the earth.
 According to the conservation of energy,

$$\frac{1}{2} m v^2 - \frac{GMm}{R} = \frac{1}{2} m v'^2 - \frac{GMm}{(R+3R)}$$

$$v^2 - \frac{2GM}{R} = v'^2 - \frac{2GM}{4R}$$

$$v^2 - v'^2 = \frac{-2GM}{4R} + \frac{2GM}{R} = \frac{6GM}{4R}$$

$$v^2 = v'^2 + \frac{6GM}{4R}$$

$$v^2 = \sqrt{(11.2)^2 - \frac{3}{2} g R} \quad \left(\because g = \frac{GM}{R^2} \right)$$

$$= \sqrt{(11.2)^2 - \frac{3}{2} \times \frac{9.8 \times 6400}{1000}}$$

$$= \sqrt{(11.2)^2 - (94.08)}$$

$$= 5.6 \text{ km s}^{-1}$$

20. (d) : The Gamma decay due to instability of nucleus is excess energy of nucleus.
21. (c) : de broglie wavelength,
 $\lambda = \frac{h}{\sqrt{2mk}}$
 or $k = \frac{h^2}{2m\lambda^2}$
 $= \frac{(6.67 \times 10^{-34})^2}{2 \times 9.1 \times 10^{-31} \times (1 \times 10^{-9})^2} = 1.5 \text{ eV}$.
22. (c) : Terminal velocity
 $V_t \propto D^2$.
23. (a) : Electric field due to a long charged wire is given as
 $E = \frac{\lambda}{2\pi \epsilon_0 r}$
 where, λ = linear charge density.
 r = distance from the wire.
 $\therefore E \propto \frac{1}{r}$
24. (a) : Mass (m) = 2 kg; initial radius of the path (r_1) = 0.8 m; initial angular velocity (ω_1) = 44 rad/sec and final radius of the path (r_2) = 1 m.
 Moment of inertia, $I_1 = m r_1^2 = 2 \times (0.8)^2 = 1.28 \text{ kg m}^2$ and $I_2 = m r_2^2 = 2 \times (1)^2 = 2 \text{ kg m}^2$
 Therefore from the law of conservation of angular momentum $I_1 \omega_1 = I_2 \omega_2$
 or $\omega_2 = \frac{I_1 \times \omega_1}{I_2} = \frac{1.28 \times 44}{2}$
 $\omega_2 = 28.16 \text{ rad/sec}$

25. (b)

26. (a) : Since, $\vec{v} = v_0 \hat{i}$

$$\vec{E} = E_0 \hat{j}$$

The electron is moving in x-direction perpendicular to the electric field which is in y-direction.

Thus, the path of electron moving perpendicular to field will be a parabola.

27. (b) : Effective acceleration due to gravity due to rotation earth is given as

$$g' = g - R\omega^2 \cos^2 \phi$$

\therefore Change in acceleration, $dg = R\omega^2 \cos^2 \phi$

$\therefore dg \propto \cos^2 \phi$

28. (c) : Let t be the width and L be the length of each conductor.

$$\text{Effective thermal resistance, } R_p = \frac{R_1 R_2}{R_1 + R_2}$$

$$\therefore R = \frac{L}{kA}$$

where k = thermal conductivity

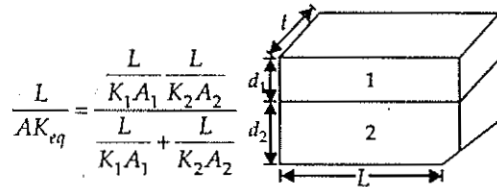

$$\frac{L}{AK_{eq}} = \frac{\frac{L}{k_1 A_1} + \frac{L}{k_2 A_2}}{\frac{L}{k_1 A_1} + \frac{L}{k_2 A_2}}$$

$$\Rightarrow \frac{1}{K_{eq}(A_1 + A_2)} = \frac{1}{K_2 A_2 + K_1 A_1}$$

$$\Rightarrow K_{eq} = \frac{K_1 A_1 + K_2 A_2}{A_1 A_2}$$

$$= \frac{K_1 d_1 t + K_2 d_2 t}{d_1 t + d_2 t} = \frac{K_1 d_1 + K_2 d_2}{d_1 + d_2}$$

29. (a) : It is a balanced Wheatstone bridge. Hence no current flows through resistance of arm BD and the resistance of arm BD is ineffective.

$$\therefore \frac{R_{AB}}{R_{BC}} = \frac{R_{AD}}{R_{DC}}$$

$$\Rightarrow \frac{5 \Omega}{5 \Omega} = \frac{5 \Omega}{5 \Omega}$$

Resistance of arm $ABC = 5 \Omega + 5 \Omega = 10 \Omega$

Resistance of arm $ADC = 5 \Omega + 5 \Omega = 10 \Omega$

The effective resistance between A and C is

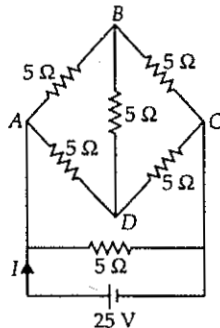

$$\frac{1}{R_{AC}} = \frac{1}{10} + \frac{1}{10} \text{ or } R_{AC} = 5 \Omega$$

Now the equivalent circuit becomes

\therefore The equivalent resistance of the circuit

$$\frac{1}{R} = \frac{1}{5} + \frac{1}{5} \text{ or } R = 2.5 \Omega$$

Current in the circuit,

$$I = \frac{V}{R} = \frac{25}{2.5} = 10 \text{ A}$$

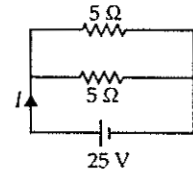
30. (c) : Let the inclination of the inclined plane be θ . Acceleration of a rolling body is given as

$$a = \frac{g \sin \theta}{(1 + K^2/R^2)}$$

Here, K is radius of gyration.

For circular disc

$$I = \frac{1}{2} MR^2 \therefore \frac{K^2}{R^2} = \frac{1}{2}$$

$$\therefore a = \frac{2}{3} g \sin \theta \quad \dots(i)$$

For solid cylinder

$$I = \frac{1}{2} MR^2 \therefore \frac{K^2}{R^2} = \frac{1}{2}$$

$$\therefore a = \frac{2}{3} g \sin \theta \quad \dots(ii)$$

For solid sphere

$$I = \frac{2}{5} MR^2 \therefore \frac{K^2}{R^2} = \frac{2}{5}$$

$$\therefore a = \frac{5}{7} g \sin \theta \quad \dots(iii)$$

For hollow cylinder

$$I = MR^2 \therefore \frac{K^2}{R^2} = 1$$

$$\therefore a = \frac{1}{2} g \sin \theta \quad \dots(iv)$$

Hence, from (i), (ii), (iii) and (iv) we conclude that the solid sphere will reach the bottom with maximum acceleration.

31. (d) : Here, $P = 100 \text{ W}$, $t = 10 \text{ min} = 60 \text{ s}$

Heat developed in time t

$$H = P \times t = (100 \text{ W})(60 \text{ s}) = 6000 \text{ J}$$

32. (c) : A polyatomic gas has 3 translational, 3 rotational degrees of freedom and a certain number (f) of vibrational modes. Hence, the degree of freedom for polyatomic gas is ≥ 6 .

33. (b)

34. (b)

35. (b) :

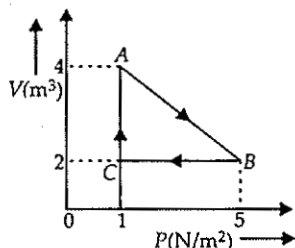

Process $B \rightarrow C$ occurs at constant volume

Hence, $W_{BC} = 0$

Process $C \rightarrow A$ occurs at constant process.

Hence the work done in the process is

$$W_{CA} = P\Delta V = (1)(V_A - V_C) = (1)(4 - 2) = 2 \text{ J}$$

For a cyclic process, $\Delta U = 0$

According to the first law of thermodynamics

$$\Delta Q = \Delta W + \Delta U$$

$$\Delta Q = \Delta W$$

$$= W_{AB} + W_{BC} + W_{CA}$$

$$5 = W_{AB} + 0 + 2 \text{ or } W_{AB} = 3 \text{ J}$$

36. (b) : For an isothermal process, the slope is

$$-\frac{P}{V}$$

37. (a) : The frequency order for given

electromagnetic waves is as follows.

$$\nu_{\gamma\text{-rays}} > \nu_{X\text{-rays}} > \nu_{UV}$$

$$B > A > C$$

38. (a) : Here, $I_B = 5 \mu\text{A} = 5 \times 10^{-6} \text{ A}$

$$\beta = 100$$

$$R_L = 10 \text{ k}\Omega = 10 \times 10^3 \Omega$$

$$\text{As } \beta = \frac{I_C}{I_B}$$

$$\text{or } I_C = (100)(5 \times 10^{-6} \text{ A}) = 5 \times 10^{-4} \text{ A}$$

The voltage across collector emitter is

$$V_{CE} = R_L I_C = (10 \times 10^3 \Omega)(5 \times 10^{-4} \text{ A}) = 5 \text{ V}$$

39. (b) : After a long time the capacitor has become fully charged, the entire battery voltage 60 V appears across the capacitor.

40. (d) : Emission of α -particle decreases the mass number and the atomic number by 4 and 2 respectively. Emission of β -particle increases the atomic number by 1 while the mass number remains unchanged.

After the emission of the one α -particle and two β -particles

Decreases in mass number = $4 - 0 = 4$

Decreases in atomic number = $2 - 2 = 0$

\therefore The resulting nucleus is ${}^{m-4}_{n}X$.
i.e. the isotope of the given nucleus.

41. (a) : Maximum air flow due to convection does not occur at the north pole but it occurs at 30° N pole because there is a maximum temperature difference between equator and 30° N at poles.

42. (c) : Lenses have different refractive index for different wavelengths of light. The refractive index decreases with increasing wavelength. So red light will bend least and violet the most. This will result in slight dispersion which will be seen as chromatic aberration.

43. (d) : If a material is in contact with another material, the surface energy depends on the interaction of molecules of the materials. If the molecules of the materials attract each other, surface energy is reduced and when they repel each other, the surface energy is increased. Thus the surface energy depends on both the materials, so both the assertion and reason are false.

44. (b)

45. (a) : Animate object do not obey Newton's second law, so it can accelerate in the absence of external force.

46. (a) : Magnetic field due to a circular loop carrying current I is given as

$$B = \frac{\mu_0}{4\pi} \frac{2\pi I r^2}{(r^2 + x^2)^{3/2}}$$

where, r = radius of loop

x = distance from centre of loop

For large distances, ($x \gg r$),

$$\therefore B = \frac{\mu_0}{4\pi} \frac{2IA}{x^3} = \frac{\mu_0}{4\pi} \frac{2M}{x^3}$$

where $M = IA$ = magnetic dipole moment of current loop which is equal to the magnetic field due to magnetic dipole.

Thus, the current loop can be considered as a magnetic dipole.

47. (b)

48. (b)

49. (b) : In telescope to have a large magnifying power, focal length of objective lens is kept large. To increase the magnifying power and resolving power, aperture of the objective lens is made large.

50. (a) : We know that $E = -\frac{13.6}{n^2} \text{ eV}$

It shows that total energy of electron in a stationary orbit in a hydrogen atom is negative, which means the electron is bound to the nuclear and is not free to leave it.

51. (c) : According to law of equipartition of energy, in thermal equilibrium, at temperature T , each degree of freedom of translational, rotational and vibrational motion contributes an average energy

equal to $\frac{1}{2}k_B T$. The vibrational motion has two types of energy associated with the vibrations along the length of the molecule-kinetic energy and potential energy. Thus, it contributes two degrees of freedom. Thus vibrational energy $= 2 \times \frac{1}{2}k_B T = k_B T$.

52. (b) : Superconductor is both a perfect diamagnetic substance as well as a perfect conductor.

53. (b) : Electrostatic field is a conservative field which means work done by an electrostatic field in moving a charge from one point to another depends only on the initial and the final positions and is independent of the path taken to go from one point to the another.

54. (a) : Cyclotron is used to accelerate charged particles to high energies. It uses both electric and magnetic fields together to increase the energy of the charged particle.

55. (a)

56. (b) : Electromagnetic waves are those waves in which there are sinusoidal variation of electric and magnetic field vectors at right angles to each other as well as at right angles to the direction of wave propagation. They are self-sustaining oscillations of electric and magnetic fields in free space or vacuum.

57. (b) : Gauss's theorem is based on inverse square dependence of electric field on distance.

58. (b)

59. (a)

60. (b)

CHEMISTRY

61. (b) : Following the conservation of energy principle,

$$\text{Kinetic energy } \left(\frac{1}{2} m_e v^2 \right) = h(\nu - \nu_0)$$

$$= (6.626 \times 10^{-34} \text{ J s}) (1 \times 10^{14} \text{ s}^{-1} - 5 \times 10^{13} \text{ s}^{-1})$$

$$= (6.626 \times 10^{-34} \text{ J s}) (5 \times 10^{13} \text{ s}^{-1})$$

$$= 3.313 \times 10^{-20} \text{ J}$$

62. (b) : The ring attached to the nitrogen atom in benzamide is strongly activated towards electrophilic substitution reaction.

\therefore Nitration occurs at p -position to the ring attached to 'N' atom.

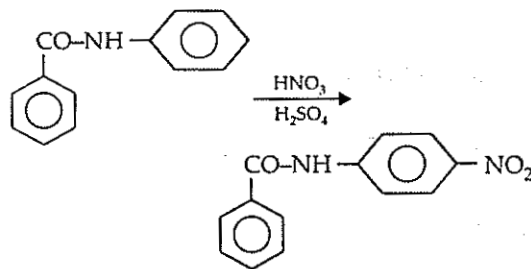

63. (b) :

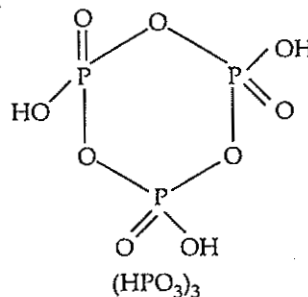

64. (a)

65. (d)

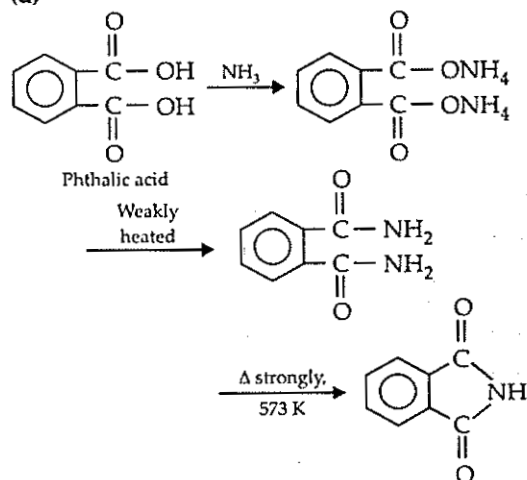

66. (a) : bcc has eight atoms at corners and each is shared by 8 unit cells so that the contribution of each atom at corner is $\frac{1}{8}$.

67. (c) : Greater are the intermolecular forces of attraction, higher is the critical temperature.

68. (c) : Dissociation energy of methane = 360 kJ mol^{-1}

$$\therefore \text{Bond energy of C—H bond} = \frac{360}{4} = 90 \text{ kJ}$$

Bond energy of ethane,

$$1(\text{C—C}) + 6(\text{C—H}) = 620 \text{ kJ/mol}$$

$$(\text{C—C}) + 6 \times 90 = 620$$

$$(\text{C—C}) + 540 = 620$$

$$\text{C—C} = 620 - 540$$

$$\text{C—C} = 80 \text{ kJ mol}^{-1}.$$

Bond dissociation of C—C bond = 80 kJ mol^{-1} .

69. (c) : Silicon is hydrophobic.

70. (d) : $mvr = \frac{nh}{2\pi}$

71. (d) : Copper (I) compounds are unstable in aqueous solution and undergo disproportionation.

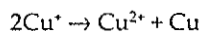

The greater stability of $\text{Cu}^{2+}_{(aq)}$ than $\text{Cu}^+_{(aq)}$ is due to much more $-ve \Delta_{hyd}H$ of $\text{Cu}^{2+}_{(aq)}$ than $\text{Cu}^+_{(aq)}$, which more than compensates for the second ionisation enthalpy of Cu.

72. (a) : Rate = $\frac{\text{concentration}}{\text{time}} = \frac{\text{mol L}^{-1}}{\text{s}}$
= $\text{mol L}^{-1} \text{ s}^{-1}$

The units of rate constant for the reaction of the order = $(\text{mol L}^{-1})^{1-n} \text{ s}^{-1}$

here, $n = \frac{3}{2}$

$$\therefore \text{Unit of rate constant} = (\text{mol L}^{-1})^{1-3/2} \text{ s}^{-1}$$

$$= (\text{mol L}^{-1})^{-1/2} \text{ s}^{-1}$$

$$= \text{mol}^{-1/2} \text{ L}^{1/2} \text{ s}^{-1}$$

73. (b) : Nitrogen is more electronegative and smaller in size than phosphorus. Therefore, the lone pair is concentrated on a small region and has maximum electron density. So, NH_3 is more basic than PH_3 .

74. (b) : Silicon belongs to group 14, it is doped with a group 13 element like B which contains only three valence electrons. The place where the fourth valence e^- is missing is called electron hole.

Under the electric field, e^- holes moves toward the negatively charged plate, which implies that e^- holes are positively charged, thus it is a p -type semiconductor.

75. (b) : NH_4Cl solution is acidic, its $\text{pH} < 7$. NaNO_3 solution is neutral, its $\text{pH} = 7$. CH_3COOK and Na_2CO_3 solutions are basic their $\text{pH} > 7$. But Na_2CO_3 solution is more basic, its $\text{pH} > \text{pH}$ of CH_3COOK solution.

76. (c) : Carbon monoxide combines with haemoglobin of blood to form a complex called carboxy-haemoglobin. Formation of this complex makes the haemoglobin incapable of oxygen transport. Due to which there will be oxygen deficiency in the blood.

77. (a) :

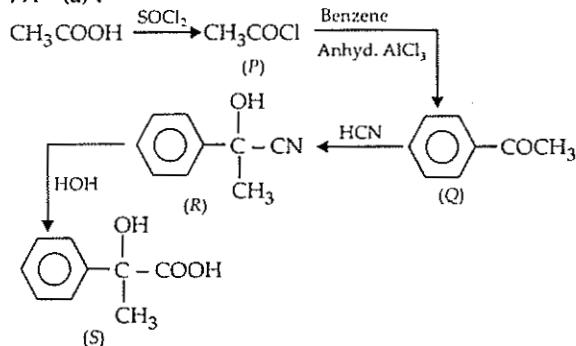

78. (d) : Chiral compound contains one or more 'chiral' carbon atom(s). Chiral carbon atoms are usually bonded to four different atoms or group of atoms.

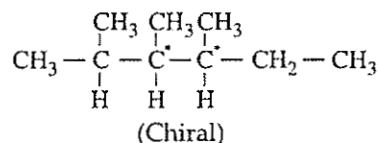
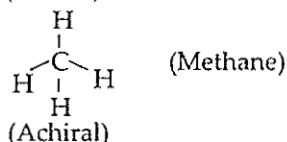
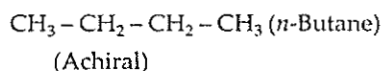
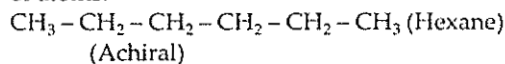

(2, 3, 4-Trimethylhexane.)

79. (b) : $E_{\text{cell}}^\circ = E_{\text{right}}^\circ - E_{\text{left}}^\circ$

$$E_{\text{cell}}^\circ = 0 - (0 - 0.76) = 0.76 \text{ V}$$

80. (c) : $\Delta n_g = n_p - n_r = 1 - \frac{3}{2}$

$$\Delta n_g = \frac{-1}{2}. \text{ Hence } K_p = K_c(RT)^{-1/2}$$

$$\frac{K_p}{K_c} = \frac{1}{(RT)^{1/2}} = \frac{1}{\sqrt{RT}}$$

81. (d) : For a n^{th} order reaction,

$$t_{1/2} \propto \frac{1}{[a]^{n-1}}$$

where n = order of reaction

$$t_{1/2} \propto \frac{1}{[a]^{3-1}} \quad [\therefore n = 3]$$

$$t_{1/2} \propto \frac{1}{[a]^2}$$

82. (c) : In the body-centred cubic unit cell,

$$a\sqrt{3} = 4r$$

$$r = \frac{a\sqrt{3}}{4} = \frac{400\sqrt{3}}{4} = 100\sqrt{3} \text{ pm}$$

83. (a)

84. (a) : In acidic solution, manganese (VI) becomes unstable and undergo disproportionation to form manganese (VII) and manganese (IV)

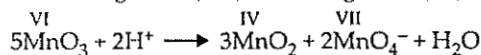

85. (a) : $\text{Cr}^{2+} = 3d^4$, No. of unpaired electrons (n) = 4

$$\text{Magnetic moment} = \sqrt{n(n+2)} \text{ BM}$$

$$= \sqrt{4(4+2)} = \sqrt{24} = 4.89 \text{ BM}$$

$\text{Fe}^{2+} = 3d^6$, No. of unpaired electrons (n) = 4

$$\text{Magnetic moment} = \sqrt{4(4+2)} \text{ BM}$$

$$= \sqrt{24} = 4.89 \text{ BM}$$

$\text{Mn}^{2+} = 3d^5$, No. of unpaired electrons (n) = 5

$$\text{Magnetic moment} = \sqrt{5(5+2)} \text{ BM}$$

$$= \sqrt{35} = 5.91 \text{ BM}$$

$\text{Co}^{2+} = 3d^7$, No. of unpaired electrons (n) = 3

$$\text{Magnetic moment} = \sqrt{3(3+2)} \text{ BM}$$

$$= \sqrt{15} = 3.87 \text{ BM}$$

$\text{Ni}^{2+} = 3d^8$, No. of unpaired electrons (n) = 2

$$\text{Magnetic moment} = \sqrt{2(2+2)} \text{ BM}$$

$$= \sqrt{8} = 2.82 \text{ BM}$$

86. (b) : (1) and (4) compounds are *meso*-compounds, they possess a plane of symmetry and are consequently optically inactive and superimpose on its mirror image (*i.e.*, they are identical).

87. (c)

88. (c) : The difference in atomic radius is maximum between Na and K.

89. (d) : BF_3 has zero dipole moment.

90. (b) : Isomers of C_5H_6 :

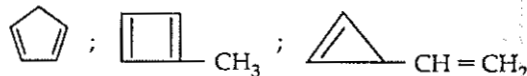

91. (b) : $\text{N}_2\text{O}_4 \rightleftharpoons 2\text{NO}_2$

Initially 1 0

At equilibrium $1 - \alpha$ 2α

N_2O_4 is 50% dissociated, so $\alpha = \frac{1}{2}$

$$K_p = \frac{p_{\text{NO}_2}^2}{p_{\text{N}_2\text{O}_4}} = \frac{\left(2 \times \frac{1}{2}\right)^2}{\left(1 - \frac{1}{2}\right)} = 2 \text{ atm}$$

92. (d) : Larger the value of pK_a , smaller will be its acidity. Out of the four groups, $-\text{COOH}$, $-\text{NO}_2$ and $-\text{CN}$ are e^- withdrawing which makes benzoic acid more acidic whereas $-\text{OCH}_3$ is e^- donating which reduces the acidity (makes H^+ less easily available). pK_a value increases if $-\text{OCH}_3$ is present at *para*-position of benzoic acid.

93. (c) : The structure of peroxodisulfate anion is:

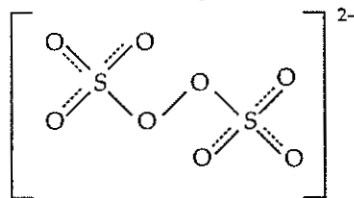

It has a O-O bridge.

94. (a) : N-N bond length is minimum in N_2O .

Compound	Structure
N_2O	<p>Linear</p>
N_2O_3	<p>Planar</p>

Oxoacids of phosphorus which contain P — H bond act as reducing agents and reduce metal salts to free metals. Thus, H_3PO_2 act as reducing agent while H_3PO_4 does not.

104. (c) : In diamond, C-atoms are sp^3 hybridized while in graphite, they are sp^2 hybridized.

105. (b) : Bohr model does not explain the spectra of multi-electron atoms.

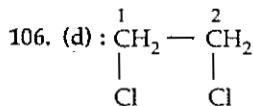

Since it has no chiral carbon, it is optically inactive. Meso compounds are optically inactive.

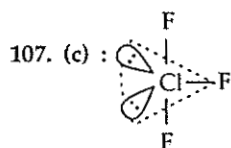

ClF_3 (T-shape)

The lone pairs are at equatorial position (120° angle).

108. (c) : Oxygen has two unpaired electrons. So it is paramagnetic.

109. (b) : $-\text{OH}$ group shows +M effect and is an activating group, moreover the arenium ion of phenolic substitution is more stable.

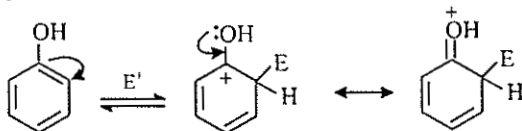

110. (c) : S is more electronegative than Se.

111. (b) : Fluorine has higher standard electrode potential (reduction potential) than iodine.

112. (a) : The element which can reduce itself acts as an oxidising agent.

113. (a) : All species like He^+ , Li^{2+} , Be^{3+} having one electron are expected to have similar spectrum as that of hydrogen.

114. (c) : Cl_2 is an oxidising agent. It bleaches the articles permanently by oxidation in presence of moisture.

115. (a) : Due to lanthanide contraction, the size of Lu^{3+} is increased and therefore $\text{Lu}(\text{OH})_3$ shows more covalent character (Large cation, more is covalent character - Fajan's rule). Thus $\text{La}(\text{OH})_3$ is more ionic and thus more basic.

116. (a)

117. (a) : $\text{Fe}^+ : [\text{Ar}] 3d^6 4s^1$

When the weak field ligand H_2O and strong field ligand NO attack, the configuration changes as follows:

$\text{Fe}^+ : [\text{Ar}] 3d^7 4s^0$

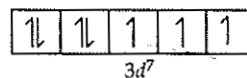

$\therefore \text{Fe}^+$ has 3 unpaired electrons.

118. (a) : This is according to Henry's law which states that the solubility of a gas in given volume of a liquid at a particular temperature is directly proportional to the pressure of gas above the liquid. $m \propto p$, $m = kp$ where k = Henry's constant.

119. (a) : $\text{HC}\equiv\text{C}^-$ has 50% s -character and $\text{H}_2\text{C}=\text{CH}^-$ has 33% s -character. Stability of carbanions increases with an increase in the s -character at the carbanion. So $\text{HC}\equiv\text{C}^-$ is more stable than $\text{H}_2\text{C}=\text{CH}^-$.

120. (c) : In pressure cooker, water boils above 100°C . When the lid of cooker is opened, pressure is lowered so that boiling point decreases and water boils again.

BIOLOGY

121. (b) : In frog three types of respiration occurs to suit its amphibious mode of life. These are cutaneous, buccopharyngeal and pulmonary respiration. Cutaneous respiration occurs through the thin, moist, highly vascular and naked skin. It takes place in water as well as on land. Buccopharyngeal respiration occurs on land *via* thin, vascular, moist lining of buccopharyngeal cavity. Pulmonary respiration takes place when the frog is outside the water. It occurs by lungs of adult frog.

122. (b) : Fasciculated root is a type of adventitious root. In this case, roots are swollen which occur in clusters from lower nodes of stems, e.g., *Asparagus*, *Dahlia*, etc.

123. (d) : The blastomeres in the blastocyst are arranged into an outer layer called trophoblast and an inner group of cells attached to trophoblast called the inner cell mass. Inner cell mass looks like a small knob at one pole which gives rise to the embryo and is called the embryonal knob. The trophoblast does not take part in the formation of the embryo proper. It remains external to the

- embryo and gives rise to the extraembryonic membranes, namely, chorion and amnion, for the protection and nourishment of the embryo. The trophoblast cells in contact with the embryonal knob are known as cells of Rauber.
124. (d) : The given figure shows population growth curve, in which A is carrying capacity, B is exponential growth curve and C is logistic growth curve.
125. (b) : Deuteromycetes are commonly known as imperfect fungi because only the asexual or vegetative stages of these fungi are known. The deuteromycetes reproduce only by asexual spores known as conidia. The mycelium is septate and branched. Some members are saprophytes or parasites while a large number of them are decomposers of litter and help in mineral cycling. Some examples are *Alternaria*, *Colletotrichum* and *Trichoderma*.
126. (d) : Abscisic acid acts as a general plant growth inhibitor and an inhibitor of plant metabolism. ABA inhibits seed germination. ABA stimulates the closure of stomata in the epidermis and increases the tolerance of plants to various kinds of stresses. Therefore, it is also called the stress hormone.
127. (c) : Parturition is induced from the fully developed foetus and the placenta. Parturition involves foetal ejection reflex which are mild contractions of the placenta. This reflex triggers release of oxytocin from the maternal pituitary which acts on the uterine muscles and causes stronger uterine contractions and that further stimulates secretion of oxytocin. This stimulatory reflex between uterine muscle contraction and oxytocin secretion continues resulting in stronger contractions and eventually leading into expulsion of the baby out of the uterus.
128. (d)
129. (b) : Sodium-potassium pump ($\text{Na}^+\text{-K}^+$) is a membrane transport protein that exchanges sodium ions (Na^+) for potassium ions (K^+). It transports 3 Na^+ outwards for 2 K^+ into the cell, thus maintaining the differential concentrations of each ion across the plasma membrane. The process requires energy in the form of ATP, being a form of active transport.
130. (c)
131. (d) : Photorespiration is the light dependent process of oxygenation of ribulose biphosphate (RuBP) and release of carbon dioxide by the photosynthetic organs of a plant. Normally photosynthetic organs do the reverse in the light, i.e., uptake of CO_2 and release of O_2 . At high temperature, RuBP carboxylase functions as oxygenase and instead of fixing carbon dioxide (C_3 cycle), oxidises ribulose 1, 5-biphosphate to produce a 3-carbon phosphoglyceric acid and a 2-carbon phosphoglycolate. Photorespiration does not produce energy or reducing power. Rather, it consumes energy. Further, it undoes the work of photosynthesis. There is 25% loss of fixed CO_2 . Therefore, photorespiration is a highly wasteful process. This happens only in case of C_3 plants. C_4 plants have overcome the problem of photorespiration.
132. (c) : Phase contrast microscope was developed by Zernicke (1935, Nobel Prize 1953) to observe living cells and the events occurring in them (e.g., Spindle formation, movement of chromosomes, endocytosis, exocytosis). It is similar to optical microscope except that it has an annular diaphragm in the condenser and a transparent phase plate at the back focal plane of objective. The microscope converts differences in refractive indices into differences in brightness.
133. (d) : A - Basilar membrane
B - Scala media
C - Reissner's membrane
D - Tectorial membrane
134. (c) : The net gain from complete oxidation of a glucose molecule in aerobic respiration is 36 ATP molecules. 10 molecules of NADH_2 (2 from Glycolysis + 8 from Krebs' cycle) yield $= 10 \times 3 = 30$ ATP, 2 molecules of FADH_2 yield $= 2 \times 2 = 4$ ATP and glycolysis also yields 2 ATP. Therefore, total release of ATP per hexose will be $= 30 + 4 + 2 = 36$ ATP.
135. (a)
136. (c)
137. (c) : A - Photosystem I (PS I)
B - Photosystem II (PS II)
C - e- acceptor
D - LHC(Light Harvesting Complex).
138. (a) : Muscle contraction is brought about by sliding of the actin filaments over myosin

filaments. When a muscle fibril contracts, its A band remains constant and I band shortens. H zone also disappears as the actin filaments of both sides in each sarcomere may overlap each other at M line.

139. (c) : When an impulse arrives at the synaptic knob of the axon, it depolarizes the presynaptic membrane and increases its permeability to calcium ions (Ca^{2+}). Ca^{2+} ions from the synaptic cleft pass into the synaptic knob via voltage-gated channels. Sudden rise in the cytosolic concentration of Ca^{2+} , causes the release of a chemical, called neurotransmitter substance, from small synaptic vesicles present there into the synaptic cleft by exocytosis through the presynaptic membrane.
140. (b) : Cattle ranching refers to practice of raising grazing livestock such as cattle or sheep for meat and wool, etc. The area of landscape meant primarily for cattle ranching is called a ranch. The practice has led to accelerated deforestation and contributed to increased methane gas concentration in atmosphere. Whatever cattle eat; is subjected to the action of methanogens (bacteria) harbouring the stomach (rumen) of cattle. The action of these bacteria on food material produces methane gas which is released through cattle fart into the earth's atmosphere where it absorbs heat just like carbon dioxide, contributing to global warming.
141. (b) : The C_4 plants are adapted to dry tropical regions and have greater productivity of biomass. They have special type of leaf anatomy known as Kranz anatomy. In this type of anatomy the bundle sheath cells form several layers around the vascular bundles; they are characterized by having a large number of chloroplasts, thick walls impervious to gaseous exchange and no intercellular spaces.
142. (a) : Colchicine is an alkaloid derived from the autumn crocus, *Colchicum autumnale*. It inhibits spindle formation in cells during mitosis so that chromosomes cannot separate during anaphase, thus inducing multiple sets of chromosomes. It does not affect cytokinesis.
143. (b) : The adrenal medulla secretes two hormones called adrenaline or epinephrine and noradrenaline or norepinephrine. These are commonly called as catecholamines. These are rapidly secreted in response to stress of any kind and during emergency situations and are called emergency hormones or hormones of fight or flight. These hormones increase alertness, pupillary dilation, piloerection (raising of hairs), sweating, etc. Both the hormones increase the heart beat, the strength of heart contraction and the rate of respiration. Catecholamines also stimulate the breakdown of glycogen, lipids and proteins.
144. (b) : The structure in option (b) is of a basophil. Basophils are granular WBCs and are the least (0.5– 1 per cent) of the total WBCs. They secrete histamine, serotonin, heparin, etc. and are involved in inflammatory reactions.
145. (a)
146. (b) : Bohr's effect is the phenomenon whereby the affinity of the respiratory pigment i.e., haemoglobin in the blood for oxygen is reduced when the level of carbon dioxide is increased. An increase in carbon dioxide concentration makes the blood more acidic which results in decrease in the efficiency of the uptake of oxygen by haemoglobin molecules. This facilitates gaseous exchange, because more oxygen is released in the tissues where the amount of carbon dioxide is rising due to metabolic activity. In its reverse, more oxygen is taken up at the lungs where the amount of carbon dioxide is low.
147. (d) : Bacteria like *Rhizobium* and *Frankia* live free as aerobes in the soil but are unable to fix nitrogen. They develop the ability to fix nitrogen only as a symbiont when they become anaerobic. They are unable to fix nitrogen by themselves. Roots of a legume secrete chemical attractants. Bacteria collect over the root hairs and form an infection thread enclosing the bacteria. Infection thread grows along with multiplication of bacteria. Bacteria stop dividing and form irregular polyhedral structures called bacteroids. In an infected cell bacteroids occur in groups surrounded by host membrane. The host cell develops a pinkish pigment called leghaemoglobin (Lb). It is oxygen scavenger and is related to blood pigment haemoglobin. It protects nitrogen fixing enzyme nitrogenase from oxygen.
148. (b)

149. (d) : Segmentation occurs in three highly organized phyla-annelida (earthworm), arthropoda (*Periplaneta*) and chordates. The body is often divided both externally and internally into a number of segments (metameres) e.g., annelids. Segmentation is mostly external in arthropods and mainly internal in man and other chordates.
150. (a)
151. (a) : G_0 phase is the stage of inactivation of cell cycle due to non-availability of mitogens and energy rich compounds. The cells in this phase remain metabolically active and usually grow in size assuming particular shape (cell differentiation). Cell enters G_0 phase from a cell cycle checkpoint in the G_1 phase. G_1 phase checkpoint (restriction point) takes the key decision whether the cell should divide, delay division or enter resting stage. Cells then remain in G_0 phase until there is a reason for them to divide. Several biocatalysts can help a cell in G_0 phase to proceed through cell division when required.
152. (a) : The "beads-on-a-string" structure is seen in electron microscope of isolated metaphase chromosomes. The chromonema form the gene bearing portions of the chromosome. Basically chromonema is made up of nucleosome chains. Nucleosome chain gives a beads on string appearance under electron microscope. Nucleosome is the fundamental packaging unit in eukaryotic chromosomes.
153. (b) : RNAi is a regulatory mechanism for an estimated 30% of all protein-coding genes (in mammals). It helps to protect cells against certain viruses by targeting viral RNA for destruction. It helps to silence potentially disruptive transposons in the genome by destroying RNA copies arising from transposon replication. RNAi is a precise and efficient tool for knockout of specific genes when studying gene function in experimental organisms. It also has potential for new forms of targeted gene therapy.
154. (c) : Alkaloids - Morphine, Codeine
Pigments- Carotenoids, Anthocyanin
Drugs- Vinblastin, Curcumin.
155. (c) : Four main types of commercial tea are generally recognized in the trade. These are black tea (China, India, Sri Lanka), green tea (China, Japan and Taiwan), oolong tea (Taiwan) and brick tea (China). Dust or fannings are left over small part of tea leaves, which are also widely used.
156. (c) : The cardiac cycle consists of one heart beat or one cycle of contraction and relaxation of the cardiac muscle. The contraction phase is called the systole while the relaxation phase is called the diastole.
157. (c) : The given floral diagram is of liliaceae family. This family is a characteristic representative of monocot plants. Most plants of this family are good ornamentals, source of medicine, vegetables and colchicine.
158. (c) : Particulate matter mainly includes dust, soot particles, volatile hydrocarbons, some sulphate and metallic residues emitted into the air by sources such as factories, power plants, vehicles, etc. PM is usually divided into different classes based on size ranging from total suspended matter (TSP) to PM-10 (particles with diameter of $10\ \mu$ or less) to PM-2.5 (particles with diameter of $2.5\ \mu$ or less). Smallest particles pose highest human health risk. Larger particles ($\leq 10\ \mu$) can easily be expelled from lungs through mucus but finer particles ($\leq 2.5\ \mu$) penetrate deep in lungs and can cause severe lung damage including lung cancer.
159. (c) : Pebrine or pepper disease is caused by protozoan *Nosema bombycis*. The parasite infects eggs and is therefore, transmitted to next generation. It kills caterpillars.
160. (b) : Homopolysaccharides or homoglycans are those complex carbohydrates which are formed by polymerization of only one type of monosaccharide monomers. For example, starch, glycogen, inulin, cellulose, chitin, etc. Agar, pectin, hyaluronic acid, heparin, etc., are heteropolysaccharides.
161. (b) : Hot spots are areas with high density of biodiversity or megadiversity which are also the most threatened ones. Ecologically hot spots are determined by four factors.
- Number of species/species diversity.
 - Degree of endemism
 - Degree of threat to habitat due to its degradation and fragmentation.
 - Degree of exploitation.

Myers (1988) initially identified 12 hot spots. Today the number of hotspots identified by ecologists is 34 covering an area less than 2% of land surface with about 20% of human population living there.

162. (b) : When the offsprings are produced by self fertilization or breeding between closely related parents it is called inbreeding. Inbreeding results in increase in homozygosity. The most revealing impact of inbreeding is the loss of vigour and physiological efficiency of the organisms characterized by reduction in size. A number of lethal and defective characters appear in the population which has undergone inbreeding (selfing). This loss of fitness in the progenies or decline in character expression with decreased heterozygosity arising from self mating is known as inbreeding depression or inbreeding decline. Continued inbreeding reduces fertility and even productivity. But the inbreeding progeny with lethal and harmful recessive genes being homozygous express these traits which otherwise remain hidden in heterozygous individuals. Natural selection works upon these individuals and eliminate them. Gradually, such genes get eliminated from the population.
163. (a) : For aquatic organism salt concentration (measured as salinity in parts per thousand) is a major factor for their survival. Salinity of different aquatic habitats varies greatly. It is less than 5 per thousand parts, in inland waters, 30–35 per thousand parts in the sea and more than 100 per thousand parts in some hypersaline lagoons. Many fresh water animals cannot live for long in sea water and vice versa because of the osmotic problems they would face due to the change in relative tonicity of the surrounding water with cytoplasm. It may result into endosmosis or exosmosis according to the conditions. The tolerance of organisms to the salinity range varies. Some organisms are tolerant of a wide range of salinities and are called euryhaline e.g. salmon, while some can tolerate only a narrow range of salinity i.e., stenohaline e.g., shark.
164. (c) : In non-myelinated nerve fibres, the ionic changes are repeated over the membrane all along the length of the fibre. So, the action potential flows all along the membrane over the entire length of the fibre. But in myelinated fibres, the ionic changes and the consequent depolarisation can take place only at the nodes of Ranvier free from myelin sheath, because the myelin sheath between the nodes insulates the fibre and prevents its depolarisation. So, the action potential in effect jumps from one node to the next. This is called saltatory conduction of nerve impulses. Because of this, nerve impulses do not have to run all along the myelinated nerve fibre. This is why nerve impulses are conducted far more rapidly in myelinated fibres than in the non - myelinated ones.
165. (c) : Frogs are able to change the colour of their skins to match with that of the surroundings. It makes them hard to be noticed by enemies. This is a type of protective colouration known as camouflage not mimicry. Changes in colour are possible by dispersion or concentration of special amoeboid pigment cells in their skin.
166. (a) : Simple goitre or endemic goitre is the enlargement of thyroid gland accompanied with cretinism or myxoedema. It occurs in case of hyposecretion of thyroxine. To compensate for lower secretion of thyroxine from cells, thyroid gland enlarges to accommodate more secretory cells. It is caused due to dietary deficiency of iodine. To form normal quantities of thyroxine about 1 mg/week of ingested iodine is required in the form of iodides.
167. (b) : Sickle cell anaemia is an autosomal hereditary disorder in which the erythrocytes become sickle shaped. The disorder or disease is caused by the formation of an abnormal haemoglobin called haemoglobin-s denoted as Hbs. Thus, the genotype of an individual homozygous for sickle cell anaemia is written as HbsHbs.
168. (d) : Manganese (Mn) is a micronutrient. Excess of it in soil can cause manganese toxicity characterized by brown spots surrounded by chlorotic veins. It occurs due to (i) reduction in uptake of iron and magnesium (ii) inhibition of binding of magnesium to specific enzymes (iii) inhibition of calcium translocation into shoot apex. Therefore excess of manganese (Mn) causes deficiency of iron (Fe), magnesium (Mg) and calcium (Ca). Hence the toxicity symptoms of Mn are actually combined deficiency symptoms of Fe, Mg and Ca.

169. (a) : Females having 45 chromosomes (2A + X0) are affected with Turner's syndrome. Individuals having Turner's syndrome have female sexual differentiation but ovaries are rudimentary. Other associated phenotypes of this condition are short stature, webbed-neck, broad chest, lack of secondary sexual characteristics and sterility. Thus, any imbalance in the copies of the sex chromosomes may disrupt the genetic information necessary for normal sexual development.
170. (d) : In proximal convoluted tubule (PCT) about 65% of the glomerular filtrate is reabsorbed normally. Here most of the solutes are reabsorbed making the filtrate isotonic to blood plasma. HCO⁻₃ is not absorbed in PCT.
171. (b) : Classification involves hierarchy of steps, in which each step represents a rank or category, called taxonomic category or taxon. All taxa together constitute a taxonomic hierarchy as follows:
Species → Genus → Family → Order → Class → Phylum or division → Kingdom.
Most common characters among individual members are found in taxon species. Common characters decrease from species to kingdom and members of a kingdom have least number of common characters. Similarly, complexity of classification decreases from species to kingdom.
172. (c) : There are two types of food chains: grazing food chain and detritus food chain. Detritus food chains are those which start from the dead bodies of animals or fallen leaves etc. In terrestrial ecosystems, detritus food chain is the major conduit of energy flow, while in aquatic ecosystems, grazing food chain is the major conduit of energy flow. As the detritus food chains depend upon the dead organic matter hence, these are not directly dependent upon solar energy.
173. (c) : *Wuchereria* (*W.bancrofti* & *W.malayii*), the filarial worms cause a slowly developing chronic inflammation of the organs in which they live for many years, usually the lymphatic vessels of the lower limbs, and the disease is called filariasis. The pathogen spread from one human being to another through mosquitoes like *Culex* and to a less extent by *Anopheles* and *Aedes*. The parasite resides in lymph vessels, connective tissues and mesentery. It is manifested by lymphoedema accompanied by thickening of subcutaneous tissues and skin so that there is permanent swelling mostly of feet, legs, thighs, scrotal sacs, breast etc. In *Culex* and other mosquitoes females are blood sucking while males suck juices of flowers and fruits. Female *Culex* carries filarial worm from one person to another. It prefers to breed in dirty water near human habitation.
174. (b) : Retrovirus is an RNA-containing virus that converts its RNA into DNA by means of the enzyme reverse transcriptase. This enables it to become integrated into its host's DNA. Some retroviruses can cause cancer in animals they contain oncogenes (cancer-causing genes), which are activated when the virus enters its host cell and starts to replicate. The special properties of retroviruses make them useful as vectors for inserting genetic material into eukaryotic cells. The best-known retrovirus is HIV, responsible for AIDS in humans.
175. (a) : Leydig's cells or interstitial cells of testes are large, polygonal cells that lie in the connective tissue present between the seminiferous tubules. They secrete androgens, the male sex hormones e.g., testosterone into the blood. Androgens control male sexual characteristics including facial and pubic hairs.
176. (a) : During strenuous exercise, the muscle does not get sufficient oxygen to meet its energy needs immediately. So, it contracts anaerobically and accumulates lactic acid. During recovery, the oxygen consumption of the muscle far exceeds than that in the resting state. The extra oxygen consumed during recovery is called oxygen debt of the muscle.
177. (c) : Being insoluble in water, fats and oils form large immiscible droplets in aqueous media but the enzymes which hydrolyse fats and oils (called lipases) are insoluble in fats and soluble in water. Therefore, lipases can act only on the water adjoining surfaces of fat droplets. Evidently, the larger the surface area of fat droplets, the greater is the action of the lipase on them. We know that the smaller the size of a droplet, the larger is its surface area relative to its mass. Thus lipases can digest fat in significant amounts only when large fat droplets are broken into tiny droplets to form a fine emulsion. This is the reason why emulsification is so necessary for the digestion

of fats. Enzyme amylase, on the other hand, is a starch - hydrolysing enzyme which has no role in fat digestion.

178. (b) : Bilirubin is a yellow pigment which arises from the catabolism of red pigment haemoglobin of old and worn out RBCs. The pale yellow colour of blood plasma is largely due to the presence of bilirubin. It has to be excreted into the bile and from there it is excreted out of the body along with the faecal matter. If, all of the bilirubin can not be excreted from the body then the skin and mucous membranes assume a yellowish hue, giving rise to the condition called jaundice.
179. (a) : No taste sensation is evoked when distilled water is put on human tongue because man does not possess taste buds for tasting water. The taste buds present on the tongue send nerve impulses to the brain which actually perceives the taste sensation. Some mammals such as rhesus monkeys, pigs, cats and dogs possess some taste buds which send nerve impulses to the brain when distilled water is applied on them. It seems, therefore, that water may stimulate these taste buds to evoke taste sensation in these animals.
180. (d) : It is not oxytocin, but the hormone vasopressin (also known as antidiuretic hormone,

ADH) because it reduces the volume of urine by increasing the reabsorption of water from the urine in the distal convoluted tubules, collecting tubules and collecting ducts in the kidney. It does so by rendering the walls of those tubules permeable to water. Failure of secretion of vasopressin leads to a reduced renal reabsorption of water and a consequent elimination of a large volume of very dilute (hypotonic) urine.

Oxytocin is another hormone released by the posterior lobe of pituitary gland. Oxytocin contracts the mammary glands, smooth muscles of uterus. Uterine contractions, stimulated by oxytocin at the end of pregnancy, help in the child-birth or parturition, hence also called birth hormone. The oxytocin - induced contractions of the mammary gland muscles help in the flow of stored milk from the mammary glands, hence also called milk ejection hormone.

GENERAL KNOWLEDGE

- | | | | | |
|----------|----------|----------|----------|----------|
| 181. (b) | 182. (b) | 183. (b) | 184. (a) | 185. (b) |
| 186. (a) | 187. (d) | 188. (b) | 189. (d) | 190. (b) |
| 191. (c) | 192. (d) | 193. (a) | 194. (a) | 195. (b) |
| 196. (d) | 197. (c) | 198. (a) | 199. (a) | 200. (c) |



Chapterwise Index - '13

Physics • Chemistry • Biology

Use the index for topicwise analysis of
AIIMS paper and refer to these
questions when you are practising MCQs chapterwise.

PHYSICS		
Chapter's Name	Question No.	Total
Units and Dimensions	8	1
Motion in One Dimension		0
Motion in Two Dimensions	30, 36	2
Laws of Motion and Friction	4	1
Work, Power and Energy	57	1
Centre of Mass and Rotational Motion	18, 46, 56	3
Gravitation	11, 40	2
Properties of Matter		0
Oscillations	29, 58	2
Waves		0
Heat and Thermodynamics	13, 14, 15, 16, 17, 21, 35, 37, 39, 45	10
Electrostatics	7, 25, 43, 44, 48	5
Current Electricity	33, 53, 54	3
Thermal and chemical effects of current		0
Magnetic Effects of Current		0
Magnetism	9, 47, 59	3
Electromagnetic Induction and Alternating Current	12, 22, 32	3
Electromagnetic Waves	31, 52	2
Ray Optics	42, 50, 55, 60	4
Wave Optics	23, 27	2
Modern Physics	2, 3, 6, 24, 28, 38, 49, 51	8
Solids and Semiconductor Devices	10, 26, 34	3
Universe		0
Principles of Communication	1, 5, 19, 20, 42	5

CHEMISTRY		
Chapter's Name	Question No.	Total
Basic Concepts		0
Atomic Structure	92, 117	2
Periodic Properties	64	1
Chemical Bonding	66, 67	2
Nuclear Chemistry		0
Gaseous and Liquid States	113	1
Solid State	90, 111	2
Mole Concept & Solutions	88, 89	2
Colloids, Surface Chemistry & Catalysis	91, 96	2
Equilibrium	94, 105	2
Kinetics	61, 98, 115	3
Energetics	95, 112, 114, 116	4
Electrochemistry	93	1
Redox Reactions	68, 74, 118	3
Metallurgy	99, 119	2
Hydrogen and its Compounds	97	1
s-Block Elements	71	1
p-Block Elements	69, 101, 102, 120	4
d- and f-Block Elements	62, 63, 65, 70, 73	5
Complex Compounds	72, 103, 104	3
Purification and Analysis of Organic Compound		0
General Organic Chemistry		0
Aliphatic Hydrocarbons	85	1
Aromatic Hydrocarbons		0
Halogen Derivatives		0
Alcohols, Phenols and Ethers	76, 80, 81, 87, 109	5
Aldehydes and Ketones	78, 79, 107	3
Carboxylic acids & their derivatives	82, 106, 108	3
Organic Compounds Containing Nitrogen	83, 84, 86	3
Biochemistry	77, 110	2
Chemistry in Action	100	1
Environmental Chemistry	75	1

BIOLOGY		
Chapter's Name	Question No.	Total
General Biology		0
Biological Classification	150, 152	2
Kingdom Monera		0
Kingdom Fungi		0
Plant Kingdom	142	1
Cell and its Structural Components	154, 157, 170	3
Cell Reproduction	133, 172	2
Cell Respiration		
Biomolecules	132, 178, 179	3
Principles of Inheritance and Variation	144, 175	2
Molecular Basis of Inheritance		0
Plant Anatomy	153, 168	2
Plant Morphology	147	1
Plant Physiology	139, 159, 162, 176	4
Sexual Reproduction in Flowering Plants	131, 134, 135, 136	4

Ecology and Environment	123, 124, 158, 160, 169, 171	6
Animal Kingdom	121, 126, 161	3
Animal Tissue		0
Musculo-Skeletal System	149	1
Digestive System and Nutrition	143, 163, 177, 180	4
Respiratory System	155	1
Circulatory System	125, 151, 156, 164	4
Excretion and Osmoregulation	145	1
Nervous System and Sense Organs	148, 174	2
Endocrine System	140	1
Reproduction and Embryonic Development	127, 128, 165, 173	4
Human Health and Diseases	130	1
Evolution	129	1
Biotechnology	122, 137, 138	3
Applied Biology	141, 146, 166, 167	4