

NATIONAL ELIGIBILITY CUM ENTRANCE TEST NEET (UG), 2017 BOOKLET CODE-C (APRA)

Time : 3 hrs.

Answers & Solutions

Max. Marks : 720

Important Instructions :

1. The Answer Sheet is inside this Test Booklet. When you are directed to open the Test Booklet, take out the Answer Sheet and fill in the particulars on **Side-1** and **Side-2** carefully with **blue / black** ball point pen only.
2. The test is of **3 hours** duration and Test Booklet contains **180** questions. Each question carries **4** marks. For each correct response, the candidate will get **4 marks**. For each incorrect response, **one mark** will be deducted from the total scores. The maximum marks are **720**.
3. Use **Blue / Black Ball Point Pen only** for writing particulars on this page / marking responses.
4. Rough work is to be done on the space provided for this purpose in the Test Booklet only.
5. **On completion of the test, the candidate must hand over the Answer Sheet to the invigilator before leaving the Room / Hall. The candidates are allowed to take away this Test Booklet with them.**
6. The CODE for this Booklet is **C**. Make sure that the CODE printed on **Side-2** of the Answer Sheet is the same as that on this Booklet. In case of discrepancy, the candidate should immediately report the matter to the Invigilator for replacement of both the Test Booklet and the Answer Sheet.
7. The candidates should ensure that the Answer Sheet is not folded. Do not make any stray marks on the Answer Sheet. Do not write your Roll No. anywhere else except in the specified space in the Test Booklet / Answer Sheet.
8. Use of white fluid for correction is **NOT** permissible on the Answer Sheet.
9. Each candidate must show on demand his / her Admit Card to the Invigilator.
10. No candidate, without special permission of the Superintendent or Invigilator, would leave his / her seat.
11. The candidates should not leave the Examination Hall without handing over their Answer Sheet to the Invigilator on duty and sign the Attendance Sheet twice. **Cases where a candidate has not signed the Attendance Sheet second time will be deemed not to have handed over the Answer Sheet and dealt with as an unfair means case.**
12. Use of Electronic / Manual Calculator is prohibited.
13. The candidates are governed by all Rules and Regulations of the examination with regard to their conduct in the Examination Hall. All cases of unfair means will be dealt with as per Rules and Regulations of this examination.
14. No part of the Test Booklet and Answer Sheet shall be detached under any circumstances.
15. The candidates will write the Correct Test Booklet Code as given in the Test Booklet / Answer Sheet in the Attendance Sheet.

- The final proof for DNA as the genetic material came from the experiments of
 - Hargobind Khorana
 - Griffith
 - Hershey and Chase
 - Avery, Mcleod and McCarty

Answer (3)

Sol. Hershey and Chase gave unequivocal proof which ended the debate between protein and DNA as genetic material.

- Spliceosomes are **not** found in cells of
 - Bacteria
 - Plants
 - Fungi
 - Animals

Answer (1)

Sol. Spliceosomes are used in removal of introns during post-transcriptional processing of hnRNA in eukaryotes only as split genes are absent as prokaryotes.

- The pivot joint between atlas and axis is a type of
 - Saddle joint
 - Fibrous joint
 - Cartilaginous joint
 - Synovial joint

Answer (4)

Sol. Synovial joints are freely movable joint which allow considerable movements. Pivot joint is a type of synovial joint which provide rotational movement as in between atlas and axis vertebrae of vertebral column.

- The association of histone H1 with a nucleosome indicates:
 - The DNA double helix is exposed
 - Transcription is occurring
 - DNA replication is occurring
 - The DNA is condensed into a Chromatin Fibre

Answer (4)

Sol. The association of H1 protein indicates the complete formation of nucleosome.

Therefore the DNA is in condensed form.

- Which of the following is made up of dead cells?
 - Phloem
 - Xylem parenchyma
 - Collenchyma
 - Phellem

Answer (4)

Sol. Cork cambium undergoes periclinal division and cuts off thick walled suberised dead cork cells towards outside and it cuts off thin walled living cells i.e., phelloderm on inner side.

- Select the **correct** route for the passage of sperms in male frogs :

- Testes → Vasa efferentia → Kidney → Bidder's canal → Urinogenital duct → Cloaca
- Testes → Bidder's canal → Kidney → Vasa efferentia → Urinogenital duct → Cloaca
- Testes → Vasa efferentia → Kidney → Seminal Vesicle → Urinogenital duct → Cloaca
- Testes → Vasa efferentia → Bidder's canal → Ureter → Cloaca

Answer (1)

Sol. In male frog the sperms will move from

Testes → Vasa efferentia → Kidney → Bidder's canal → Urinogenital duct → Cloaca.

- Adult human RBCs are enucleate. Which of the following statement(s) is/are most appropriate explanation for this feature?
 - They do not need to reproduce
 - They are somatic cells
 - They do not metabolize
 - All their internal space is available for oxygen transport

Options :

- (b) and (c)
- Only (d)
- Only (a)
- (a), (c) and (d)

Answer (2)

Sol. In Human RBCs, nucleus degenerates during maturation which provide more space for oxygen carrying pigment (Haemoglobin). It lacks most of the cell organelles including mitochondria so respire anaerobically.

- Homozygous purelines in cattle can be obtained by
 - Mating of individuals of different species
 - Mating of related individuals of same breed
 - Mating of unrelated individuals of same breed
 - Mating of individuals of different breed

Answer (2)

Sol. Inbreeding results in increase in the homozygosity. Therefore, mating of the related individuals of same breed will increase homozygosity.

- A temporary endocrine gland in the human body is
 - Corpus allatum
 - Pineal gland
 - Corpus cardiacum
 - Corpus luteum

Answer (4)

Sol. Corpus luteum is the temporary endocrine structure formed in the ovary after ovulation. It is responsible for the release of the hormones like progesterone, oestrogen etc.

10. Viroids differ from viruses in having :
- (1) RNA molecules without protein coat
 - (2) DNA molecules with protein coat
 - (3) DNA molecules without protein coat
 - (4) RNA molecules with protein coat

Answer (1)

Sol. Viroids are sub-viral agents as infectious RNA particles, without protein coat.

11. A decrease in blood pressure/volume will not cause the release of
- (1) ADH
 - (2) Renin
 - (3) Atrial Natriuretic Factor
 - (4) Aldosterone

Answer (3)

Sol. A decrease in blood pressure / volume stimulates the release of renin, aldosterone, and ADH while increase in blood pressure / volume stimulates the release of Atrial Natriuretic Factor (ANF) which cause vasodilation and also inhibits RAAS (Renin Angiotensin Aldosterone System) mechanism that decreases the blood volume/pressure.

12. An example of colonial alga is
- | | |
|----------------------|----------------------|
| (1) <i>Spirogyra</i> | (2) <i>Chlorella</i> |
| (3) <i>Volvox</i> | (4) <i>Ulothrix</i> |

Answer (3)

Sol. *Volvox* is motile colonial fresh water alga with definite number of vegetative cells.

13. The morphological nature of the edible part of coconut is
- | | |
|---------------|---------------|
| (1) Pericarp | (2) Perisperm |
| (3) Cotyledon | (4) Endosperm |

Answer (4)

Sol. Coconut has double endosperm with liquid endosperm and cellular endosperm.

14. Which of the following is correctly matched for the product produced by them?
- (1) *Saccharomyces cerevisiae* : Ethanol
 - (2) *Acetobacter aceti* : Antibiotics
 - (3) *Methanobacterium* : Lactic acid
 - (4) *Penicillium notatum* : Acetic acid

Answer (1)

Sol. *Saccharomyces cerevisiae* is commonly called Brewer's yeast. It causes fermentation of carbohydrates producing ethanol.

15. Match the following sexually transmitted diseases (Column - I) with their causative agent (Column - II) and select the correct option.

Column - I	Column- II
(a) Gonorrhoea	(i) HIV
(b) Syphilis	(ii) <i>Neisseria</i>
(c) Genital Warts	(iii) <i>Treponema</i>
(d) AIDS	(iv) <i>Human Papilloma</i> virus

Options :

(a)	(b)	(c)	(d)
(1) (iv)	(ii)	(ii)	(i)
(2) (ii)	(iii)	(iv)	(i)
(3) (iii)	(iv)	(i)	(ii)
(4) (iv)	(ii)	(iii)	(i)

Answer (2)

Sol. Gonorrhoea – *Neisseria* (Bacteria)
 Syphilis – *Treponema* (Bacteria)
 Genital Warts – *Human papilloma virus* (Virus)
 AIDS – HIV (Virus)

16. In case of poriferans the spongocoel is lined with flagellated cells called :
- | | |
|-----------------------|-----------------|
| (1) Mesenchymal cells | (2) Ostia |
| (3) Oscula | (4) Choanocytes |

Answer (4)

Sol. Choanocytes (collar cells) form lining of spongocoel in poriferans (sponges). Flagella in collar cells provide circulation to water in water canal system.

17. Among the following characters, which one was not considered by Mendel in his experiments on pea?
- (1) Pod – Inflated or Constricted
 - (2) Stem – Tall or Dwarf
 - (3) Trichomes – Glandular or non-glandular
 - (4) Seed – Green or Yellow

Answer (3)

Sol. During his experiments Mendel studied seven characters.

Nature of trichomes *i.e.*, glandular or non-glandular was not considered by Mendel.

18. Identify the wrong statement in context of heartwood.
- (1) It comprises dead elements with highly lignified walls
 - (2) Organic compounds are deposited in it
 - (3) It is highly durable
 - (4) It conducts water and minerals efficiently

Answer (4)

Sol. Heartwood is physiologically inactive due to deposition of organic compounds and tyloses formation, so this will not conduct water and minerals.

19. During DNA replication, Okazaki fragments are used to elongate
- (1) The lagging strand away from the replication fork
 - (2) The leading strand towards replication fork
 - (3) The lagging strand towards replication fork
 - (4) The leading strand away from replication fork

Answer (1)

Sol. Two DNA polymerase molecules work simultaneous at the DNA fork, one on the leading strand and the other on the lagging strand.

Each Okazaki fragment is synthesized by DNA polymerase at lagging strand in $5' \rightarrow 3'$ direction. New Okazaki fragments appear as the replication fork opens further.

As the first Okazaki fragment appears away from the replication fork, the direction of elongation would be away from replication fork.

20. Mycorrhizae are the example of
- (1) Mutualism
 - (2) Fungistasis
 - (3) Amensalism
 - (4) Antibiosis

Answer (1)

Sol. Mycorrhizae is a symbiotic association of fungi with roots of higher plants.

21. Which of the following RNAs should be most abundant in animal cell?
- (1) mi-RNA
 - (2) r-RNA
 - (3) t-RNA
 - (4) m-RNA

Answer (2)

Sol. rRNA is most abundant in animal cell. It constitutes 80% of total RNA of the cell.

22. The process of separation and purification of expressed protein before marketing is called
- (1) Postproduction processing
 - (2) Upstream processing
 - (3) Downstream processing
 - (4) Bioprocessing

Answer (3)

Sol. Biosynthetic stage for synthesis of product in recombinant DNA technology is called upstreaming process while after completion of biosynthetic stage, the product has to be subjected through a series of processes which include separation and purification are collectively referred to as downstream processing.

23. Which among the following are the smallest living cells, known without a definite cell wall, pathogenic to plants as well as animals and can survive without oxygen?

- (1) *Nostoc*
- (2) *Bacillus*
- (3) *Pseudomonas*
- (4) Mycoplasma

Answer (4)

Sol. Mycoplasmas are smallest, wall-less prokaryotes, pleomorphic in nature. These are pathogenic on both plants and animals.

24. Which of the following components provides sticky character to the bacterial cell?

- (1) Glycocalyx
- (2) Cell wall
- (3) Nuclear membrane
- (4) Plasma membrane

Answer (1)

Sol. Sticky character of the bacterial wall is due to glycocalyx or slime layer. This layer is rich in glycoproteins.

25. With reference to factors affecting the rate of photosynthesis, which of the following statements is **not** correct?

- (1) Tomato is a greenhouse crop which can be grown in CO_2 - enriched atmosphere for higher yield
- (2) Light saturation for CO_2 fixation occurs at 10% of full sunlight
- (3) Increasing atmospheric CO_2 concentration upto 0.05% can enhance CO_2 fixation rate
- (4) C_3 plants responds to higher temperatures with enhanced photosynthesis while C_4 plants have much lower temperature optimum

Answer (4)

Sol. In C_3 plants photosynthesis is decreased at higher temperature due to increased photorespiration.

C_4 plants have higher temperature optimum because of the presence of pyruvate phosphate dikinase enzyme, which is sensitive to low temperature.

26. Which of the following options best represents the enzyme composition of pancreatic juice?

- (1) Lipase, amylase, trypsinogen, procarboxypeptidase
- (2) Amylase, peptidase, trypsinogen, rennin
- (3) Amylase, pepsin, trypsinogen, maltase
- (4) Peptidase, amylase, pepsin, rennin

Answer (1)

Sol. Rennin and Pepsin enzymes are present in the gastric juice. Maltase is present in the intestinal juice.

27. Which one of the following statements is **correct**, with reference to enzymes?

- (1) Holoenzyme = Coenzyme + Cofactor
- (2) Apoenzyme = Holoenzyme + Coenzyme
- (3) Holoenzyme = Apoenzyme + Coenzyme
- (4) Coenzyme = Apoenzyme + Holoenzyme

Answer (3)

Sol. Holoenzyme is conjugated enzyme in which protein part is apoenzyme while non-protein is cofactor.

Coenzyme are also organic compounds but their association with apoenzyme is only transient and serve as cofactors.

28. If there are 999 bases in an RNA that codes for a protein with 333 amino acids, and the base at position 901 is deleted such that the length of the RNA becomes 998 bases, how many codons will be altered?

- (1) 333
- (2) 1
- (3) 11
- (4) 33

Answer (4)

Sol. If deletion occurs at 901st position the remaining 98 bases specifying for 33 codons of amino acids will be altered.

29. Asymptote in a logistic growth curve is obtained when

- (1) $K < N$
- (2) The value of 'r' approaches zero
- (3) $K = N$
- (4) $K > N$

Answer (3)

Sol. A population growing in a habitat with limited resources shows logistic growth curve.

For logistic growth

$$\frac{dN}{dt} = rN \left(\frac{K - N}{K} \right)$$

$$\text{If } K = N \text{ then } \frac{K - N}{K} = 0$$

$$\therefore \text{the } \frac{dN}{dt} = 0,$$

the population reaches asymptote.

30. Select the mismatch :

- | | |
|----------------------|-----------------|
| (1) <i>Equisetum</i> | – Homosporous |
| (2) <i>Pinus</i> | – Dioecious |
| (3) <i>Cycas</i> | – Dioecious |
| (4) <i>Salvinia</i> | – Heterosporous |

Answer (2)

Sol. *Pinus* is monoecious plant having both male and female cones on same plant.

31. Anaphase promoting complex (APC) is a protein degradation machinery necessary for proper mitosis of animal cells. If APC is defective in a human cell, which of the following is expected to occur?

- (1) Recombination of chromosome arms will occur
- (2) Chromosomes will not condense
- (3) Chromosomes will be fragmented
- (4) Chromosomes will not segregate

Answer (4)

Sol. Anaphase Promoting Complex (APC) is a protein necessary for separation of daughter chromosomes during anaphase. If APC is defective then the chromosomes will fail to segregate during anaphase.

32. Which ecosystem has the maximum biomass?

- (1) Lake ecosystem
- (2) Forest ecosystem
- (3) Grassland ecosystem
- (4) Pond ecosystem

Answer (2)

Sol. High productive ecosystem are

- Tropical rain forest
- Coral reef
- Estuaries
- Sugarcane fields

33. Zygotic meiosis is characteristic of

- | | |
|--------------------------|-----------------------|
| (1) <i>Chlamydomonas</i> | (2) <i>Marchantia</i> |
| (3) <i>Fucus</i> | (4) <i>Funaria</i> |

Answer (1)

Sol. *Chlamydomonas* has haplontic life cycle hence showing zygotic meiosis or initial meiosis.

34. Hypersecretion of Growth Hormone in adults does not cause further increase in height, because

- (1) Muscle fibres do not grow in size after birth
- (2) Growth Hormone becomes inactive in adults
- (3) Epiphyseal plates close after adolescence
- (4) Bones lose their sensitivity to Growth Hormone in adults

Answer (3)

Sol. Epiphyseal plate is responsible for the growth of bone which close after adolescence so hypersecretion of growth hormone in adults does not cause further increase in height.

35. Frog's heart when taken out of the body continues to beat for some time

Select the best option from the following statements

- (a) Frog is a poikilotherm
- (b) Frog does not have any coronary circulation
- (c) Heart is "myogenic" in nature
- (d) Heart is autoexcitable

Options :

- (1) (c) & (d) (2) Only (c)
- (3) Only (d) (4) (a) & (b)

Answer (1)

Sol. Frog or the vertebrates have myogenic heart having self contractile system or are autoexcitable; because of this condition, it will keep on working outside the body for some time.

36. Transplantation of tissues/organs fails often due to non-acceptance by the patient's body. Which type of immune-response is responsible for such rejections?

- (1) Physiological immune response
- (2) Autoimmune response
- (3) Cell-mediated immune response
- (4) Hormonal immune response

Answer (3)

Sol. Non-acceptance or rejection of graft or transplanted tissues/organs is due to cell mediated immune response.

37. Thalassemia and sickle cell anemia are caused due to a problem in globin molecule synthesis. Select the correct statement.

- (1) Sickle cell anemia is due to a quantitative problem of globin molecules
- (2) Both are due to a qualitative defect in globin chain synthesis
- (3) Both are due to a quantitative defect in globin chain synthesis
- (4) Thalassemia is due to less synthesis of globin molecules

Answer (4)

Sol. Thalassemia differs from sickle-cell anaemia in that the former is a quantitative problem of synthesising too few globin molecules while the latter is a qualitative problem of synthesising an incorrectly functioning globin.

38. An important characteristic that Hemichordates share with Chordates is

- (1) Pharynx without gill slits
- (2) Absence of notochord
- (3) Ventral tubular nerve cord
- (4) Pharynx with gill slits

Answer (4)

Sol. Pharyngeal gill slits are present in hemichordates as well as in chordates. Notochord is present in chordates only. Ventral tubular nerve cord is characteristic feature of non-chordates.

39. Double fertilization is exhibited by

- (1) Angiosperms
- (2) Gymnosperms
- (3) Algae
- (4) Fungi

Answer (1)

Sol. Double fertilization is a characteristic feature exhibited by angiosperms. It involves syngamy and triple fusion.

40. Which of the following cell organelles is responsible for extracting energy from carbohydrates to form ATP?

- (1) Mitochondrion (2) Lysosome
- (3) Ribosome (4) Chloroplast

Answer (1)

Sol. Mitochondria are the site of aerobic oxidation of carbohydrates to generate ATP.

41. Lungs are made up of air-filled sacs the alveoli. They do not collapse even after forceful expiration, because of :

- (1) Expiratory Reserve Volume
- (2) Residual Volume
- (3) Inspiratory Reserve Volume
- (4) Tidal Volume

Answer (2)

Sol. Volume of air present in lungs after forceful expiration as residual volume which prevents the collapsing of alveoli even after forceful expiration.

42. Which of the following are not polymeric?
 (1) Lipids (2) Nucleic acids
 (3) Proteins (4) Polysaccharides

Answer (1)

Sol. – Nucleic acids are polymers of nucleotides
 – Proteins are polymers of amino acids
 – Polysaccharides are polymers of monosaccharides
 – Lipids are the esters of fatty acids and alcohol

43. Flowers which have single ovule in the ovary and are packed into inflorescence are usually pollinated by
 (1) Bat (2) Water
 (3) Bee (4) Wind

Answer (4)

Sol. Wind pollination or anemophily is favoured by flowers having a single ovule in each ovary, and numerous flowers packed in an inflorescence. Wind pollination is a non-directional pollination.

44. Life cycle of *Ectocarpus* and *Fucus* respectively are
 (1) Haplodiplontic, Haplontic
 (2) Haplontic, Diplontic
 (3) Diplontic, Haplodiplontic
 (4) Haplodiplontic, Diplontic

Answer (4)

Sol. *Ectocarpus* has haplodiplontic life cycle and *Fucus* has diplontic life cycle.

45. Presence of plants arranged into well defined vertical layers depending on their height can be seen best in :
 (1) Temperate Forest
 (2) Tropical Savannah
 (3) Tropical Rain Forest
 (4) Grassland

Answer (3)

Sol. The tropical rain forest have five vertical strata on the basis of height of plants. *i.e.*, ground vegetation, shrubs, short canopy trees, tall canopy trees and tall emergent trees.

46. Phosphonol pyruvate (PEP) is the primary CO₂ acceptor in :
 (1) C₃ and C₄ plants (2) C₃ plants
 (3) C₄ plants (4) C₂ plants

Answer (3)

Sol. PEP is 3C compound which serves as primary CO₂ acceptor in the mesophyll cell cytoplasm of C₄ plants like maize, sugarcane, *Sorghum* etc.

47. Good vision depends on adequate intake of carotene rich food

Select the best option from the following statements

- (a) Vitamin A derivatives are formed from carotene
 (b) The photopigments are embedded in the membrane discs of the inner segment
 (c) Retinal is a derivative of vitamin A
 (d) Retinal is a light absorbing part of all the visual photopigments

Options :

- (1) (b), (c) & (d) (2) (a) & (b)
 (3) (a), (c) & (d) (4) (a) & (c)

Answer (3)

Sol. Carotene is the source of retinal which is involved in formation of rhodopsin of rod cells. Retinal, a derivative of vitamin A, is the light-absorbing part of all visual photopigments.

48. Which one from those given below is the period for Mendel's hybridization experiments?
 (1) 1870 - 1877 (2) 1856 - 1863
 (3) 1840 - 1850 (4) 1857 - 1869

Answer (2)

Sol. Mendel conducted hybridization experiments on Pea plant for 7 years between 1856 to 1863 and his data was published in 1865 (according to NCERT).

49. Select the mismatch :

- (1) *Rhizobium* – *Alfalfa*
 (2) *Frankia* – *Alnus*
 (3) *Rhodospirillum* – *Mycorrhiza*
 (4) *Anabaena* – Nitrogen fixer

Answer (3)

Sol. *Rhodospirillum* is anaerobic, free living nitrogen fixer. Mycorrhiza is a symbiotic relationship between fungi and roots of higher plants.

50. Attractants and rewards are required for
 (1) Cleistogamy (2) Anemophily
 (3) Entomophily (4) Hydrophily

Answer (3)

Sol. Insect pollinated plants provide rewards as edible pollen grain and nectar as usual rewards. While some plants also provide safe place for deposition of eggs.

51. In case of a couple where the male is having a very low sperm count, which technique will be suitable for fertilisation?

- (1) Intracytoplasmic sperm injection
- (2) Intrauterine transfer
- (3) Gamete intracytoplasmic fallopian transfer
- (4) Artificial Insemination

Answer (4)

Sol. Infertility cases due to inability of the male partner to inseminate the female or due to very low sperm count in the ejaculates, could be corrected by artificial insemination (AI).

52. Which among these is the correct combination of aquatic mammals?

- (1) Trygon, Whales, Seals
- (2) Seals, Dolphins, Sharks
- (3) Dolphins, Seals, Trygon
- (4) Whales, Dolphins Seals

Answer (4)

Sol. Sharks and Trygon (sting ray) are the members of chondrichthyes (cartilaginous fish) while whale, Dolphin and Seals are aquatic mammals belong to class mammalia.

53. Functional megaspore in an angiosperm develops into

- (1) Embryo
- (2) Ovule
- (3) Endosperm
- (4) Embryo sac

Answer (4)

Sol. Megaspore is the first cell of female gametophytic generation in angiosperm. It undergoes three successive generations of free nuclear mitosis to form 8-nucleated and 7-celled embryo sac.

54. Root hairs develop from the region of

- (1) Meristematic activity
- (2) Maturation
- (3) Elongation
- (4) Root cap

Answer (2)

Sol. In roots, the root hairs arise from zone of maturation. This zone is differentiated zone thus bearing root hairs.

55. A dioecious flowering plant prevents both:

- (1) Cleistogamy and xenogamy
- (2) Autogamy and xenogamy
- (3) Autogamy and geitonogamy
- (4) Geitonogamy and xenogamy

Answer (3)

Sol. When unisexual male and female flowers are present on different plants the condition is called dioecious and it prevents both autogamy and geitonogamy.

56. The hepatic portal vein drains blood to liver from

- (1) Intestine
- (2) Heart
- (3) Stomach
- (4) Kidneys

Answer (1)

Sol. In hepatic portal system, hepatic portal vein carries maximum amount of nutrients from intestine to liver.

57. What is the criterion for DNA fragments movement on agarose gel during gel electrophoresis?

- (1) Negatively charged fragments do not move
- (2) The larger the fragment size, the farther it moves
- (3) The smaller the fragment size, the farther it moves
- (4) Positively charged fragments move to farther end

Answer (3)

Sol. During gel electrophoresis, DNA fragments separate (resolve) according to their size through sieving effect provided by agarose gel.

58. Which of the following represents order of 'Horse'?

- (1) Ferus
- (2) Equidae
- (3) Perissodactyla
- (4) Caballus

Answer (3)

Sol. Horse belongs to order perissodactyla of class mammalia. Perissodactyla includes odd-toed mammals.

59. Which statement is wrong for Krebs' cycle?

- (1) The cycle starts with condensation of acetyl group (acetyl CoA) with pyruvic acid to yield citric acid
- (2) There are three points in the cycle where NAD^+ is reduced to $\text{NADH} + \text{H}^+$
- (3) There is one point in the cycle where FAD^+ is reduced to FADH_2
- (4) During conversion of succinyl CoA to succinic acid, a molecule of GTP is synthesised

Answer (1)

Sol. Krebs cycle starts with condensation of acetyl CoA (2C) with oxaloacetic acid (4C) to form citric acid (6C).

60. Artificial selection to obtain cows yielding higher milk output represents

- (1) Stabilizing followed by disruptive as it stabilizes the population to produce higher yielding cows
- (2) Stabilizing selection as it stabilizes this character in the population
- (3) Directional as it pushes the mean of the character in one direction
- (4) Disruptive as it splits the population into two one yielding higher output and the other lower output

Answer (3)

Sol. Artificial selection to obtain cow yielding higher milk output will shift the peak to one direction, hence, will be an example of Directional selection. In stabilizing selection, the organisms with the mean value of the trait are selected. In disruptive selection, both extremes get selected.

61. The region of Biosphere Reserve which is legally protected and where no human activity is allowed is known as

- (1) Restoration zone (2) Core zone
- (3) Buffer zone (4) Transition zone

Answer (2)

Sol. Biosphere reserve is protected area with multipurpose activities.

It has three zones

- (a) Core zone – without any human interference
- (b) Buffer zone – with limited human activity
- (c) Transition zone – human settlement, grazing cultivation etc., are allowed.

62. Receptor sites for neurotransmitters are present on

- (1) Post-synaptic membrane
- (2) Membranes of synaptic vesicles
- (3) Pre-synaptic membrane
- (4) Tips of axons

Answer (1)

Sol. Pre-synaptic membrane is involved in the release of neurotransmitter in the chemical synapse. The receptors sites for neurotransmitters are present on post-synaptic membrane.

63. The vascular cambium normally gives rise to

- (1) Periderm (2) Phelloderm
- (3) Primary phloem (4) Secondary xylem

Answer (4)

Sol. During secondary growth, vascular cambium gives rise to secondary xylem and secondary phloem. Phelloderm is formed by cork cambium.

64. A baby boy aged two years is admitted to play school and passes through a dental check-up. The dentist observed that the boy had twenty teeth. Which teeth were absent?

- (1) Molars (2) Incisors
- (3) Canines (4) Pre-molars

Answer (4)

Sol. Total number of teeth in human child = 20. Premolars are absent in primary dentition.

65. The water potential of pure water is

- (1) More than one
- (2) Zero
- (3) Less than zero
- (4) More than zero but less than one

Answer (2)

Sol. By convention, the water potential of pure water at standard temperature, which is not under any pressure, is taken to be zero.

66. DNA fragments are

- (1) Either positively or negatively charged depending on their size
- (2) Positively charged
- (3) Negatively charged
- (4) Neutral

Answer (3)

Sol. DNA fragments are negatively charged because of phosphate group.

67. Capacitation occurs in

- (1) Female Reproductive tract
- (2) Rete testis
- (3) Epididymis
- (4) Vas deferens

Answer (1)

Sol. Capacitation is increase in fertilising capacity of sperms which occurs in female reproductive tract.

68. The function of copper ions in copper releasing IUD's is :
- (1) They inhibit ovulation
 - (2) They suppress sperm motility and fertilising capacity of sperms
 - (3) They inhibit gametogenesis
 - (4) They make uterus unsuitable for implantation

Answer (2)

Sol. Cu^{2+} interfere in the sperm movement, hence suppress the sperm motility and fertilising capacity of sperms.

69. A gene whose expression helps to identify transformed cell is known as
- (1) Structural gene
 - (2) Selectable marker
 - (3) Vector
 - (4) Plasmid

Answer (2)

Sol. In recombinant DNA technology, selectable markers helps in identifying and eliminating non-transformants and selectively permitting the growth of the transformants.

70. Which one of the following statements is not valid for aerosols?
- (1) They have negative impact on agricultural land
 - (2) They are harmful to human health
 - (3) They alter rainfall and monsoon patterns
 - (4) They cause increased agricultural productivity

Answer (4)

Sol. Aerosols can cause various problems to agriculture through its direct or indirect effects on plants. However continually increasing air pollution may represent a persistent and largely irreversible threat to agriculture in the future.

71. Which of the following statements is correct?
- (1) The descending limb of loop of Henle is permeable to electrolytes
 - (2) The ascending limb of loop of Henle is impermeable to water
 - (3) The descending limb of loop of Henle is impermeable to water
 - (4) The ascending limb of loop of Henle is permeable to water

Answer (2)

Sol. Descending limb of loop of Henle is permeable to water but impermeable to electrolytes while ascending limb is impermeable to water but permeable to electrolytes.

72. Which of the following in sewage treatment removes suspended solids?
- (1) Sludge treatment
 - (2) Tertiary treatment
 - (3) Secondary treatment
 - (4) Primary treatment

Answer (4)

Sol. Primary treatment is a physical process which involves sequential filtration and sedimentation.

73. GnRH, a hypothalamic hormone, needed in reproduction, acts on
- (1) Posterior pituitary gland and stimulates secretion of LH and relaxin
 - (2) Anterior pituitary gland and stimulates secretion of LH and oxytocin
 - (3) Anterior pituitary gland and stimulates secretion of LH and FSH
 - (4) Posterior pituitary gland and stimulates secretion of oxytocin and FSH

Answer (3)

Sol. Hypothalamus secretes GnRH which stimulates anterior pituitary gland for the secretion of gonadotropins (FSH and LH).

74. Which of the following facilitates opening of stomatal aperture?
- (1) Longitudinal orientation of cellulose microfibrils in the cell wall of guard cells
 - (2) Contraction of outer wall of guard cells
 - (3) Decrease in turgidity of guard cells
 - (4) Radial orientation of cellulose microfibrils in the cell wall of guard cells

Answer (4)

Sol. Cellulose microfibrils are oriented radially rather than longitudinally which makes easy for the stoma to open.

75. The genotypes of a Husband and Wife are $I^A I^B$ and $I^A i$. Among the blood types of their children, how many different genotypes and phenotypes are possible?
- (1) 4 genotypes ; 4 phenotypes
 - (2) 3 genotypes ; 3 phenotypes
 - (3) 3 genotypes ; 4 phenotypes
 - (4) 4 genotypes ; 3 phenotypes

Answer (4)

Sol. Husband \times Wife

♀	♂	I^A	I^B
I^A		$I^A I^A$	$I^A I^B$
i		$I^A i$	$I^B i$

Number of genotypes = 4
Number of phenotypes = 3
 $I^A I^A$ and $I^A i$ = A
 $I^A I^B$ = AB
 $I^B i$ = B

76. Plants which produce characteristic pneumatophores and show vivipary belong to
- (1) Hydrophytes
 - (2) Mesophytes
 - (3) Halophytes
 - (4) Psammophytes

Answer (3)

Sol. Halophytes growing in saline soils show

- (i) Vivipary which is *in-situ* seed germination
- (ii) Pneumatophores for gaseous exchange

77. Alexander Von Humboldt described for the first time
- (1) Population Growth equation
 - (2) Ecological Biodiversity
 - (3) Laws of limiting factor
 - (4) Species area relationships

Answer (4)

Sol. Alexander Von Humboldt observed that within a region species richness increases with the increases in area.

78. DNA replication in bacteria occurs
- (1) Just before transcription
 - (2) During S-phase
 - (3) Within nucleolus
 - (4) Prior to fission

Answer (4)

Sol. DNA replication in bacteria occurs prior to fission. Prokaryotes do not show well marked S-phase due to their primitive nature.

79. MALT constitutes about _____ percent of the lymphoid tissue in human body
- (1) 10%
 - (2) 50%
 - (3) 20%
 - (4) 70%

Answer (2)

Sol. MALT is Mucosa Associated Lymphoid Tissue and it constitutes about 50 percent of the lymphoid tissue in human body.

80. In *Bougainvillea* thorns are the modifications of
- (1) Leaf
 - (2) Stipules
 - (3) Adventitious root
 - (4) Stem

Answer (4)

Sol. Thorns are hard, pointed straight structures for protection. These are modified stem

81. Fruit and leaf drop at early stages can be prevented by the application of
- (1) Gibberellic acid
 - (2) Cytokinins
 - (3) Ethylene
 - (4) Auxins

Answer (4)

Sol. Auxins prevent premature leaf and fruit fall.

NAA prevents fruit drop in tomato; 2,4-D prevents fruit drop in *Citrus*.

82. Which of the following are found in extreme saline conditions?
- (1) Mycobacteria
 - (2) Archaeobacteria
 - (3) Eubacteria
 - (4) Cyanobacteria

Answer (2)

Sol. Archaeobacteria are able to survive in harsh conditions because of branched lipid chain in cell membrane which reduces fluidity of cell membrane.

Halophiles are exclusively found in saline habitats.

83. Coconut fruit is a
- (1) Capsule
 - (2) Drupe
 - (3) Berry
 - (4) Nut

Answer (2)

Sol. Coconut fruit is a drupe. A drupe develops from monocarpellary superior ovary and are one seeded.

84. The DNA fragments separated on an agarose gel can be visualised after staining with
- (1) Ethidium bromide
 - (2) Bromophenol blue
 - (3) Acetocarmine
 - (4) Aniline blue

Answer (1)

Sol. Ethidium bromide is used to stain the DNA fragments and will appear as orange coloured bands under UV light.

85. Out of 'X' pairs of ribs in humans only 'Y' pairs are true ribs. Select the option that correctly represents values of X and Y and provides their explanation :

- (1) X = 24, Y = 12 True ribs are dorsally attached to vertebral column but are free on ventral side
- (2) X = 12, Y = 7 True ribs are attached dorsally to vertebral column and ventrally to the sternum
- (3) X = 12, Y = 5 True ribs are attached dorsally to vertebral column and sternum on the two ends
- (4) X = 24, Y = 7 True ribs are dorsally attached to vertebral column but are free on ventral side

Answer (2)

Sol. In human, 12 pairs of ribs are present in which 7 pairs of ribs (1st to 7th pairs) are attached dorsally to vertebral column and ventrally to the sternum.

86. Myelin sheath is produced by

- (1) Osteoclasts and Astrocytes
- (2) Schwann Cells and Oligodendrocytes
- (3) Astrocytes and Schwann Cells
- (4) Oligodendrocytes and Osteoclasts

Answer (2)

Sol. Oligodendrocytes are neuroglial cells which produce myelin sheath in central nervous system while Schwann cell produces myelin sheath in peripheral nervous system.

87. Which of the following options gives the correct sequence of events during mitosis?

- (1) Condensation → arrangement at equator → centromere division → segregation → telophase
- (2) Condensation → nuclear membrane disassembly → crossing over → segregation → telophase
- (3) Condensation → nuclear membrane disassembly → arrangement at equator → centromere division → segregation → telophase
- (4) Condensation → crossing over → nuclear membrane disassembly → segregation → telophase

Answer (3)

Sol. The correct sequence of events during mitosis would be as follows

- (i) Condensation of DNA so that chromosomes become visible occurs during early to mid-prophase.
- (ii) Nuclear membrane disassembly begins at late prophase or transition to metaphase.
- (iii) Arrangement of chromosomes at equator occurs during metaphase, called congression.
- (iv) Centromere division or splitting occurs during anaphase forming daughter chromosomes.
- (v) Segregation also occurs during anaphase as daughter chromosomes separate and move to opposite poles.
- (vi) Telophase leads to formation of two daughter nuclei.

88. A disease caused by an autosomal primary non-disjunction is

- (1) Sickle cell anemia
- (2) Down's syndrome
- (3) Klinefelter's syndrome
- (4) Turner's syndrome

Answer (2)

Sol. Down's syndrome is caused by non-disjunction of 21st chromosome.

89. Which cells of 'Crypts of Lieberkuhn' secrete antibacterial lysozyme?

- (1) Kupffer cells (2) Argentaffin cells
- (3) Paneth cells (4) Zymogen cells

Answer (3)

Sol. – Kupffer-cells are phagocytic cells of liver.

– Zymogen cells are enzyme producing cells.

– Paneth cell secretes lysozyme which acts as anti-bacterial agent.

– Argentaffin cells are hormone producing cells.

90. Which one of the following is related to *Ex-situ* conservation of threatened animals and plants?

- (1) Himalayan region
- (2) Wildlife Safari parks
- (3) Biodiversity hot spots
- (4) Amazon rainforest

Answer (2)

Sol. *Ex-situ* conservation is offsite strategy for conservation of animals and plants in zoological park and botanical gardens respectively.

91. A spring of force constant k is cut into lengths of ratio 1 : 2 : 3. They are connected in series and the new force constant is k' . Then they are connected in parallel and force constant is k'' . Then $k' : k''$ is

- (1) 1 : 14
- (2) 1 : 6
- (3) 1 : 9
- (4) 1 : 11

Answer (4)

Sol. Spring constant $\propto \frac{1}{\text{length}}$

$$k \propto \frac{1}{l}$$

i.e, $k_1 = 6k$

$$k_2 = 3k$$

$$k_3 = 2k$$

In series

$$\frac{1}{k'} = \frac{1}{6k} + \frac{1}{3k} + \frac{1}{2k}$$

$$\frac{1}{k'} = \frac{6}{6k}$$

$$k' = k$$

$$k'' = 6k + 3k + 2k$$

$$k'' = 11k$$

$$\frac{k'}{k''} = \frac{1}{11} \quad \text{i.e } k' : k'' = 1 : 11$$

92. Thermodynamic processes are indicated in the following diagram.

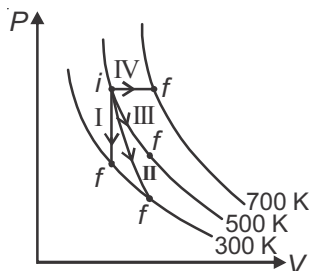

Match the following

Column-1

- P. Process I
- Q. Process II
- R. Process III
- S. Process IV

Column-2

- a. Adiabatic
- b. Isobaric
- c. Isochoric
- d. Isothermal

- (1) P → d, Q → b, R → a, S → c
- (2) P → a, Q → c, R → d, S → b
- (3) P → c, Q → a, R → d, S → b
- (4) P → c, Q → d, R → b, S → a

Answer (3)

Sol. Process I = Isochoric

II = Adiabatic

III = Isothermal

IV = Isobaric

93. A capacitor is charged by a battery. The battery is removed and another identical uncharged capacitor is connected in parallel. The total electrostatic energy of resulting system

- (1) Increases by a factor of 2
- (2) Increases by a factor of 4
- (3) Decreases by a factor of 2
- (4) Remains the same

Answer (3)

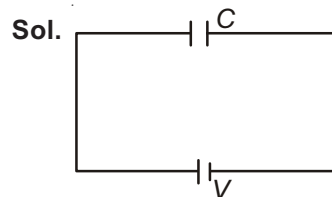

Charge on capacitor

$$q = CV$$

when it is connected with another uncharged capacitor.

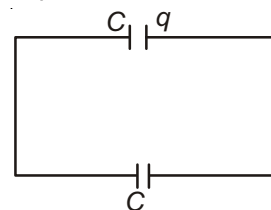

$$V_c = \frac{q_1 + q_2}{C_1 + C_2} = \frac{q + 0}{C + C}$$

$$V_c = \frac{V}{2}$$

Initial energy

$$U_i = \frac{1}{2} CV^2$$

Final energy

$$U_f = \frac{1}{2} C \left(\frac{V}{2}\right)^2 + \frac{1}{2} C \left(\frac{V}{2}\right)^2$$

$$= \frac{CV^2}{4}$$

Loss of energy = $U_i - U_f$

$$= \frac{CV^2}{4}$$

i.e. decreases by a factor (2)

94. A U tube with both ends open to the atmosphere, is partially filled with water. Oil, which is immiscible with water, is poured into one side until it stands at a distance of 10 mm above the water level on the other side. Meanwhile the water rises by 65 mm from its original level (see diagram). The density of the oil is

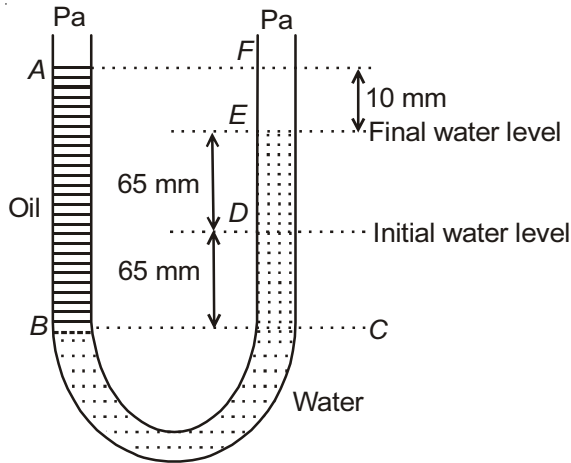

- (1) 928 kg m^{-3}
 (2) 650 kg m^{-3}
 (3) 425 kg m^{-3}
 (4) 800 kg m^{-3}

Answer (1)

Sol. $h_{\text{oil}} \rho_{\text{oil}} g = h_{\text{water}} \rho_{\text{water}} g$

$$140 \times \rho_{\text{oil}} = 130 \times \rho_{\text{water}}$$

$$\rho_{\text{oil}} = \frac{13}{14} \times 1000 \text{ kg/m}^3$$

$$\rho_{\text{oil}} = 928 \text{ kg m}^{-3}$$

95. The de-Broglie wavelength of a neutron in thermal equilibrium with heavy water at a temperature T (Kelvin) and mass m , is

(1) $\frac{2h}{\sqrt{mkT}}$

(2) $\frac{h}{\sqrt{mkT}}$

(3) $\frac{h}{\sqrt{3mkT}}$

(4) $\frac{2h}{\sqrt{3mkT}}$

Answer (3)

Sol. de-Broglie wavelength

$$\lambda = \frac{h}{mv}$$

$$= \frac{h}{\sqrt{2m(\text{KE})}}$$

$$= \frac{h}{\sqrt{2m\left(\frac{3}{2}kT\right)}}$$

$$\lambda = \frac{h}{\sqrt{3mkT}}$$

96. The acceleration due to gravity at a height 1 km above the earth is the same as at a depth d below the surface of earth. Then

(1) $d = 2 \text{ km}$

(2) $d = \frac{1}{2} \text{ km}$

(3) $d = 1 \text{ km}$

(4) $d = \frac{3}{2} \text{ km}$

Answer (1)

Sol. Above earth surface

Below earth surface

$$g' = g \left(1 - \frac{2h}{R_e}\right)$$

$$g' = g \left(1 - \frac{d}{R_e}\right)$$

$$\Delta g' = g \frac{2h}{R_e} \dots (1)$$

$$\Delta g = g \frac{d}{R_e} \dots (2)$$

From (1) & (2)

$$d = 2h$$

$$d = 2 \times 1 \text{ km}$$

97. The x and y coordinates of the particle at any time are $x = 5t - 2t^2$ and $y = 10t$ respectively, where x and y are in meters and t in seconds. The acceleration of the particle at $t = 2 \text{ s}$ is

(1) -8 m/s^2

(2) 0

(3) 5 m/s^2

(4) -4 m/s^2

Answer (4)

Sol. $x = 5t - 2t^2$

$y = 10t$

$$\frac{dx}{dt} = 5 - 4t$$

$$\frac{dy}{dt} = 10$$

$$v_x = 5 - 4t$$

$$v_y = 10$$

$$\frac{dv}{dt} x = -4$$

$$\frac{dv}{dt} y = 10$$

$$a_x = -4$$

$$a_y = 0$$

Acceleration of particle at $t = 2 \text{ s}$ is $= -4 \text{ m/s}^2$

98. In a common emitter transistor amplifier the audio signal voltage across the collector is 3 V. The resistance of collector is 3 kΩ. If current gain is 100 and the base resistance is 2 kΩ, the voltage and power gain of the amplifier is
- (1) 20 and 2000 (2) 200 and 1000
 (3) 15 and 200 (4) 150 and 15000

Answer (4)

Sol. Current gain (β) = 100

$$\begin{aligned} \text{Voltage gain } (A_v) &= \beta \frac{R_c}{R_b} \\ &= 100 \left(\frac{3}{2} \right) \\ &= 150 \end{aligned}$$

$$\begin{aligned} \text{Power gain} &= A_v \beta \\ &= 150 (100) \\ &= 15000 \end{aligned}$$

99. An arrangement of three parallel straight wires placed perpendicular to plane of paper carrying same current ' I ' along the same direction is shown in Fig. Magnitude of force per unit length on the middle wire 'B' is given by

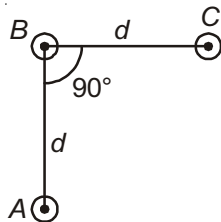

- (1) $\frac{\mu_0 I^2}{\sqrt{2}\pi d}$ (2) $\frac{\mu_0 I^2}{2\pi d}$
 (3) $\frac{2\mu_0 I^2}{\pi d}$ (4) $\frac{\sqrt{2}\mu_0 I^2}{\pi d}$

Answer (1)

Sol. Force between BC and AB will be same in magnitude.

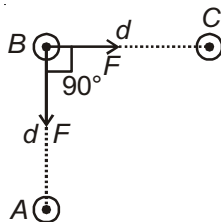

$$\begin{aligned} F_{BC} &= F_{BA} = \frac{\mu_0 I^2}{2\pi d} \\ F &= \sqrt{2} F_{BC} \\ &= \sqrt{2} \frac{\mu_0 I^2}{2\pi d} \\ F &= \frac{\mu_0 I^2}{\sqrt{2}\pi d} \end{aligned}$$

100. Two astronauts are floating in gravitational free space after having lost contact with their spaceship. The two will:
- (1) Will become stationary
 (2) Keep floating at the same distance between them
 (3) Move towards each other
 (4) Move away from each other

Answer (3)

Sol. Both the astronauts are in the condition of weightness. Gravitational force between them pulls towards each other.

101. A Carnot engine having an efficiency of $\frac{1}{10}$ as heat engine, is used as a refrigerator. If the work done on the system is 10 J, the amount of energy absorbed from the reservoir at lower temperature is
- (1) 100 J (2) 1 J
 (3) 90 J (4) 99 J

Answer (3)

$$\begin{aligned} \text{Sol. } \beta &= \frac{1-\eta}{\eta} \\ &= \frac{1-\frac{1}{10}}{\frac{1}{10}} = \frac{9}{1} \end{aligned}$$

$$\beta = 9$$

$$\beta = \frac{Q_2}{W}$$

$$Q_2 = 9 \times 10 = 90 \text{ J}$$

102. A 250-Turn rectangular coil of length 2.1 cm and width 1.25 cm carries a current of 85 μA and subjected to a magnetic field of strength 0.85 T. Work done for rotating the coil by 180° against the torque is
- (1) 1.15 μJ (2) 9.1 μJ
 (3) 4.55 μJ (4) 2.3 μJ

Answer (2)

Sol. $W = MB (\cos\theta_1 - \cos\theta_2)$

When it is rotated by angle 180° then



$$W = 2MB$$

$$W = 2 (NIA)B$$

$$= 2 \times 250 \times 85 \times 10^{-6} [1.25 \times 2.1 \times 10^{-4}] \times 85 \times 10^{-2}$$

$$= 9.1 \mu\text{J}$$

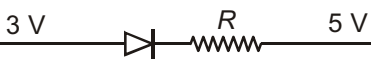
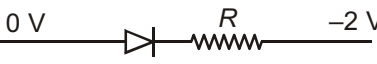
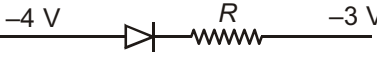
103. Which one of the following represents forward bias diode?

- (1) 
- (2) 
- (3) 
- (4) 

Answer (2)

Sol. In forward bias, p -type semiconductor is at higher potential w.r.t. n -type semiconductor.

104. The ratio of wavelengths of the last line of Balmer series and the last line of Lyman series is

- (1) 0.5 (2) 2
 (3) 1 (4) 4

Answer (4)

Sol. For last Balmer series

$$\frac{1}{\lambda_b} = R \left[\frac{1}{2^2} - \frac{1}{\infty^2} \right]$$

$$\lambda_b = \frac{4}{R}$$

For last Lyman series

$$\frac{1}{\lambda_l} = R \left[\frac{1}{1^2} - \frac{1}{\infty^2} \right]$$

$$\lambda_l = \frac{1}{R}$$

$$\frac{\lambda_b}{\lambda_l} = \frac{4}{1/R} = \frac{4R}{1} = 4$$

$$\frac{\lambda_b}{\lambda_l} = 4$$

105. Figure shows a circuit contains three identical resistors with resistance $R = 9.0 \Omega$ each, two identical inductors with inductance $L = 2.0 \text{ mH}$ each, and an ideal battery with emf $\varepsilon = 18 \text{ V}$. The current 'i' through the battery just after the switch closed is

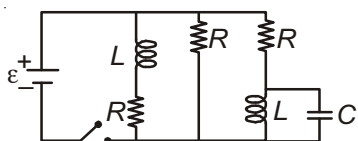

- (1) 0 ampere (2) 2 mA
 (3) 0.2 A (4) 2 A

Answer (4*)

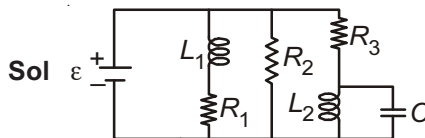

At $t = 0$, no current flows through R_1 and R_3

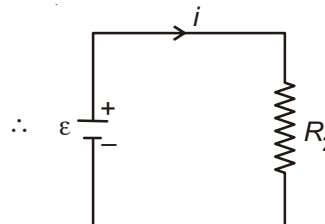

$$i = \frac{\varepsilon}{R_2}$$

$$= \frac{18}{9}$$

$$= 2 \text{ A}$$

Note : Not correctly framed but the best option out of given is (4).

106. Two blocks A and B of masses $3m$ and m respectively are connected by a massless and inextensible string. The whole system is suspended by a massless spring as shown in figure. The magnitudes of acceleration of A and B immediately after the string is cut, are respectively

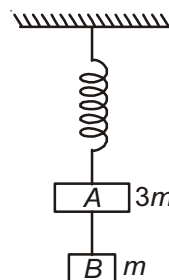

- (1) $\frac{g}{3}, \frac{g}{3}$ (2) $g, \frac{g}{3}$
 (3) $\frac{g}{3}, g$ (4) g, g

Answer (3)

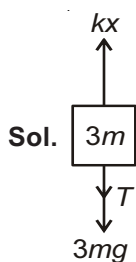

Before the string is cut

$$kx = T + 3mg \quad \dots(1)$$

$$T = mg \quad \dots(2)$$



$$\Rightarrow kx = 4mg$$

After the string is cut, $T = 0$

$$a = \frac{kx - 3mg}{3m}$$

$$a = \frac{4mg - 3mg}{3m}$$

$$a = \frac{g}{3} \uparrow$$

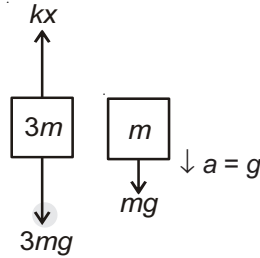

107. A long solenoid of diameter 0.1 m has 2×10^4 turns per meter. At the centre of the solenoid, a coil of 100 turns and radius 0.01 m is placed with its axis coinciding with the solenoid axis. The current in the solenoid reduces at a constant rate to 0 A from 4 A in 0.05 s. If the resistance of the coil is $10\pi^2 \Omega$, the total charge flowing through the coil during this time is

- (1) $16\pi \mu\text{C}$ (2) $32\pi \mu\text{C}$
 (3) $16 \mu\text{C}$ (4) $32 \mu\text{C}$

Answer (4)

Sol. $\varepsilon = -N \frac{d\phi}{dt}$

$$\left| \frac{\varepsilon}{R} \right| = \frac{N}{R} \frac{d\phi}{dt}$$

$$dq = \frac{N}{R} d\phi$$

$$\Delta Q = \frac{N(\Delta\phi)}{R}$$

$$\Delta Q = \frac{\Delta\phi_{\text{total}}}{R}$$

$$= \frac{(NBA)}{R}$$

$$= \frac{\mu_0 n i \pi r^2}{R}$$

Putting values

$$= \frac{4\pi \times 10^{-7} \times 100 \times 4 \times \pi \times (0.01)^2}{10\pi^2}$$

$$\Delta Q = 32 \mu\text{C}$$

108. A physical quantity of the dimensions of length that can be formed out of c , G and $\frac{e^2}{4\pi\epsilon_0}$ is [c is velocity of light, G is universal constant of gravitation and e is charge]

- (1) $\frac{1}{c} G \frac{e^2}{4\pi\epsilon_0}$ (2) $\frac{1}{c^2} \left[G \frac{e^2}{4\pi\epsilon_0} \right]^{\frac{1}{2}}$
 (3) $c^2 \left[G \frac{e^2}{4\pi\epsilon_0} \right]^{\frac{1}{2}}$ (4) $\frac{1}{c^2} \left[\frac{e^2}{G4\pi\epsilon_0} \right]^{\frac{1}{2}}$

Answer (2)

Sol. Let $\frac{e^2}{4\pi\epsilon_0} = A = ML^3T^{-2}$

$$l = C^x G^y (A)^z$$

$$L = [LT^{-1}]^x [M^{-1}L^3T^{-2}]^y [ML^3T^{-2}]^z$$

$$-y + z = 0 \Rightarrow y = z \quad \dots(i)$$

$$x + 3y + 3z = 1 \quad \dots(ii)$$

$$-x - 4z = 0 \quad \dots(iii)$$

From (i), (ii) & (iii)

$$z = y = \frac{1}{2}, \quad x = -2$$

109. In an electromagnetic wave in free space the root mean square value of the electric field is $E_{\text{rms}} = 6 \text{ V/m}$. The peak value of the magnetic field is

- (1) $4.23 \times 10^{-8} \text{ T}$
 (2) $1.41 \times 10^{-8} \text{ T}$
 (3) $2.83 \times 10^{-8} \text{ T}$
 (4) $0.70 \times 10^{-8} \text{ T}$

Answer (3)

Sol. $\frac{E_{\text{rms}}}{B_{\text{rms}}} = c$

$$B_{\text{rms}} = \frac{E_{\text{rms}}}{c}$$

$$= \frac{6}{3 \times 10^8}$$

$$B_{\text{rms}} = 2 \times 10^{-8}$$

$$B_{\text{rms}} = \frac{B_0}{\sqrt{2}}$$

$$B_0 = \sqrt{2} \times B_{\text{rms}}$$

$$= \sqrt{2} \times 2 \times 10^{-8}$$

$$= 2.83 \times 10^{-8} \text{ T}$$

110. The resistance of a wire is 'R' ohm. If it is melted and stretched to 'n' times its original length, its new resistance will be

- (1) $\frac{R}{n^2}$ (2) nR
- (3) $\frac{R}{n}$ (4) n^2R

Answer (4)

Sol. $\frac{R_2}{R_1} = \frac{l_2^2}{l_1^2}$

$$= \frac{n^2 l_1^2}{l_1^2}$$

$$\frac{R_2}{R_1} = n^2$$

$$R_2 = n^2 R_1$$

111. The ratio of resolving powers of an optical microscope for two wavelengths $\lambda_1 = 4000 \text{ \AA}$ and $\lambda_2 = 6000 \text{ \AA}$ is

- (1) 16 : 81 (2) 8 : 27
- (3) 9 : 4 (4) 3 : 2

Answer (4)

Sol. Resolving power $\propto \frac{1}{\lambda}$

$$\frac{R_1}{R_2} = \frac{\lambda_2}{\lambda_1}$$

$$= \frac{6000 \text{ \AA}}{4000 \text{ \AA}}$$

$$= \frac{3}{2}$$

112. A thin prism having refracting angle 10° is made of glass of refractive index 1.42. This prism is combined with another thin prism of glass of refractive index 1.7. This combination produces dispersion without deviation. The refracting angle of second prism should be

- (1) 10° (2) 4°
- (3) 6° (4) 8°

Answer (3)

Sol. $(\mu - 1)A + (\mu' - 1)A' = 0$

$$|(\mu - 1)A| = |(\mu' - 1)A'|$$

$$(1.42 - 1) \times 10^\circ = (1.7 - 1)A'$$

$$4.2 = 0.7A'$$

$$A' = 6^\circ$$

113. Two Polaroids P_1 and P_2 are placed with their axis perpendicular to each other. Unpolarised light I_0 is incident on P_1 . A third polaroid P_3 is kept in between P_1 and P_2 such that its axis makes an angle 45° with that of P_1 . The intensity of transmitted light through P_2 is

- (1) $\frac{I_0}{16}$ (2) $\frac{I_0}{2}$
- (3) $\frac{I_0}{4}$ (4) $\frac{I_0}{8}$

Answer (4)

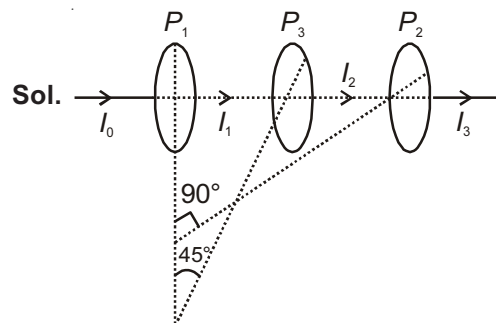

$$I_2 = \frac{I_0}{2} \cos^2 45^\circ$$

$$= \frac{I_0}{2} \times \frac{1}{2}$$

$$= \frac{I_0}{4}$$

$$I_3 = \frac{I_0}{4} \cos^2 45^\circ$$

$$I_3 = \frac{I_0}{8}$$

114. A potentiometer is an accurate and versatile device to make electrical measurements of E.M.F, because the method involves :

- (1) A combination of cells, galvanometer and resistances
- (2) Cells
- (3) Potential gradients
- (4) A condition of no current flow through the galvanometer

Answer (4)

Sol. Reading of potentiometer is accurate because during taking reading it does not draw any current from the circuit.

115. The two nearest harmonics of a tube closed at one end and open at other end are 220 Hz and 260 Hz. What is the fundamental frequency of the system?

- (1) 40 Hz
- (2) 10 Hz
- (3) 20 Hz
- (4) 30 Hz

Answer (3)

Sol. Two successive frequencies of closed pipe

$$\frac{nv}{4l} = 220 \quad \dots(i)$$

$$\frac{(n+2)v}{4l} = 260 \quad \dots(ii)$$

Dividing (ii) by (i), we get

$$\frac{n+2}{n} = \frac{260}{220} = \frac{13}{11}$$

$$11n + 22 = 13n$$

$$n = 11$$

$$\text{So, } 11 \frac{v}{4l} = 220$$

$$\frac{v}{4l} = 20$$

So fundamental frequency is 20 Hz.

116. A beam of light from a source L is incident normally on a plane mirror fixed at a certain distance x from the source. The beam is reflected back as a spot on a scale placed just above the source L . When the mirror is rotated through a small angle θ , the spot of the light is found to move through a distance y on the scale. The angle θ is given by

- (1) $\frac{x}{y}$
- (2) $\frac{y}{2x}$
- (3) $\frac{y}{x}$
- (4) $\frac{x}{2y}$

Answer (2)

Sol. When mirror is rotated by θ angle reflected ray will be rotated by 2θ .

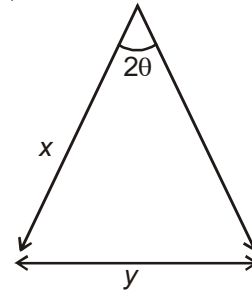

$$\frac{y}{x} = 2\theta$$

$$\theta = \frac{y}{2x}$$

117. The given electrical network is equivalent to

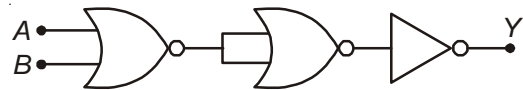

- (1) NOT gate
- (2) AND gate
- (3) OR gate
- (4) NOR gate

Answer (4)

Sol. $Y = A + B$

118. A particle executes linear simple harmonic motion with an amplitude of 3 cm. When the particle is at 2 cm from the mean position, the magnitude of its velocity is equal to that of its acceleration. Then its time period in seconds is

- (1) $\frac{2\pi}{\sqrt{3}}$
- (2) $\frac{\sqrt{5}}{\pi}$
- (3) $\frac{\sqrt{5}}{2\pi}$
- (4) $\frac{4\pi}{\sqrt{5}}$

Answer (4)

Sol. $v = \omega\sqrt{A^2 - x^2}$

$$a = x\omega^2$$

$$v = a$$

$$\omega\sqrt{A^2 - x^2} = x\omega^2$$

$$\sqrt{(3)^2 - (2)^2} = 2\left(\frac{2\pi}{T}\right)$$

$$\sqrt{5} = \frac{4\pi}{T}$$

$$T = \frac{4\pi}{\sqrt{5}}$$

Answer (2)

Sol. Centripetal force $\left(\frac{mv^2}{l}\right)$ is provided by tension so the net force will be equal to tension *i.e.*, T .

124. A rope is wound around a hollow cylinder of mass 3 kg and radius 40 cm. What is the angular acceleration of the cylinder if the rope is pulled with a force of 30 N?

- (1) 5 m/s² (2) 25 m/s²
 (3) 0.25 rad/s² (4) 25 rad/s²

Answer (4)

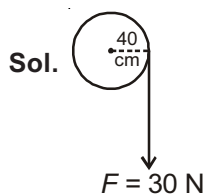

$$\tau = I \alpha$$

$$F \times R = MR^2 \alpha$$

$$30 \times 0.4 = 3 \times (0.4)^2 \alpha$$

$$12 = 3 \times 0.16 \alpha$$

$$400 = 16 \alpha$$

$$\alpha = 25 \text{ rad/s}^2$$

125. Young's double slit experiment is first performed in air and then in a medium other than air. It is found that 8th bright fringe in the medium lies where 5th dark fringe lies in air. The refractive index of the medium is nearly

- (1) 1.78 (2) 1.25
 (3) 1.59 (4) 1.69

Answer (1)

Sol. $X_1 = X_{5^{\text{th dark}}} = (2 \times 5 - 1) \frac{\lambda D}{2d}$

$$X_2 = X_{8^{\text{th bright}}} = 8 \frac{\lambda D}{\mu d}$$

$$X_1 = X_2$$

$$\frac{9 \lambda D}{2 d} = 8 \frac{\lambda D}{\mu d}$$

$$\mu = \frac{16}{9} = 1.78$$

126. Suppose the charge of a proton and an electron differ slightly. One of them is $-e$, the other is $(e + \Delta e)$. If the net of electrostatic force and gravitational force between two hydrogen atoms placed at a distance d (much greater than atomic size) apart is zero, then Δe is of the order of [Given mass of hydrogen $m_h = 1.67 \times 10^{-27}$ kg]

- (1) 10^{-47} C (2) 10^{-20} C
 (3) 10^{-23} C (4) 10^{-37} C

Answer (4)

Sol. $F_e = F_g$

$$\frac{1}{4\pi\epsilon_0} \frac{\Delta e^2}{d^2} = \frac{Gm^2}{d^2}$$

$$9 \times 10^9 (\Delta e^2) = 6.67 \times 10^{-11} \times 1.67 \times 10^{-27} \times 1.67 \times 10^{-27}$$

$$\Delta e^2 = \frac{6.67 \times 1.67 \times 1.67}{9} \times 10^{-74}$$

$$\Delta e \approx 10^{-37}$$

127. Two rods A and B of different materials are welded together as shown in figure. Their thermal conductivities are K_1 and K_2 . The thermal conductivity of the composite rod will be

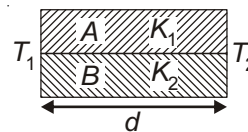

- (1) $2(K_1 + K_2)$
 (2) $\frac{K_1 + K_2}{2}$
 (3) $\frac{3(K_1 + K_2)}{2}$
 (4) $K_1 + K_2$

Answer (2)

Sol. Thermal current

$$H = H_1 + H_2$$

$$= \frac{K_1 A (T_1 - T_2)}{d} + \frac{K_2 A (T_1 - T_2)}{d}$$

$$\frac{K_{EQ} 2A (T_1 - T_2)}{d} = \frac{A (T_1 - T_2)}{d} [K_1 + K_2]$$

$$K_{EQ} = \left[\frac{K_1 + K_2}{2} \right]$$

128. The photoelectric threshold wavelength of silver is 3250×10^{-10} m. The velocity of the electron ejected from a silver surface by ultraviolet light of wavelength 2536×10^{-10} m is

(Given $h = 4.14 \times 10^{-15}$ eVs and $c = 3 \times 10^8$ ms⁻¹)

(1) $\approx 0.3 \times 10^6$ ms⁻¹

(2) $\approx 6 \times 10^5$ ms⁻¹

(3) $\approx 0.6 \times 10^6$ ms⁻¹

(4) $\approx 61 \times 10^3$ ms⁻¹

Answer (2 & 3)* Both answers are correct.

Sol. $\lambda_0 = 3250 \times 10^{-10}$ m

$\lambda = 2536 \times 10^{-10}$ m

$\phi = \frac{1242 \text{ eV-nm}}{325 \text{ nm}} = 3.82 \text{ eV}$

$h\nu = \frac{1242 \text{ eV-nm}}{253.6 \text{ nm}} = 4.89 \text{ eV}$

$KE_{\text{max}} = (4.89 - 3.82) \text{ eV} = 1.077 \text{ eV}$

$\frac{1}{2}mv^2 = 1.077 \times 1.6 \times 10^{-19}$

$v = \sqrt{\frac{2 \times 1.077 \times 1.6 \times 10^{-19}}{9.1 \times 10^{-31}}}$

$v = 0.6 \times 10^6$ m/s

129. Two cars moving in opposite directions approach each other with speed of 22 m/s and 16.5 m/s respectively. The driver of the first car blows a horn having a frequency 400 Hz. The frequency heard by the driver of the second car is [velocity of sound 340 m/s]

(1) 448 Hz (2) 350 Hz

(3) 361 Hz (4) 411 Hz

Answer (1)

Sol. $f_A = f \left[\frac{v + v_o}{v - v_s} \right]$

$= 400 \left[\frac{340 + 16.5}{340 - 22} \right]$

$f_A = 448 \text{ Hz}$

130. Consider a drop of rain water having mass 1 g falling from a height of 1 km. It hits the ground with a speed of 50 m/s. Take g constant with a value 10 m/s². The work done by the (i) gravitational force and the (ii) resistive force of air is

(1) (i) 10 J (ii) -8.75 J

(2) (i) -10 J (ii) -8.25 J

(3) (i) 1.25 J (ii) -8.25 J

(4) (i) 100 J (ii) 8.75 J

Answer (1)

Sol. $w_g + w_a = K_f - K_i$

$mgh + w_a = \frac{1}{2}mv^2 - 0$

$10^{-3} \times 10 \times 10^3 + w_a = \frac{1}{2} \times 10^{-3} \times (50)^2$

$w_a = -8.75$ J i.e. work done due to air resistance and work done due to gravity = 10 J

131. A spherical black body with a radius of 12 cm radiates 450 watt power at 500 K. If the radius were halved and the temperature doubled, the power radiated in watt would be

(1) 1800

(2) 225

(3) 450

(4) 1000

Answer (1)

Sol. Rate of power loss

$r \propto R^2 T^4$

$\frac{r_1}{r_2} = \frac{R_1^2 T_1^4}{R_2^2 T_2^4}$

$= 4 \times \frac{1}{16}$

$\frac{450}{r_2} = \frac{1}{4}$

$r_2 = 1800$ watt

132. The diagrams below show regions of equipotentials.

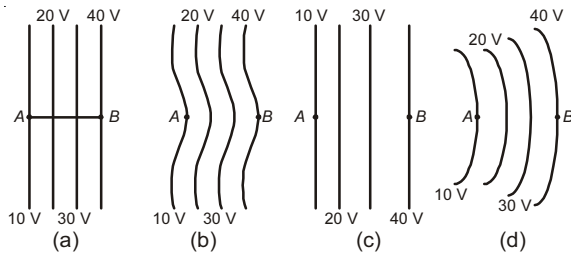

A positive charge is moved from A to B in each diagram.

- (1) Maximum work is required to move q in figure (b).
- (2) Maximum work is required to move q in figure (c).
- (3) In all the four cases the work done is the same.
- (4) Minimum work is required to move q in figure (a).

Answer (3)

Sol. Work done $w = q\Delta V$

ΔV is same in all the cases so work is done will be same in all the cases.

133. Which of the following statements are correct?

- (a) Centre of mass of a body always coincides with the centre of gravity of the body.
- (b) Centre of mass of a body is the point at which the total gravitational torque on the body is zero
- (c) A couple on a body produce both translational and rotational motion in a body.
- (d) Mechanical advantage greater than one means that small effort can be used to lift a large load.

- (1) (c) and (d)
- (2) (b) and (d)
- (3) (a) and (b)
- (4) (b) and (c)

Answer (2)

Sol. Centre of mass may or may not coincide with centre of gravity.

134. If θ_1 and θ_2 be the apparent angles of dip observed in two vertical planes at right angles to each other, then the true angle of dip θ is given by

- (1) $\tan^2\theta = \tan^2\theta_1 - \tan^2\theta_2$
- (2) $\cot^2\theta = \cot^2\theta_1 + \cot^2\theta_2$
- (3) $\tan^2\theta = \tan^2\theta_1 + \tan^2\theta_2$
- (4) $\cot^2\theta = \cot^2\theta_1 - \cot^2\theta_2$

Answer (2)

Sol. $\cot^2\theta = \cot^2\theta_1 + \cot^2\theta_2$

135. Radioactive material 'A' has decay constant ' 8λ ' and material 'B' has decay constant ' λ '. Initially they have same number of nuclei. After what time, the ratio of number of nuclei of material 'B' to that 'A' will

be $\frac{1}{e}$?

- (1) $\frac{1}{9\lambda}$
- (2) $\frac{1}{\lambda}$
- (3) $\frac{1}{7\lambda}$
- (4) $\frac{1}{8\lambda}$

Answer (3)

Sol. No option is correct

If we take $\frac{N_A}{N_B} = \frac{1}{e}$

Then

$$\frac{N_A}{N_B} = \frac{e^{-8\lambda t}}{e^{-\lambda t}}$$

$$\frac{1}{e} = e^{-7\lambda t}$$

$$-1 = -7\lambda t$$

$$t = \frac{1}{7\lambda}$$

136. The equilibrium constants of the following are.

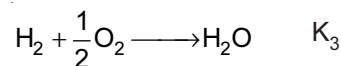
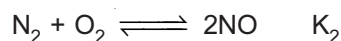
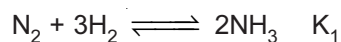

The equilibrium constant (K) of the reaction

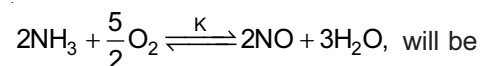

Answer (3)

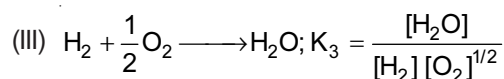
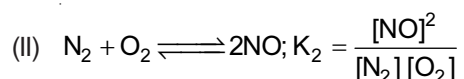
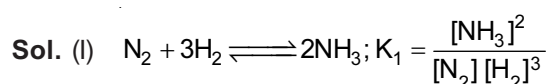

(II + 3 × III - I) will give

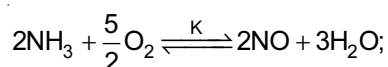

$$\therefore K = K_2 \times K_3^3 / K_1$$

137. The heating of phenyl-methyl ethers with HI produces.

- (1) Benzene (2) Ethyl chlorides
(3) Iodobenzene (4) Phenol

Answer (4)

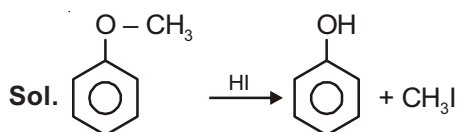

138. The most suitable method of separation of 1 : 1 mixture of ortho and para-nitrophenols is

- (1) Steam distillation (2) Sublimation
(3) Chromatography (4) Crystallisation

Answer (1)

Sol. Steam distillation is the most suitable method of separation of 1 : 1 mixture of ortho and para nitrophenols as there is intramolecular H-bonds in ortho nitrophenol.

139. Predict the correct intermediate and product in the following reaction

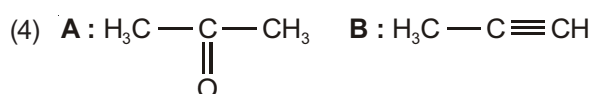
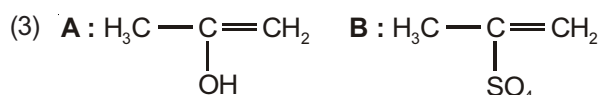
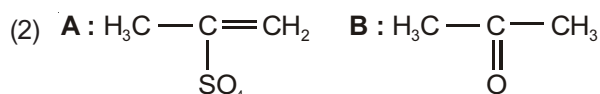
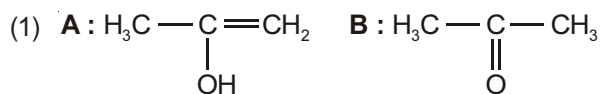
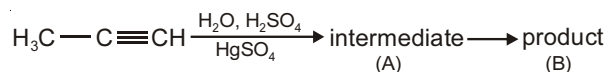

Answer (1)

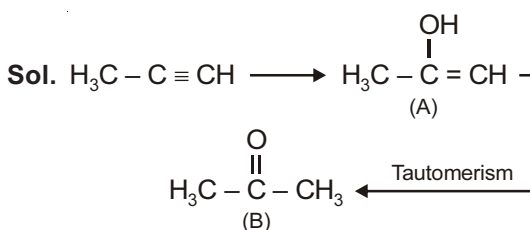

140. Which of the following reactions is appropriate for converting acetamide to methanamine?

- (1) Gabriel's phthalimide synthesis
(2) Carbylamine reaction
(3) Hoffmann hypobromamide reaction
(4) Stephens reaction

Answer (3)

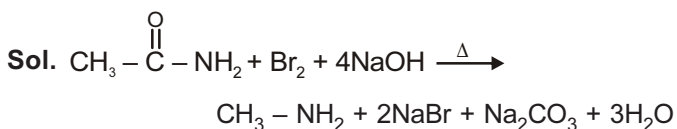

This is Hoffmann Bromamide reaction.

141. The IUPAC name of the compound

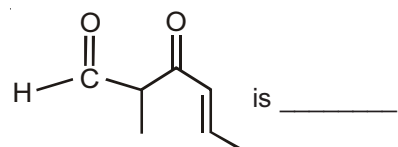

- (1) 3-keto-2-methylhex-5-enal
(2) 3-keto-2-methylhex-4-enal
(3) 5-formylhex-2-en-3-one
(4) 5-methyl-4-oxohex-2-en-5-al

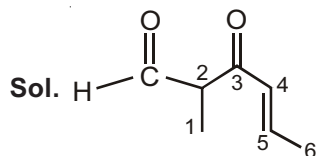
Answer (2)

Aldehydes get higher priority over ketone and alkene in numbering of principal C-chain.

∴ 3-keto-2-methylhex-4-enal

142. Which of the following is a sink for CO?

- (1) Plants
- (2) Haemoglobin
- (3) Micro-organisms present in the soil
- (4) Oceans

Answer (3)

Sol. Micro-organisms present in the soil is a sink for CO.

143. Of the following, which is the product formed when cyclohexanone undergoes aldol condensation followed by heating?

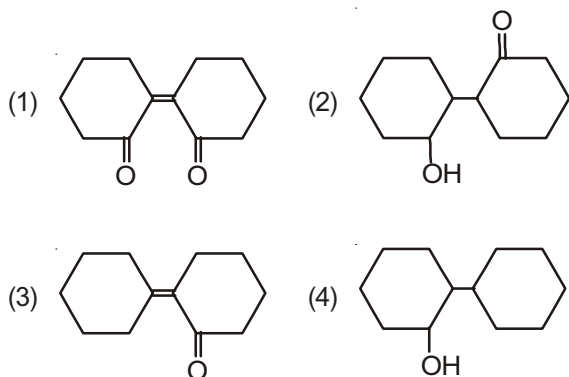
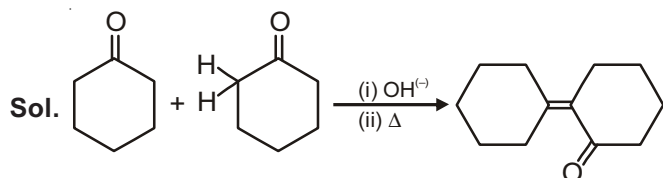
**Answer (3)**

144. Which of the following pairs of compounds is isoelectronic and isostructural?

- (1) IF_3 , XeF_2
- (2) BeCl_2 , XeF_2
- (3) TeI_2 , XeF_2
- (4) IBr_2^- , XeF_2

Answer (4)

Sol. IBr_2^- , XeF_2

Total number of valence electrons are equal in both the species and both the species are linear also.

145. Consider the reactions :

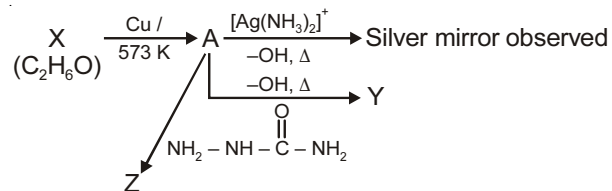

Identify A, X, Y and Z

- (1) A-Ethanol, X-Acetaldehyde, Y-Butanone, Z-Hydrazone
- (2) A-Methoxymethane, X-Ethanoic acid, Y-Acetate ion, Z-hydrazine
- (3) A-Methoxymethane, X-Ethanol, Y-Ethanoic acid, Z-Semicarbazide
- (4) A-Ethanal, X-Ethanol, Y-But-2-enal, Z-Semicarbazone

Answer (4)

Sol. Since 'A' gives positive silver mirror test therefore, it must be an aldehyde or α -Hydroxyketone.

Reaction with semicarbazide indicates that A can be an aldehyde or ketone.

Reaction with OH^- i.e., aldol condensation (by assuming alkali to be dilute) indicates that A is aldehyde as aldol reaction of ketones is reversible and carried out in special apparatus.

These indicates option (4).

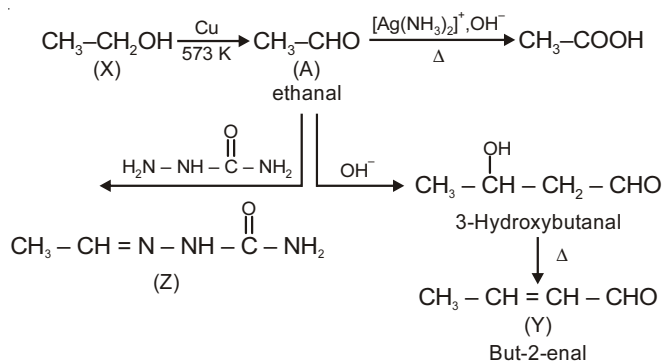

146. Which one is the most acidic compound?

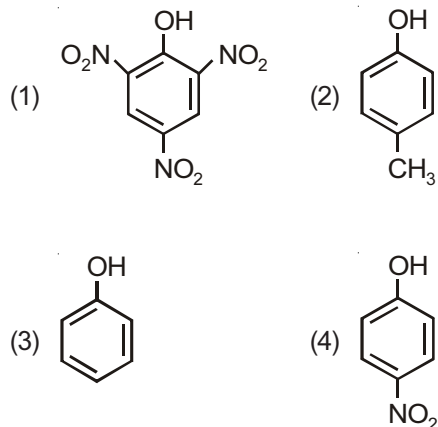

Answer (1)

Sol. $-\text{NO}_2$ group has very strong $-I$ & $-R$ effects.

147. Name the gas that can readily decolourises acidified KMnO_4 solution:

- (1) P_2O_5 (2) CO_2
 (3) SO_2 (4) NO_2

Answer (3)

Sol. SO_2 is readily decolourises acidified KMnO_4 .

148. Which one is the **correct** order of acidity?

- (1) $\text{CH}_3 - \text{CH}_3 > \text{CH}_2 = \text{CH}_2 > \text{CH}_3 - \text{C} \equiv \text{CH} > \text{CH} \equiv \text{CH}$
 (2) $\text{CH}_2 = \text{CH}_2 > \text{CH}_3 - \text{CH} = \text{CH}_2 > \text{CH}_3 - \text{C} \equiv \text{CH} > \text{CH} \equiv \text{CH}$
 (3) $\text{CH} \equiv \text{CH} > \text{CH}_3 - \text{C} \equiv \text{CH} > \text{CH}_2 = \text{CH}_2 > \text{CH}_3 - \text{CH}_3$
 (4) $\text{CH} \equiv \text{CH} > \text{CH}_2 = \text{CH}_2 > \text{CH}_3 - \text{C} \equiv \text{CH} > \text{CH}_3 - \text{CH}_3$

Answer (3)

Sol. Correct order is

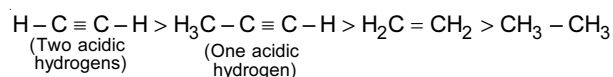

149. Concentration of the Ag^+ ions in a saturated solution of $\text{Ag}_2\text{C}_2\text{O}_4$ is $2.2 \times 10^{-4} \text{ mol L}^{-1}$. Solubility product of $\text{Ag}_2\text{C}_2\text{O}_4$ is

- (1) 5.3×10^{-12} (2) 2.42×10^{-8}
 (3) 2.66×10^{-12} (4) 4.5×10^{-11}

Answer (1)

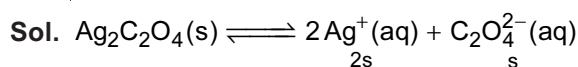

$$K_{\text{SP}} = [\text{Ag}^+]^2 [\text{C}_2\text{O}_4^{2-}]$$

$$[\text{Ag}^+] = 2.2 \times 10^{-4} \text{ M}$$

$$\therefore [\text{C}_2\text{O}_4^{2-}] = \frac{2.2 \times 10^{-4}}{2} \text{ M} = 1.1 \times 10^{-4} \text{ M}$$

$$\therefore K_{\text{SP}} = (2.2 \times 10^{-4})^2 (1.1 \times 10^{-4}) = 5.324 \times 10^{-12}$$

150. With respect to the conformers of ethane, which of the following statements is true?

- (1) Both bond angles and bond length remains same
 (2) Bond angle remains same but bond length changes
 (3) Bond angle changes but bond length remains same
 (4) Both bond angle and bond length change

Answer (1)

Sol. There is no change in bond angles and bond lengths in the conformations of ethane. There is only change in dihedral angle.

151. The correct statement regarding electrophile is

- (1) Electrophile can be either neutral or positively charged species and can form a bond by accepting a pair of electrons from a nucleophile
 (2) Electrophile is a negatively charged species and can form a bond by accepting a pair of electrons from a nucleophile
 (3) Electrophile is a negatively charged species and can form a bond by accepting a pair of electrons from another electrophile
 (4) Electrophiles are generally neutral species and can form a bond by accepting a pair of electrons from a nucleophile

Answer (1)

Sol. Fact.

152. Which one is the wrong statement?

- (1) The energy of 2s orbital is less than the energy of 2p orbital in case of Hydrogen like atoms
 (2) de-Broglie's wavelength is given by $\lambda = \frac{h}{mv}$, where m = mass of the particle, v = group velocity of the particle
 (3) The uncertainty principle is $\Delta E \times \Delta t \geq \frac{h}{4\pi}$
 (4) Half-filled and fully filled orbitals have greater stability due to greater exchange energy, greater symmetry and more balanced arrangement

Answer (1)

Sol. Energy of 2s-orbital and 2p-orbital in case of hydrogen like atoms is equal.

153. Correct increasing order for the wavelengths of absorption in the visible region for the complexes of Co^{3+} is

- (1) $[\text{Co}(\text{NH}_3)_6]^{3+}$, $[\text{Co}(\text{en})_3]^{3+}$, $[\text{Co}(\text{H}_2\text{O})_6]^{3+}$
- (2) $[\text{Co}(\text{en})_3]^{3+}$, $[\text{Co}(\text{NH}_3)_6]^{3+}$, $[\text{Co}(\text{H}_2\text{O})_6]^{3+}$
- (3) $[\text{Co}(\text{H}_2\text{O})_6]^{3+}$, $[\text{Co}(\text{en})_3]^{3+}$, $[\text{Co}(\text{NH}_3)_6]^{3+}$
- (4) $[\text{Co}(\text{H}_2\text{O})_6]^{3+}$, $[\text{Co}(\text{NH}_3)_6]^{3+}$, $[\text{Co}(\text{en})_3]^{3+}$

Answer (2)

Sol. The order of the ligand in the spectrochemical series



Hence, the wavelength of the light observed will be in the order

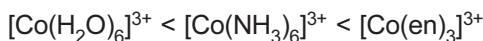

Thus, wavelength absorbed will be in the opposite order

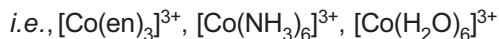

154. Match the interhalogen compounds of column I with the geometry in column II and assign the correct code

Column I	Column II
(a) XX'	(i) T-shape
(b) XX'_3	(ii) Pentagonal bipyramidal
(c) XX'_5	(iii) Linear
(d) XX'_7	(iv) Square-pyramidal
	(v) Tetrahedral

Code :

	(a)	(b)	(c)	(d)
(1)	(iv)	(iii)	(ii)	(i)
(2)	(iii)	(iv)	(i)	(ii)
(3)	(iii)	(i)	(iv)	(ii)
(4)	(v)	(iv)	(iii)	(ii)

Answer (3)

Sol. $\text{XX}' \rightarrow$ Linear

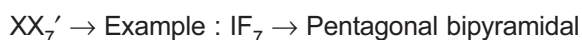
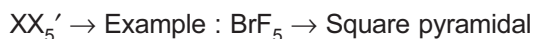
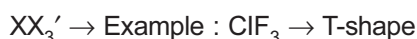

155. The species, having bond angles of 120° is

- (1) BCl_3
- (2) PH_3
- (3) ClF_3
- (4) NCl_3

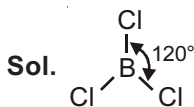
Answer (1)

156. The correct increasing order of basic strength for the following compounds is

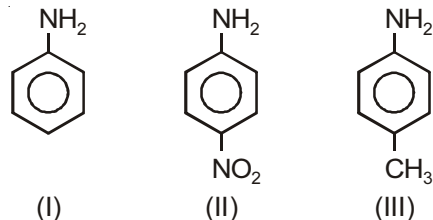

- (1) $\text{II} < \text{I} < \text{III}$
- (2) $\text{II} < \text{III} < \text{I}$
- (3) $\text{III} < \text{I} < \text{II}$
- (4) $\text{III} < \text{II} < \text{I}$

Answer (1)

Sol. $-\text{NO}_2$ has strong $-\text{R}$ effect and $-\text{CH}_3$ shows $+\text{R}$ effect.

\therefore Order of basic strength is

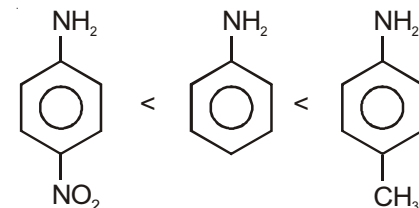

Which one of the following statements is not correct?

- (1) Coenzymes increase the catalytic activity of enzyme
- (2) Catalyst does not initiate any reaction
- (3) The value of equilibrium constant is changed in the presence of a catalyst in the reaction at equilibrium
- (4) Enzymes catalyse mainly bio-chemical reactions

Answer (3)

Sol. A catalyst decreases activation energies of both the forward and backward reaction by same amount, therefore, it speeds up both forward and backward reaction by same rate.

Equilibrium constant is therefore not affected by catalyst at a given temperature.

158. A gas is allowed to expand in a well insulated container against a constant external pressure of 2.5 atm from an initial volume of 2.50 L to a final volume of 4.50 L. The change in internal energy ΔU of the gas in joules will be

- (1) +505 J (2) 1136.25 J
 (3) -500 J (4) -505 J

Answer (4)

Sol. $\Delta U = q + w$

For adiabatic process, $q = 0$

$$\begin{aligned} \therefore \Delta U &= w \\ &= -P \cdot \Delta V \\ &= -2.5 \text{ atm} \times (4.5 - 2.5) \text{ L} \\ &= -2.5 \times 2 \text{ L-atm} \\ &= -5 \times 101.3 \text{ J} \\ &= -506.5 \text{ J} \\ &\approx -505 \text{ J} \end{aligned}$$

159. A 20 litre container at 400 K contains $\text{CO}_2(\text{g})$ at pressure 0.4 atm and an excess of SrO (neglect the volume of solid SrO). The volume of the container is now decreased by moving the movable piston fitted in the container. The maximum volume of the container, when pressure of CO_2 attains its maximum value, will be

(Given that : $\text{SrCO}_3(\text{s}) \rightleftharpoons \text{SrO}(\text{s}) + \text{CO}_2(\text{g})$.
 $K_p = 1.6 \text{ atm}$)

- (1) 2 litre (2) 5 litre
 (3) 10 litre (4) 4 litre

Answer (2)

Sol. Max. pressure of $\text{CO}_2 = \text{Pressure of } \text{CO}_2 \text{ at equilibrium}$

For reaction,

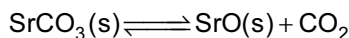

$K_p = P_{\text{CO}_2} = 1.6 \text{ atm} = \text{maximum pressure of } \text{CO}_2$

Volume of container at this stage,

$$V = \frac{nRT}{P} \quad \dots(i)$$

Since container is sealed and reaction was not earlier at equilibrium

$\therefore n = \text{constant}$

$$n = \frac{PV}{RT} = \frac{0.4 \times 20}{RT} \quad \dots(ii)$$

Put equation (ii) in equation (i)

$$V = \left[\frac{0.4 \times 20}{RT} \right] \frac{RT}{1.6} = 5 \text{ L}$$

160. Which of the following statements is not correct?

- (1) Denaturation makes the proteins more active
 (2) Insulin maintains sugar level in the blood of a human body
 (3) Ovalbumin is a simple food reserve in egg-white
 (4) Blood proteins thrombin and fibrinogen are involved in blood clotting

Answer (1)

Sol. Due to denaturation of proteins, globules unfold and helix get uncoiled and protein loses its biological activity.

161. Mechanism of a hypothetical reaction $\text{X}_2 + \text{Y}_2 \rightarrow 2\text{XY}$ is given below :

- (i) $\text{X}_2 \rightarrow \text{X} + \text{X}$ (fast)
 (ii) $\text{X} + \text{Y}_2 \rightleftharpoons \text{XY} + \text{Y}$ (slow)
 (iii) $\text{X} + \text{Y} \rightarrow \text{XY}$ (fast)

The overall order of the reaction will be

- (1) 1.5 (2) 1
 (3) 2 (4) 0

Answer (1)

Sol. The solution of this question is given by assuming step (i) to be reversible which is not given in question

Overall rate = Rate of slowest step (ii)

$$= k[\text{X}][\text{Y}_2] \quad \dots(1)$$

$k = \text{rate constant of step (ii)}$

Assuming step (i) to be reversible, its equilibrium constant,

$$k_{\text{eq}} = \frac{[\text{X}]^2}{[\text{X}_2]} \Rightarrow [\text{X}] = k_{\text{eq}}^{\frac{1}{2}} [\text{X}_2]^{\frac{1}{2}} \quad \dots(2)$$

Put (2) in (1)

$$\text{Rate} = k k_{\text{eq}}^{\frac{1}{2}} [\text{X}_2]^{\frac{1}{2}} [\text{Y}_2]$$

$$\text{Overall order} = \frac{1}{2} + 1 = \frac{3}{2}$$

162. In which pair of ions both the species contain S – S bond?

- (1) $S_4O_6^{2-}$, $S_2O_7^{2-}$ (2) $S_2O_7^{2-}$, $S_2O_3^{2-}$
 (3) $S_4O_6^{2-}$, $S_2O_3^{2-}$ (4) $S_2O_7^{2-}$, $S_2O_8^{2-}$

Answer (3)

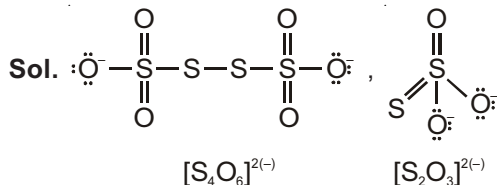

163. Which one of the following pairs of species have the same bond order?

- (1) N_2 , O_2^- (2) CO, NO
 (3) O_2 , NO^+ (4) CN^- , CO

Answer (4)

Sol. CN^- and CO have bond order 3 each.

164. Mixture of chloroxylenol and terpineol acts as

- (1) Antibiotic (2) Analgesic
 (3) Antiseptic (4) Antipyretic

Answer (3)

Sol. Mixture of chloroxylenol and terpineol acts as antiseptic.

165. It is because of inability of ns^2 electrons of the valence shell to participate in bonding that

- (1) Sn^{4+} is reducing while Pb^{4+} is oxidising
 (2) Sn^{2+} is reducing while Pb^{4+} is oxidising
 (3) Sn^{2+} is oxidising while Pb^{4+} is reducing
 (4) Sn^{2+} and Pb^{2+} are both oxidising and reducing

Answer (2)

Sol. Inability of ns^2 electrons of the valence shell to participate in bonding on moving down the group in heavier p-block elements is called **inert pair effect**

As a result, $Pb(II)$ is more stable than $Pb(IV)$

$Sn(IV)$ is more stable than $Sn(II)$

\therefore $Pb(IV)$ is easily reduced to $Pb(II)$

\therefore $Pb(IV)$ is oxidising agent

$Sn(II)$ is easily oxidised to $Sn(IV)$

\therefore $Sn(II)$ is reducing agent

166. For a given reaction, $\Delta H = 35.5 \text{ kJ mol}^{-1}$ and $\Delta S = 83.6 \text{ JK}^{-1} \text{ mol}^{-1}$. The reaction is spontaneous at : (Assume that ΔH and ΔS do not vary with temperature)

- (1) $T > 298 \text{ K}$ (2) $T < 425 \text{ K}$
 (3) $T > 425 \text{ K}$ (4) All temperatures

Answer (3)

Sol. $\therefore \Delta G = \Delta H - T\Delta S$

For a reaction to be spontaneous, $\Delta G = -ve$

i.e., $\Delta H < T\Delta S$

$$\therefore T > \frac{\Delta H}{\Delta S} = \frac{35.5 \times 10^3 \text{ J}}{83.6 \text{ JK}^{-1}}$$

i.e., $T > 425 \text{ K}$

167. If molality of the dilute solution is doubled, the value of molal depression constant (K_f) will be

- (1) Unchanged (2) Doubled
 (3) Halved (4) Tripled

Answer (1)

Sol. K_f (molal depression constant) is a characteristic of solvent and is independent of molality.

168. Which of the following is dependent on temperature?

- (1) Weight percentage (2) Molality
 (3) Molarity (4) Mole fraction

Answer (3)

Sol. Molarity includes volume of solution which can change with change in temperature.

169. Pick out the correct statement with respect $[Mn(CN)_6]^{3-}$

- (1) It is dsp^2 hybridised and square planar
 (2) It is sp^3d^2 hybridised and octahedral
 (3) It is sp^3d^2 hybridised and tetrahedral
 (4) It is d^2sp^3 hybridised and octahedral

Answer (4)

Sol. $[Mn(CN)_6]^{3-}$

$Mn(III) = [Ar]3d^4$

CN^- being strong field ligand forces pairing of electrons

This gives $t_{2g}^4 e_g^0$

∴ Mn(III) = [Ar]

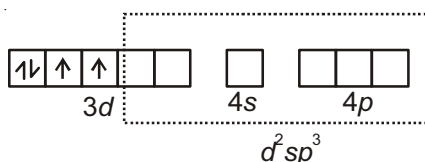

∴ Coordination number of Mn = 6

∴ Structure = octahedral

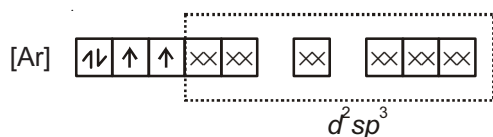

170. Which is the incorrect statement?

- (1) Frenkel defect is favoured in those ionic compounds in which sizes of cation and anions are almost equal
- (2) $\text{FeO}_{0.98}$ has non stoichiometric metal deficiency defect
- (3) Density decreases in case of crystals with Schottky's defect
- (4) $\text{NaCl}(\text{s})$ is insulator, silicon is semiconductor, silver is conductor, quartz is piezo electric crystal

Answer (1 & 2)*

Sol. Frenkel defect occurs in those ionic compounds in which size of cation and anion is largely different.

Non-stoichiometric ferrous oxide is $\text{Fe}_{0.93-0.96}\text{O}_{1.00}$ and it is due to metal deficiency defect.

171. HgCl_2 and I_2 both when dissolved in water containing I^- ions the pair of species formed is

- (1) $\text{Hg}_2\text{I}_2, \text{I}^-$
- (2) $\text{HgI}_2, \text{I}_3^-$
- (3) HgI_2, I^-
- (4) $\text{HgI}_4^{2-}, \text{I}_3^-$

Answer (4)

Sol. In a solution containing HgCl_2 , I_2 and I^- , both HgCl_2 and I_2 compete for I^- .

Since formation constant of $[\text{HgI}_4]^{2-}$ is 1.9×10^{30} which is very large as compared with I_3^- ($K_f = 700$)

∴ I^- will preferentially combine with HgCl_2 .

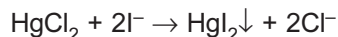

Red ppt

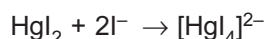

soluble

172. Extraction of gold and silver involves leaching with CN^- ion. Silver is later recovered by

- (1) Displacement with Zn
- (2) Liquefaction
- (3) Distillation
- (4) Zone refining

Answer (1)

Sol. Zn being more reactive than Ag and Au, displaces them.

From Native ore,

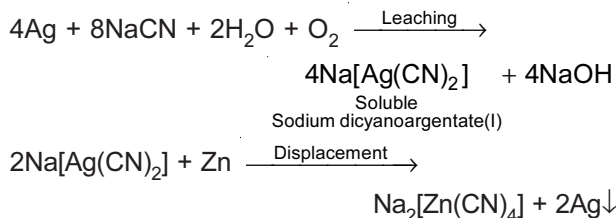

173. The correct order of the stoichiometries of AgCl formed when AgNO_3 in excess is treated with the complexes : $\text{CoCl}_3 \cdot 6\text{NH}_3$, $\text{CoCl}_3 \cdot 5\text{NH}_3$, $\text{CoCl}_3 \cdot 4\text{NH}_3$ respectively is

- (1) 2 AgCl , 3 AgCl , 1 AgCl
- (2) 1 AgCl , 3 AgCl , 2 AgCl
- (3) 3 AgCl , 1 AgCl , 2 AgCl
- (4) 3 AgCl , 2 AgCl , 1 AgCl

Answer (4)

Sol. Complexes are respectively $[\text{Co}(\text{NH}_3)_6]\text{Cl}_3$, $[\text{Co}(\text{NH}_3)_5\text{Cl}]\text{Cl}_2$ and $[\text{Co}(\text{NH}_3)_4\text{Cl}_2]\text{Cl}$

174. Identify A and predict the type of reaction

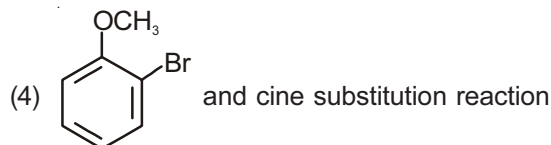
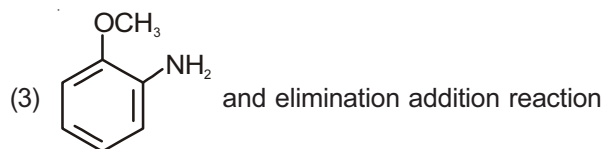
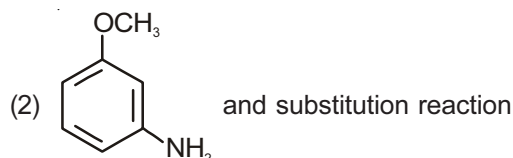
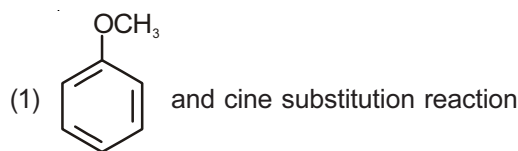
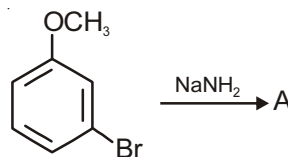

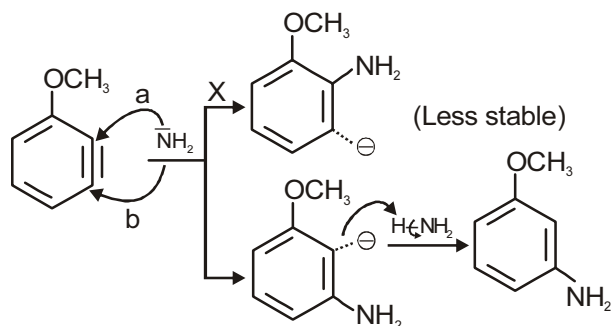
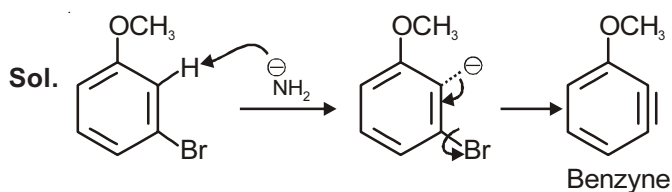
Answer (2)

More stable as $-ve$ charge is close to electron withdrawing group

\therefore Incoming nucleophile ends on same 'C' on which 'Br' (Leaving group) was present

\therefore **NOT** cine substitution.

175. An example of a sigma bonded organometallic compound is

- (1) Cobaltocene (2) Ruthenocene
(3) Grignard's reagent (4) Ferrocene

Answer (3)

Sol. Grignard's reagent *i.e.*, RMgX is σ -bonded organometallic compound.

176. The reason for greater range of oxidation states in actinoids is attributed to

- (1) $4f$ and $5d$ levels being close in energies
(2) The radioactive nature of actinoids
(3) Actinoid contraction
(4) $5f$, $6d$ and $7s$ levels having comparable energies

Answer (4)

Sol. It is a fact.

177. The element $Z = 114$ has been discovered recently. It will belong to which of the following family group and electronic configuration?

- (1) Nitrogen family, $[\text{Rn}] 5f^{14}6d^{10}7s^27p^6$
(2) Halogen family, $[\text{Rn}] 5f^{14}6d^{10}7s^27p^5$
(3) Carbon family, $[\text{Rn}] 5f^{14}6d^{10}7s^27p^2$
(4) Oxygen family, $[\text{Rn}] 5f^{14}6d^{10}7s^27p^4$

Answer (3)

Sol. $Z = 114$ belong to Group 14, carbon family
Electronic configuration = $[\text{Rn}]5f^{14}6d^{10}7s^27p^2$

178. A first order reaction has a specific reaction rate of 10^{-2} s^{-1} . How much time will it take for 20 g of the reactant to reduce to 5 g?

- (1) 693.0 second (2) 238.6 second
(3) 138.6 second (4) 346.5 second

Answer (3)

Sol. $t_{1/2} = \frac{0.693}{10^{-2}}$ second

For the reduction of 20 g of reactant to 5 g, two $t_{1/2}$ is required.

$$\therefore t = 2 \times \frac{0.693}{10^{-2}} \text{ second}$$

$$= 138.6 \text{ second}$$

179. Ionic mobility of which of the following alkali metal ions is lowest when aqueous solution of their salts are put under an electric field?

- (1) Li (2) Na
(3) K (4) Rb

Answer (1)

Sol. Li^+ being smallest, has maximum charge density

$\therefore \text{Li}^+$ is most heavily hydrated among all alkali metal ions. Effective size of Li^+ in aq solution is therefore, largest.

\therefore Moves slowest under electric field.

180. In the electrochemical cell

$\text{Zn}|\text{ZnSO}_4(0.01\text{M})||\text{CuSO}_4(1.0\text{M})|\text{Cu}$, the emf of this Daniel cell is E_1 . When the concentration of ZnSO_4 is changed to 1.0 M and that of CuSO_4 changed to 0.01 M, the emf changes to E_2 . From the following, which one is the relationship between E_1 and E_2 ?

(Given, $\frac{RT}{F} = 0.059$)

- (1) $E_2 = 0 \neq E_1$ (2) $E_1 = E_2$
(3) $E_1 < E_2$ (4) $E_1 > E_2$

Answer (4)

Sol. $\text{Zn}|\text{ZnSO}_4(0.01\text{M})||\text{CuSO}_4(1.0\text{M})|\text{Cu}$

$$\therefore E_1 = E_{\text{cell}}^{\circ} - \frac{2.303RT}{2 \times F} \times \log \frac{(0.01)}{1}$$

When concentrations are changed

$$\therefore E_2 = E_{\text{cell}}^{\circ} - \frac{2.303RT}{2F} \times \log \frac{1}{0.01}$$

i.e., $E_1 > E_2$