

CAT 2018 Slot 1

Verbal Ability

Instructions [1 - 5]

Read the following passage and answer the questions that follow:

Economists have spent most of the 20th century ignoring psychology, positive or otherwise. But today there is a great deal of emphasis on how happiness can shape global economies, or – on a smaller scale – successful business practice. This is driven, in part, by a trend in "measuring" positive emotions, mostly so they can be optimized. Neuroscientists, for example, claim to be able to locate specific emotions, such as happiness or disappointment, in particular areas of the brain. Wearable technologies, such as Spire, offer data-driven advice on how to reduce stress.

We are no longer just dealing with "happiness" in a philosophical or romantic sense – it has become something that can be monitored and measured, including by our behavior, use of social media and bodily indicators such as pulse rate and facial expressions.

There is nothing automatically sinister about this trend. But it is disquieting that the businesses and experts driving the quantification of happiness claim to have our best interests at heart, often concealing their own agendas in the process. In the workplace, happy workers are viewed as a "win-win." Work becomes more pleasant, and employees, more productive. But this is now being pursued through the use of performance-evaluating wearable technology, such as Humanyze or Virgin Pulse, both of which monitor physical signs of stress and activity toward the goal of increasing productivity.

Cities such as Dubai, which has pledged to become the "happiest city in the world," dream up ever-more elaborate and intrusive ways of collecting data on well-being – to the point where there is now talk of using CCTV cameras to monitor facial expressions in public spaces. New ways of detecting emotions are hitting the market all the time: One company, Beyond Verbal, aims to calculate moods conveyed in a phone conversation, potentially without the knowledge of at least one of the participants. And Facebook [has] demonstrated . . . that it could influence our emotions through tweaking our news feeds – opening the door to ever-more targeted manipulation in advertising and influence.

As the science grows more sophisticated and technologies become more intimate with our thoughts and bodies, a clear trend is emerging. Where happiness indicators were once used as a basis to reform society, challenging the obsession with money that G.D.P. measurement entrenches, they are increasingly used as a basis to transform or discipline individuals.

Happiness becomes a personal project, that each of us must now work on, like going to the gym. Since the 1970s, depression has come to be viewed as a cognitive or neurological defect in the individual, and never a consequence of circumstances. All of this simply escalates the sense of responsibility each of us feels for our own feelings, and with it, the sense of failure when things go badly. A society that deliberately removed certain sources of misery, such as precarious and exploitative employment, may well be a happier one. But we won't get there by making this single, often fleeting emotion, the over-arching goal.

1. From the passage we can infer that the author would like economists to:

- A work closely with neuroscientists to understand human behaviour.
- B incorporate psychological findings into their research cautiously.
- C correlate measurements of happiness with economic indicators.
- D measure the effectiveness of Facebook and social media advertising.

Answer: B

Explanation:

We can infer that the author adopts a cautionary tone in the passage. He warns that quantification of happiness might be useful in certain contexts but making measuring happiness the primary goal can lead to unwanted consequences. He warns that happiness will become a personal project if we take the metrics too seriously. Therefore, the author is likely to recommend economists to incorporate the research findings cautiously and hence, option B is the right answer.

2. According to the author, wearable technologies and social media are contributing most to:

- A making individuals aware of stress in their lives.
- B depression as a thing of the past.
- C disciplining individuals to be happy.
- D happiness as a “personal project”.

Answer: C

Explanation:

In the penultimate paragraph, the author mentions "Where happiness indicators were once used as a basis to reform society, challenging the obsession with money that G.D.P. measurement entrenches, they are increasingly used as a basis to transform or discipline individuals". He states that wearable technologies shift the onus on the person for his depression. In the last paragraph, the author mentions how these technologies are helping in disciplining individuals to be happy rather than addressing the cause of depression. Therefore, option C is the right answer.

3. In the author's opinion, the shift in thinking in the 1970s:

- A put people in touch with their own feelings rather than depending on psychologists.
- B was a welcome change from the earlier view that depression could be cured by changing circumstances.
- C introduced greater stress into people's lives as they were expected to be responsible for their own happiness.
- D reflected the emergence of neuroscience as the authority on human emotions.

Answer: C

Explanation:

In the last paragraph, the author mentions that since 1970s, depression is viewed as the defect of the individual rather than as the effect of his circumstances. He feels that this approach puts the person under pressure since being depressed is being viewed as the fault of the individual. The author does not view the shift in a positive light. Only option C captures the fact that the development was a detrimental step and hence, option C is the right answer.

4. The author's view would be undermined by which of the following research findings?

- A Stakeholders globally are moving away from collecting data on the well-being of individuals.
- B There is a definitive move towards the adoption of wearable technology that taps into emotions.
- C A proliferation of gyms that are collecting data on customer well-being.
- D Individuals worldwide are utilising technologies to monitor and increase their well-being.

Answer: A

Explanation:

The primary intention of the author is to warn about the trend of collecting data to monitor emotions and in turn promote happiness as an overarching goal. He says that such a practice will lead to adoption of intrusive methods and make happiness a personal project to be worked on. If it is proved that less data is being collected than earlier, it will weaken the very basis of the author's arguments.

Options B and C indicate a trend that the author is warning about. Therefore, we can eliminate these 2 options.

Option D states that individuals worldwide are using technologies to monitor their well-being. The author's argument is not that such

technologies should not be used. He just states that proliferation of such technologies, especially when used by external parties like nations and corporations, might put people under greater stress. Therefore, we can eliminate option D as well.

Option A states that stakeholders are moving away from collecting data. This statement goes against the warning issued by the author. Therefore, option A will undermine the author's arguments the most and hence, option A is the right answer.

5. According to the author, Dubai:

- A** collaborates with Facebook to selectively influence its inhabitants' moods.
- B** develops sophisticated technologies to monitor its inhabitants' states of mind.
- C** is on its way to becoming one of the world's happiest cities.
- D** incentivises companies that prioritise worker welfare.

Answer: B

Explanation:

The author does not consider happiness indicators to be the gold standard of happiness. Therefore, we cannot say that Dubai is on its way to becoming one of the happiest cities in the world just because it tries to discipline its citizens to be happy.

Nowhere has it been mentioned that Dubai collaborates with Facebook or incentivises companies that promote worker welfare.

'Cities such as Dubai, which has pledged to become the "happiest city in the world," dream up ever-more elaborate and intrusive ways of collecting data on well-being – to the point where there is now talk of using CCTV cameras to monitor facial expressions in public spaces'.

We can infer that Dubai comes up with new intrusive ways of collecting data on the well-being of its citizens. Therefore, option B is the right answer.

Instructions [6 - 10]

Read the passage carefully and answer the questions given

"Everybody pretty much agrees that the relationship between elephants and people has dramatically changed," says psychologist Gay Bradshaw, "Where for centuries humans and elephants lived in relatively peaceful coexistence, there is now hostility and violence. Now, I use the term 'violence' because of the intentionality associated with it, both in the aggression of humans and, at times, the recently observed behaviour of elephants."

Typically, elephant researchers have cited, as a cause of aggression, the high levels of testosterone in newly matured male elephants or the competition for land and resources between elephants and humans. But Bradshaw and several colleagues argue that today's elephant populations are suffering from a form of chronic stress, a kind of species-wide trauma. Decades of poaching and culling and habitat loss, they claim, have so disrupted the intricate web of familial and societal relations by which young elephants have traditionally been raised in the wild, and by which established elephant herds are governed, that what we are now witnessing is nothing less than a precipitous collapse of elephant culture.

Elephants, when left to their own devices, are profoundly social creatures. Young elephants are raised within an extended, multitiered network of doting female caregivers that includes the birth mother, grandmothers, aunts and friends. These relations are maintained over a life span as long as 70 years. Studies of established herds have shown that young elephants stay within 15 feet of their mothers for nearly all of their first eight years of life, after which young females are socialized into the matriarchal network, while young males go off for a time into an all-male social group before coming back into the fold as mature adults.

This fabric of elephant society, Bradshaw and her colleagues [demonstrate], ha[s] effectively been frayed by years of habitat loss and poaching, along with systematic culling by government agencies to control elephant numbers and translocations of herds to different habitats. . . . As a result of such social upheaval, calves are now being born to and raised by ever-younger and inexperienced mothers. Young orphaned elephants, meanwhile, that have witnessed the death of a parent at the hands of poachers are coming of age in the absence of the support system that defines traditional elephant life. "The loss of elephant elders," [says] Bradshaw, "and the traumatic experience of witnessing the massacres of their family, impairs normal brain and behaviour development in young elephants."

What Bradshaw and her colleagues describe would seem to be an extreme form of anthropocentric conjecture if the evidence that

they've compiled from various elephant researchers. . . weren't so compelling. The elephants of decimated herds, especially orphans who've watched the death of their parents and elders from poaching and culling, exhibit behaviour typically associated with post-traumatic stress disorder and other trauma-related disorders in humans: abnormal startle response, unpredictable asocial behaviour, inattentive mothering and hyper-aggression.

[According to Bradshaw], "Elephants are suffering and behaving in the same ways that we recognize in ourselves as a result of violence. Except perhaps for a few specific features, brain organization and early development of elephants and humans are extremely similar."

6. Which of the following statements best expresses the overall argument of this passage?

- A The brain organisation and early development of elephants and humans are extremely similar.
- B Recent elephant behaviour could be understood as a form of species-wide trauma related response.
- C The relationship between elephants and humans has changed from one of coexistence to one of hostility.
- D Elephants, like the humans they are in conflict with, are profoundly social creatures.

Answer: B

Explanation:

Through the passage, the author explains how the ways elephants behave is similar to the trauma related response evoked in individuals. He explains how the elephant society is affected by the human activity and the impact of the same on the brain development of young elephants.

The primary purpose of the passage is not to draw an analogy between elephants and humans in any way. Therefore, we can eliminate options A and D. Option C states that the relationship between elephants and humans has changed from one of coexistence to one of hostility. Though this point is true, it is not the central theme of the passage. The author places much emphasis on how the elephant behaviour can be explained as a species-wide trauma response and hence, option B is the right answer.

7. In paragraph 4, the phrase, "The fabric of elephant society . . . has[s] effectively been frayed by . . ." is:

- A an accurate description of the condition of elephant herds today.
- B a metaphor for the effect of human activity on elephant communities.
- C an exaggeration aimed at bolstering Bradshaw's claims.
- D an ode to the fragility of elephant society today.

Answer: B

Explanation:

The author uses strong comparison in the given line. The author has not mentioned that the elephant society, which is like a fabric, is frayed by human activities. He uses the term 'the fabric of elephant society' and this comparison is called a metaphor.

We can eliminate option A since it fails to capture the fact that a comparison has been used.

Option D states that the line is an ode to the fragility of elephant society today. Option D fails to capture the fact that human activities are wrecking the social structure of elephants.

Option C states that the line is an exaggeration to bolster Bradshaw's claims. The author is not exaggerating the facts to substantiate Bradshaw's claims. He tries to capture the effects of human activities on the elephant society metaphorically. Therefore, option B is the right answer.

8. The passage makes all of the following claims EXCEPT:

- A** elephants establish extended and enduring familial relationships as do humans.
- B** human actions such as poaching and culling have created stressful conditions for elephant communities.
- C** the elephant response to deeply disturbing experiences is similar to that of humans.
- D** elephant mothers are evolving newer ways of rearing their calves to adapt to emerging threats.

Answer: D

Explanation:

The author explains how elephants are profoundly social creatures like humans and how human activities are putting elephants under stress. Then, he explains how the recent elephant behaviour is similar to post traumatic stress syndrome observed in humans. Options A, B, and C can be inferred.

The author expresses apprehension that young calves are raised by inexperienced elephant mothers and this, in turn, affects the brain development of the calves. Nowhere has it been mentioned that elephant mothers are developing newer ways of rearing their calves. Therefore, option D is the right answer.

9. In the first paragraph, Bradshaw uses the term "violence" to describe the recent change in the human-elephant relationship because, according to her:

- A** both humans and elephants have killed members of each other's species.
- B** there is a purposefulness in human and elephant aggression towards each other.
- C** human-elephant interactions have changed their character over time.
- D** elephant herds and their habitat have been systematically destroyed by humans.

Answer: B

Explanation:

In the first paragraph of the passage, the author uses the line "Now, I use the term 'violence' because of the intentionality associated with it". Therefore, we can infer that the author specifically uses the term violence to emphasize that the actions of the elephants on humans are deliberate just like those of humans on elephants. Therefore, option B is the right answer.

10. Which of the following measures is Bradshaw most likely to support to address the problem of elephant aggression?

- A** The development of treatment programmes for elephants drawing on insights gained from treating post-traumatic stress disorder in humans.
- B** Increased funding for research into the similarity of humans and other animals drawing on insights gained from human-elephant similarities.
- C** Studying the impact of isolating elephant calves on their early brain development, behaviour and aggression.
- D** Funding of more studies to better understand the impact of testosterone on male elephant aggression.

Answer: A

Explanation:

The author tries to establish that the elephant behaviour is similar to stress related response induced in humans. From the tone of the passage, we can infer that the author is concerned about the elephants. He does not adopt a detached view point. The passage tries to evoke empathy from the audience and has not been written as a science research paper.

Options B, C, and D do not address the issue at hand. They are not steps towards addressing elephant aggression. Only option A proposes a method to treat the elephants and hence, option A is the right answer.

Instructions [11 - 15]

Read the following passage and answer the questions that follow:

The only thing worse than being lied to is not knowing you're being lied to. It's true that plastic pollution is a huge problem, of planetary proportions. And it's true we could all do more to reduce our plastic footprint. The lie is that blame for the plastic problem is wasteful consumers and that changing our individual habits will fix it.

Recycling plastic is to saving the Earth what hammering a nail is to halting a falling skyscraper. You struggle to find a place to do it and feel pleased when you succeed. But your effort is wholly inadequate and distracts from the real problem of why the building is collapsing in the first place. The real problem is that single-use plastic—the very idea of producing plastic items like grocery bags, which we use for an average of 12 minutes but can persist in the environment for half a millennium—is an incredibly reckless abuse of technology. Encouraging individuals to recycle more will never solve the problem of a massive production of single-use plastic that should have been avoided in the first place.

As an ecologist and evolutionary biologist, I have had a disturbing window into the accumulating literature on the hazards of plastic pollution. Scientists have long recognized that plastics biodegrade slowly, if at all, and pose multiple threats to wildlife through entanglement and consumption. More recent reports highlight dangers posed by absorption of toxic chemicals in the water and by plastic odors that mimic some species' natural food. Plastics also accumulate up the food chain, and studies now show that we are likely ingesting it ourselves in seafood. . . .

Beginning in the 1950s, big beverage companies like Coca-Cola and Anheuser-Busch, along with Phillip Morris and others, formed a non-profit called Keep America Beautiful. Its mission is/was to educate and encourage environmental stewardship in the public. . . . At face value, these efforts seem benevolent, but they obscure the real problem, which is the role that corporate polluters play in the plastic problem. This clever misdirection has led journalist and author Heather Rogers to describe Keep America Beautiful as the first corporate greenwashing front, as it has helped shift the public focus to consumer recycling behavior and actively thwarted legislation that would increase extended producer responsibility for waste management. . . . [T]he greatest success of Keep America Beautiful has been to shift the onus of environmental responsibility onto the public while simultaneously becoming a trusted name in the environmental movement. . . .

So what can we do to make responsible use of plastic a reality? First: reject the lie. Litterbugs are not responsible for the global ecological disaster of plastic. Humans can only function to the best of their abilities, given time, mental bandwidth and systemic constraints. Our huge problem with plastic is the result of a permissive legal framework that has allowed the uncontrolled rise of plastic pollution, despite clear evidence of the harm it causes to local communities and the world's oceans. Recycling is also too hard in most parts of the U.S. and lacks the proper incentives to make it work well.

11. It can be inferred that the author considers the Keep America Beautiful organisation:

- A an innovative example of a collaborative corporate social responsibility initiative.
- B a sham as it diverted attention away from the role of corporates in plastics pollution.
- C an important step in sensitising producers to the need to tackle plastics pollution.
- D a "greenwash" because it was a benevolent attempt to improve public recycling habits.

Answer: B

Explanation:

In the penultimate paragraph, the author uses the line "[T]he greatest success of Keep America Beautiful has been to shift the onus of environmental responsibility onto the public while simultaneously becoming a trusted name in the environmental movement". From the tone of the line, we can infer that the author believes that the sole purpose of 'Keep America Beautiful' was to shift the blame on the consumers. Therefore, option B is the right answer.

12. Which of the following interventions would the author most strongly support:

- A** having all consumers change their plastic consumption habits.
- B** recycling all plastic debris in the seabed.
- C** passing regulations targeted at producers that generate plastic products.
- D** completely banning all single-use plastic bags.

Answer: C

Explanation:

The author believes that the corporates are responsible for the plastic menace. He states that recycling the plastics or targeting the consumers are ineffective to tackle the problem.

' Encouraging individuals to recycle more will never solve the problem of a massive production of single-use plastic that should have been avoided in the first place'.

In the last paragraph, the author recommends responsible use of plastics. Therefore, he is unlikely to support a complete ban on single use plastics as well.

The author holds the corporates squarely responsible for the plastic menace. Therefore, the author is most likely to suggest passing regulations targeted at the producers rather than at the consumers. Therefore, option C is the right answer.

13. **The author lists all of the following as negative effects of the use of plastics EXCEPT the:**

- A** air pollution caused during the process of recycling plastics.
- B** poisonous chemicals released into the water and food we consume.
- C** adverse impacts on the digestive systems of animals exposed to plastic.
- D** slow pace of degradation or non-degradation of plastics in the environment.

Answer: A

Explanation:

In the third paragraph, the author mentions that plastics get absorbed in the water and some animals mistake plastic for their natural food and consume them. Therefore, we can infer options B and C. In the same paragraph, the author explains how plastics we use for a few minutes will stay on the planet for millions of years. Therefore, we can infer option D as well.

The author has not mentioned about air pollution caused while recycling the plastics anywhere in the passage. Therefore, option A is the right answer.

14. **In the second paragraph, the phrase “what hammering a nail is to halting a falling skyscraper” means:**

- A** focusing on single-use plastic bags to reduce the plastics footprint.
- B** encouraging the responsible production of plastics by firms.
- C** relying on emerging technologies to mitigate the ill-effects of plastic pollution.
- D** focusing on consumer behaviour to tackle the problem of plastics pollution.

Answer: D

Explanation:

The author believes that plastic production should be restricted. He finds asking consumers to stop using plastics or recycling plastics to be inadequate measures.

The author uses the analogy to drive home the point that focusing on consumer behaviour will be totally incommensurate to tackle plastic pollution. Therefore, option D is the right answer.

15. In the first paragraph, the author uses “lie” to refer to the:

- A understatement of the effects of recycling plastics.
- B understatement of the enormity of the plastics pollution problem.
- C blame assigned to consumers for indiscriminate use of plastics.
- D fact that people do not know they have been lied to.

Answer: C

Explanation:

The author uses the term 'lie' to emphasize that the fact that the consumers are made to believe that they are responsible for the plastic menace. Through out the passage, the author explains how the corporates tricked people into believing that the blame lies on them for using the plastics. Therefore, option C is the right answer.

Instructions [16 - 19]

Read the following passage and answer the questions that follow:

When researchers at Emory University in Atlanta trained mice to fear the smell of almonds (by pairing it with electric shocks), they found, to their consternation, that both the children and grandchildren of these mice were spontaneously afraid of the same smell. That is not supposed to happen. Generations of schoolchildren have been taught that the inheritance of acquired characteristics is impossible. A mouse should not be born with something its parents have learned during their lifetimes, any more than a mouse that loses its tail in an accident should give birth to tailless mice. . . .

Modern evolutionary biology dates back to a synthesis that emerged around the 1940s-60s, which married Charles Darwin’s mechanism of natural selection with Gregor Mendel’s discoveries of how genes are inherited. The traditional, and still dominant, view is that adaptations - from the human brain to the peacock’s tail - are fully and satisfactorily explained by natural selection (and subsequent inheritance). Yet [new evidence] from genomics, epigenetics and developmental biology [indicates] that evolution is more complex than we once assumed. . . .

In his book *On Human Nature* (1978), the evolutionary biologist Edward O Wilson claimed that human culture is held on a genetic leash. The metaphor [needs revision]. . . . Imagine a dog-walker (the genes) struggling to retain control of a brawny mastiff (human culture). The pair’s trajectory (the pathway of evolution) reflects the outcome of the struggle. Now imagine the same dog-walker struggling with multiple dogs, on leashes of varied lengths, with each dog tugging in different directions. All these tugs represent the influence of developmental factors, including epigenetics, antibodies and hormones passed on by parents, as well as the ecological legacies and culture they bequeath. . . .

The received wisdom is that parental experiences can’t affect the characters of their offspring. Except they do. The way that genes are expressed to produce an organism’s phenotype - the actual characteristics it ends up with - is affected by chemicals that attach to them. Everything from diet to air pollution to parental behaviour can influence the addition or removal of these chemical marks, which switches genes on or off. Usually these so-called ‘epigenetic’ attachments are removed during the production of sperm and eggs cells, but it turns out that some escape the resetting process and are passed on to the next generation, along with the genes. This is known as ‘epigenetic inheritance’, and more and more studies are confirming that it really happens. Let’s return to the almond-fearing mice. The inheritance of an epigenetic mark transmitted in the sperm is what led the mice’s offspring to acquire an inherited fear. . . .

Epigenetics is only part of the story. Through culture and society, [humans and other animals] inherit knowledge and skills acquired by [their] parents. . . . All this complexity . . . points to an evolutionary process in which genomes (over hundreds to thousands of generations), epigenetic modifications and inherited cultural factors (over several, perhaps tens or hundreds of generations), and parental effects (over single-generation timespans) collectively inform how organisms adapt. These extra-genetic kinds of inheritance give organisms the flexibility to make rapid adjustments to environmental challenges, dragging genetic change in their wake - much like a rowdy pack of dogs.

16. The passage uses the metaphor of a dog walker to argue that evolutionary adaptation is most comprehensively understood as being determined by:

- A ecological, hormonal, extra genetic and genetic legacies.
- B genetic, epigenetic, developmental factors, and ecological legacies.
- C extra genetic, genetic, epigenetic and genomic legacies.
- D socio-cultural, genetic, epigenetic, and genomic legacies.

Answer: B

Explanation:

The author mentions "All these tugs represent the influence of developmental factors, including epigenetics, antibodies and hormones passed on by parents, as well as the ecological legacies and culture they bequeath".

Option A misses 'developmental factors' and 'antibodies'.

Option C misses 'ecological legacies'.

Option D misses 'developmental factors'.

Option B is the most comprehensive one among the given options and hence, it is the right answer.

17. Which of the following options best describes the author's argument?

- A Wilson's theory of evolution is scientifically superior to either Darwin's or Mendel's.
- B Darwin's theory of natural selection cannot fully explain evolution.
- C Darwin's and Mendel's theories together best explain evolution.
- D Mendel's theory of inheritance is unfairly underestimated in explaining evolution.

Answer: B

Explanation:

The primary purpose of the passage is not to establish the scientific superiority of Wilson's theory over that of Darwin's and Mendel's theories. The author begins the passage with an example that the theory of natural selection fails to explain. Then, he explains about 'Epigenetic inheritance' and elaborates on how epigenetic inheritance explains the transmission of acquired characteristics. Therefore, the author's main argument is that Darwin's theory cannot fully explain evolution and hence, option B is the right answer.

18. Which of the following, if found to be true, would negate the main message of the passage?

- A A study affirming the sole influence of natural selection and inheritance on evolution.
- B A study highlighting the criticality of epigenetic inheritance to evolution.
- C A study indicating the primacy of ecological impact on human adaptation.
- D A study affirming the influence of socio-cultural markers on evolutionary processes.

Answer: A

Explanation:

The main message of the passage is that natural selection cannot fully explain evolution. Therefore, any argument that attacks this message is most likely to weaken the author's arguments. A study indicating the sole influence of natural selection and inheritance on evolution will question the legitimacy of the theory of 'epigenetic inheritance' and hence, option A is the right answer.

19. **The Emory University experiment with mice points to the inheritance of:**

- A** acquired parental fears
- B** acquired characteristics
- C** psychological markers
- D** personality traits

Answer: B

Explanation:

The author uses the Emory University experiment to show that acquired characteristics can be passed on from one generation to another. In the second paragraph, the author explains how the acquired characteristics (fear in this case) should not have been passed according to the theory of natural selection.

Option A is too narrow in scope. The author uses fear as an example of acquired characteristic. Therefore, option B is the right answer.

Instructions [20 - 24]

Read the following passage and answer the questions that follow:

[The] Indian government [has] announced an international competition to design a National War Memorial in New Delhi, to honour all of the Indian soldiers who served in the various wars and counterinsurgency campaigns from 1947 onwards. The terms of the competition also specified that the new structure would be built adjacent to the India Gate - a memorial to the Indian soldiers who died in the First World War. Between the old imperialist memorial and the proposed nationalist one, India's contribution to the Second World War is airbrushed out of existence.

The Indian government's conception of the war memorial was not merely absent-minded. Rather, it accurately reflected the fact that both academic history and popular memory have yet to come to terms with India's Second World War, which continues to be seen as little more than mood music in the drama of India's advance towards independence and partition in 1947. Further, the political trajectory of the postwar subcontinent has militated against popular remembrance of the war. With partition and the onset of the India-Pakistan rivalry, both of the new nations needed fresh stories for self-legitimation rather than focusing on shared wartime experiences.

The Indian army recruited, trained and deployed some 2.5 million men, almost 90,000 of which were killed and many more injured. Even at the time, it was recognised as the largest volunteer force in the war. . . . India's material and financial contribution to the war was equally significant. India emerged as a major military-industrial and logistical base for Allied operations in south-east Asia and the Middle East. This led the United States to take considerable interest in the country's future and ensured that this was no longer the preserve of the British government.

However, the Second World War played a crucial role in both the independence and partition of India and wartime developments pointed in the direction of India's independence. In a stunning reversal of its long-standing financial relationship with Britain, India finished the war as one of the largest creditors to the imperial power. Such extraordinary mobilization for war was achieved at a great human cost, with the Bengal famine the most extreme manifestation of widespread wartime deprivation. The costs on India's home front must be counted in millions of lives. Indians signed up to serve on the war and home fronts for a variety of reasons. . . . [M]any were convinced that their contribution would open the doors to India's freedom. . . . The political and social churn triggered by the war was evident in the massive waves of popular protest and unrest that washed over rural and urban India in the aftermath of the conflict. This turmoil was crucial in persuading the Attlee government to rid itself of the incubus of ruling India. . . .

Seventy years on, it is time that India engaged with the complex legacies of the Second World War. Bringing the war into the ambit of the new national memorial would be a fitting - if not overdue - recognition that this was India's War.

20. The author suggests that a major reason why India has not so far acknowledged its role in the Second World War is that it:

- A wants to forget the human and financial toll of the War on the country.
- B has been focused on building an independent, non-colonial political identity.
- C views the War as a predominantly Allied effort, with India playing only a supporting role.
- D blames the War for leading to the momentous partition of the country.

Answer: B

Explanation:

By the term "mood music", the author intends to convey that the war set the stage for the Independence and partition of the country. He does not mean that the war was an allied effort and India's contribution to the war was merely supportive.

The author mentions that the political trajectory in both the countries has been against the popular remembrance of war. He states that the countries were focused on building a non-colonial identity and the war narrative did not fit in well in the picture.

21. The phrase "mood music" is used in the second paragraph to indicate that the Second World War is viewed as:

- A setting the stage for the emergence of the India-Pakistan rivalry in the subcontinent.
- B a part of the narrative on the ill-effects of colonial rule on India.
- C a tragic period in terms of loss of lives and national wealth.
- D a backdrop to the subsequent independence and partition of the region.

Answer: D

Explanation:

The author uses the phrase "mood music" to indicate that (the contribution of Indians to) the Second World War is not given the importance it deserves. The author does not state that the war led to the rivalry. Though he mentions the ill-effects of the war on India, he does not refer to them when he uses the term "mood music". He feels that the war is largely seen as a warmer to the Independence and partition of the country. Therefore, option D is the right answer.

22. The author lists all of the following as outcomes of the Second World War EXCEPT:

- A US recognition of India's strategic location and role in the War.
- B the large financial debt India owed to Britain after the War.
- C large-scale deaths in Bengal as a result of deprivation and famine.
- D independence of the subcontinent and its partition into two countries.

Answer: B

Explanation:

In the fourth paragraph, the author states "This led the United States to take considerable interest in the country's future". We can infer that India's strategic location led to US's interests towards India and hence, we can eliminate option A.

In the first line of the second paragraph, the author mentions that the Second World War played a crucial role in the independence of India.

In the sixth paragraph, the author mentions that the war was achieved at great human cost. He states that the Bengal famine was the most extreme manifestation of the human costs of the war.

In the fifth paragraph, the author states "In a stunning reversal of its long-standing financial relationship with Britain, India finished the war as one of the largest creditors to the imperial power". From this line, we can infer that India lent its resources to Britain, not the other way around. Therefore, option B is an incorrect interpretation of the given sentence and hence, option B is the right answer.

23. **The author claims that omitting mention of Indians who served in the Second World War from the new National War Memorial is:**

- A** is something which can be rectified in future by constructing a separate memorial.
- B** a reflection of misplaced priorities of the post-independence Indian governments.
- C** appropriate as their names can always be included in the India Gate memorial.
- D** a reflection of the academic and popular view of India's role in the War.

Answer: D

Explanation:

In the second paragraph, the author mentions "Rather, it accurately reflected the fact that both academic history and popular memory have yet to come to terms with India's Second World War". The author states that the act was not merely absent-minded. Therefore, the author considers the omission to be reflective of India's academic and popular views and hence, option D is the right answer.

24. **In the first paragraph, the author laments the fact that:**

- A** the new war memorial will be built right next to India Gate.
- B** there is no recognition of the Indian soldiers who served in the Second World War.
- C** India lost thousands of human lives during the Second World War.
- D** funds will be wasted on another war memorial when we already have the India Gate memorial.

Answer: B

Explanation:

The author states that the new war memorial to commemorate various soldiers who lost their lives since independence will be built near India gate, a World War I memorial. The author regrets the fact that the contribution of Indian soldiers to World War II is being air brushed out of existence. The author laments the fact that the nation fails to recognize the sacrifice of the Indian soldiers who served in the World War II and hence, option B is the right answer.

25. **The passage given below is followed by four summaries. Choose the option that best captures the author's position.**

Production and legitimation of scientific knowledge can be approached from a number of perspectives. To study knowledge production from the sociology of professions perspective would mean a focus on the institutionalization of a body of knowledge. The professions-approach informed earlier research on managerial occupation, business schools and management knowledge. It however tends to reify institutional power structures in its understanding of the links between knowledge and authority. Knowledge production is restricted in the perspective to the selected members of the professional community, most notably to the university faculties and professional colleges. Power is understood as a negative mechanism, which prevents the non-professional actors from offering their ideas and information as legitimate knowledge.

- A** Professions-approach focuses on the creation of institutions of higher education and disciplines to promote knowledge production

- B** The study of knowledge production can be done through many perspectives.
- C** The professions-approach has been one of the most relied upon perspective in the study of management knowledge production.
- D** Professions-approach aims at the institutionalization of knowledge but restricts knowledge production as a function of a select few.

Answer: D

Explanation:

Let us note down the important points.

Professions-approach structures and institutionalizes knowledge but knowledge production is restricted to the select members of the community. It prevents the non-professional actors from offering their ideas.

Options A, B, and C do not capture the negative aspects of the professions-approach at all. They just focus on the advantages offered by the approach but the given paragraph places a huge emphasis on the limitations of the approach as well. Only option D captures both the advantage offered by the approach and its limitations. Therefore, option D is the right answer.

26. Five sentences related to a topic are given below. Four of them can be put together to form a meaningful and coherent short paragraph. Identify the ODD ONE out. Choose its number as your answer and key it in.

- 1) Translators are like bumblebees.
- 2) Though long since scientifically disproved, this factoid is still routinely trotted out.
- 3) Similar pronouncements about the impossibility of translation have dogged practitioners since Leonardo Bruni's *De interpretatione recta*, published in 1424.
- 4) Bees, unaware of these deliberations, have continued to flit from flower to flower, and translators continue to translate.
- 5) In 1934, the French entomologist August Magnan pronounced the flight of the bumblebee to be aerodynamically impossible.

Answer:2

Explanation:

On reading the sentences, we can infer that the author draws an analogy between translators and bumblebees in the paragraph.

1 should be the opening sentence since it introduces the fact that the paragraph is going to be about the similarities of translators and bumblebees. After sentence 1, the author should have explained how they are analogous.

5 states that the French entomologist August Magnan pronounced the flight of bumblebees to be aerodynamically impossible. Sentence 3 talks about similar statements made about translations. Sentence 4 should be the last sentence since it concludes by saying that both translators and bees have continued their work unaware of these deliberations. Sentences 1534 can be put together into a coherent paragraph.

Sentence 2 does not add any valuable information to the topic of discussion. The author does not use the fact that the factoid (impossibility of the flight of the bumblebee) has been disproved to support his argument. Sentence 2 should be the one out of context and hence, 2 is the correct answer.

27. Five sentences related to a topic are given below. Four of them can be put together to form a meaningful and coherent short paragraph. Identify the odd one out.

- 1) Displacement in Bengal is thus not very significant in view of its magnitude.
- 2) A factor of displacement in Bengal is the shifting course of the Ganges leading to erosion of river banks.
- 3) The nature of displacement in Bengal makes it an interesting case study.
- 4) Since displacement due to erosion is well spread over a long period of time, it remains invisible.
- 5) Rapid displacement would have helped sensitize the public to its human costs.

Answer:5

Explanation:

On reading the sentences, we can infer that the paragraph revolves around the displacement of people in Bengal due to erosion. 3 should be the opening sentence since it introduces the topic of discussion - displacement in Bengal. 3 should be followed by sentence 2 since it elaborates that the displacement is due to the shifting of the course of the Ganges and the erosion. We have to decide the pair between 5, 4, and 1.

Sentence 4 is definitely a part of the paragraph since it fits well with both the sentences. Also, it states an important detail - the displacement is spread out over a period of time and hence, remains invisible. Since the displacement is not rapid, its magnitude is not significant. Sentences 4 and 1 form a pair and hence, sentence 5 is the one out of context.

28. The passage given below is followed by four summaries. Choose the option that best captures the author's position.

The conceptualization of landscape as a geometric object first occurred in Europe and is historically related to the European conceptualization of the organism, particularly the human body, as a geometric object with parts having a rational, three-dimensional organization and integration. The European idea of landscape appeared before the science of landscape emerged, and it is no coincidence that Renaissance artists such as Leonardo da Vinci, who studied the structure of the human body, also facilitated an understanding of the structure of landscape. Landscape which had been a subordinate background to religious or historical narratives, became an independent genre or subject of art by the end of sixteenth century or the beginning of the seventeenth century.

- A The three-dimensional understanding of the organism in Europe led to a similar approach towards the understanding of landscape.
- B Landscape became a major subject of art at the turn of the sixteenth century.
- C The study of landscape as an independent genre was aided by the Renaissance artists.
- D The Renaissance artists were responsible for the study of landscape as a subject of art.

Answer: C

Explanation:

Let us note down the main points of the given paragraph:

The given paragraph describes how the study of landscape gained prominence and became an independent genre. Renaissance artists facilitated the development of the field as an independent genre.

Let us evaluate the options one by one.

Option A states that understanding of the organism in Europe led to a similar approach towards the understanding of landscape. Though this option is true, it fails to capture the fact that the field evolved as an independent genre with the help of Renaissance artists.

Option B states that Landscape became a major subject of art at the turn of the sixteenth century. Again, option B fails to capture the role played by the Renaissance artists.

Option D states that Renaissance artists were responsible for the study of landscape as a subject of art. The paragraph mentions that the artists facilitated in the transformation of the field into an independent genre. Option D establishes a strong relationship and holds Renaissance artists 'responsible' for the study of landscape 'as a subject of art'. The parts within the quotes disregard the fact that the artists just aided the process. They were not solely responsible for the development. Therefore, we can eliminate option D.

Only option C captures the fact that the renaissance artists 'aided' in the development of the study of landscape as an independent genre and hence, option C is the right answer.

29. **The four sentences (labelled 1,2,3,4) given in this question, when properly sequenced, form a coherent paragraph. Each sentence is labelled with a number. Decide on the proper sequence of order of the sentences and key in this sequence of four numbers as your answer.**

1. **Impartiality and objectivity are fiendishly difficult concepts that can cause all sorts of injustices even if transparently implemented.**
2. **It encourages us into bubbles of people we know and like, while blinding us to different perspectives, but the deeper problem of 'transparency' lies in the words "...and much more".**
3. **Twitter's website says that "tweets you are likely to care about most will show up first in your timeline...based on accounts you interact with most, tweets you engage with, and much more."**
4. **We are only told some of the basic principles, and we can't see the algorithm itself, making it hard for citizens to analyse the system sensibly or fairly or be convinced of its impartiality and objectivity.**

Answer:1324

Explanation:

On reading the sentences, we can infer that the paragraph is about the difficulty in implementing impartiality and objectivity.

Sentence 3 states that Twitter's website says that algorithm shows tweets that are likely to suit the taste of the user and much more. Sentence 2 continues sentence 3 by stating that the catch lies in the term 'much more'. Also, it criticizes how catering to the taste of the user forces him into a bubble. Sentence 2 should be followed by sentence 4 since it states the implications of the term 'much more' and how it makes believing in the impartiality and objectivity of twitter hard.

Sentences 324 form a group. The entire group has been provided as an illustration to explain how hard it is to implement impartiality and objectively. Therefore, sentence 1 should be the opening sentence.

Sentences 1324 form a coherent paragraph. Hence, 1324 is the correct answer.

30. **Five sentences related to a topic are given below. Four of them can be put together to form a meaningful and coherent short paragraph. Identify the odd one out.**

- 1) **In many cases time inconsistency is what prevents our going from intention to action.**
- 2) **For people to continuously postpone getting their children immunized, they would need to be constantly fooled by themselves.**
- 3) **In the specific case of immunization, however, it is hard to believe that time inconsistency by itself would be sufficient to make people permanently postpone the decision if they were fully cognizant of its benefits.**
- 4) **In most cases, even a small cost of immunization was large enough to discourage most people.**
- 5) **Not only do they have to think that they prefer to spend time going to the camp next month rather than today, they also have to believe that they will indeed go next month.**

Answer:4

Explanation:

All sentences except sentence 4 talk about how time inconsistency prevents people from immunizing their children. Sentence 4 states that the cost of immunization acts as a deterrent which is not in line with the other 4 sentences.

1 should be the opening sentence since it is a general statement introducing time inconsistency. Sentence 1 should be followed by sentence 3 since explains how time inconsistency, in itself, acts as a deterrent in the specific case of immunization. Sentences 2 and 5 form a pair. Sentence 2 states how people should be fooling themselves to postpone their child's immunization. Sentence 5 explains how they should be fooling themselves to not get their child immunized.

Sentences 1325 can be put together into a coherent paragraph. Therefore, 4 is the correct answer.

31. **The passage given below is followed by four summaries. Choose the option that best captures the author's position.**

Artificial embryo twinning is a relatively low-tech way to make clones. As the name suggests, this technique mimics the natural process that creates identical twins. In nature, twins form very early in development when the embryo splits in two. Twinning happens in the first days after egg and sperm join, while the embryo is made of just a small number of unspecialized cells. Each half of the embryo continues dividing on its own, ultimately developing into separate, complete individuals. Since they developed from the same fertilized egg, the resulting individuals are genetically identical.

- A** Artificial embryo twinning is low-tech and mimetic of the natural development of genetically identical twins from the embryo after fertilization.
- B** Artificial embryo twinning is low-tech and is close to the natural development of twins where the embryo splits into two identical twins.
- C** Artificial embryo twinning is low-tech unlike the natural development of identical twins from the embryo after fertilization.
- D** Artificial embryo twinning is just like the natural development of twins, where during fertilization twins are formed.

Answer: A

Explanation:

The author mentions that artificial embryo twinning is 'low tech' to introduce the topic. Then, he explains how the process is exactly similar to the process of development of twins. He states that the process mimics the natural development of twins. He has not highlighted any of the differences between the 2 processes.

Let us evaluate the options.

Option C states that artificial embryo twinning is 'low tech' unlike the natural development of twins. The author makes no such comparison in the paragraph and hence, option C can be eliminated.

Option D states that the twins are formed during fertilization but the paragraph mentions that the twins are formed after the process of fertilization (i.e, after the sperm and the egg join).

Option B fails to capture the fact that the twins are 'genetically' identical. Also, it states that the artificial twinning process is 'close to' the natural development of twins. Though this option is not incorrect, option A is worded in a better way. Option A states that the process is mimetic of the natural development of the twins (emphasizing that no difference has been highlighted), the twins are genetically identical and the process is similar to the process of development of twins after fertilization. Therefore, option A is the right answer.

32. The four sentences (labelled 1, 2, 3, and 4) given in this question, when properly sequenced, form a coherent paragraph. Decide on the proper order for the sentences and key in this sequence of four numbers as your answer.

1. The eventual diagnosis was skin cancer and after treatment all seemed well.
2. The viola player didn't know what it was; nor did her GP.
3. Then a routine scan showed it had come back and spread to her lungs.
4. It started with a lump on Cathy Perkins' index finger.

Answer:4213

Explanation:

Sentence 4 should be the opening sentence since it sets the scene and introduces the person suffering from cancer. Sentence 2 states that the viola player and her physician did not know what it was. 'It' refers to the lump on the finger. Sentence 1 should follow sentence 2 since it states what the eventual diagnosis was. The GP did not know what the lump was and later it was identified to be skin cancer. Sentence 1 states that all seemed well after the treatment, implying it was not. Sentence 3 should be the last sentence since it states that the cancer had spread to her lungs.

Sentences 4213 form a coherent paragraph and hence, 4213 is the right answer.

33. The four sentences (labelled 1,2,3,4) given in this question, when properly sequenced, form a coherent paragraph. Each sentence is labelled with a number. Decide on the proper sequence of order of the sentences and key in this sequence of four numbers as your Answer:

- 1) But now we have another group: the unwitting enablers.
- 2) Democracy and high levels of inequality of the kind that have come to characterize the United States are simply incompatible.
- 3) Believing these people are working for a better world, they are, actually, at most, chipping away at the margins, making slight course corrections, ensuring the system goes on as it is, uninterrupted.
- 4) Very rich people will always use money to maintain their political and economic power.

Answer:2413

Explanation:

2 should be the opening sentence since it sets the context for the discussion. It states that democracy and high levels of inequality are not compatible. Sentence 2 should be followed by sentence 4 since it states that very rich people will always try to buy power. The author is not surprised by this fact. Sentence 1 should follow sentence 4 since it states what the really unexpected thing is. The author states that we have a new group of people, 'the unwitting enablers'. Sentence 3 should follow sentence 4 since it elaborates on the nature of the unwitting enablers.

Sentences 2413 form a coherent paragraph and hence, 2413 is the right answer.

34. The four sentences (labelled 1, 2, 3, and 4) given in this question, when properly sequenced, form a coherent paragraph. Decide on the proper order for the sentences and key in this sequence of four numbers as your answer.

- 1) The woodland's canopy receives most of the sunlight that falls on the trees.
- 2) Swifts do not confine themselves to woodlands, but hunt wherever there are insects in the air.
- 3) With their streamlined bodies, swifts are agile flyers, ideally adapted to twisting and turning through the air as they chase flying insects - the creatures that form their staple diet.
- 4) Hundreds of thousands of insects fly in the sunshine up above the canopy, some falling prey to swifts and swallows

Answer:1432

Explanation:

1 should be the opening sentence since it sets the context. Sentence 1 states that the woodland's canopy receives most of the sunshine that falls on the trees. Sentence 4 continues sentence 1 by stating that thousands of insects fly above the canopy in the sunlight. The insects fall prey to the swifts and swallows.

We have to decide whether the order of the remaining 2 sentences is 32 or 23.

Sentence 3 states that swifts are agile flyers, adapted to chasing flying insects. Sentence 3 states that flying insects form the staple diet of the swifts. Sentence 2 states that swifts do not confine themselves to woodlands and hunt wherever they can find insects. Therefore, sentence 3 should precede sentence 2 (We cannot introduce that insects form the staple diet after stating that swifts hunt wherever they can find flying insects).

Sentences 1432 form a coherent paragraph.

Therefore, 1432 is the correct answer.

LRDI

Instructions [35 - 38]

Adriana, Bandita, Chitra, and Daisy are four female students, and Amit, Barun, Chetan, and Deb are four male students. Each of them studies in one of three institutes - X, Y, and Z. Each student majors in one subject among Marketing, Operations, and Finance, and minors in a different one among these three subjects. The following facts are known about the eight students:

1. Three students are from X, three are from Y, and the remaining two students, both female, are from Z.
2. Both the male students from Y minor in Finance, while the female student from Y majors in Operations.
3. Only one male student majors in Operations, while three female students minor in Marketing.
4. One female and two male students major in Finance.
5. Adriana and Deb are from the same institute. Daisy and Amit are from the same institute.
6. Barun is from Y and majors in Operations. Chetan is from X and majors in Finance.
7. Daisy minors in Operations.

35. **Who are the students from the institute Z?**

- A Chitra and Daisy
- B Adriana and Bandita
- C Bandita and Chitra
- D Adriana and Daisy

Answer: C

Explanation: Bandita and Chitra are from institute Z. Therefore, option C is the right answer.

36. **Which subject does Deb minor i**

- A Operations
- B Finance
- C Marketing
- D Cannot be determined uniquely from the given information

Answer: B

Explanation: Deb minors in Finance. Therefore, option B is the right answer.

37. Which subject does Amit major in?

- A Marketing
- B Operations
- C Cannot be determined uniquely from the given information
- D Finance

Answer: D

Explanation: Amit majors in finance. Therefore, option D is the right answer.

38. If Chitra majors in Finance, which subject does Bandita major in?

- A Finance
- B Cannot be determined uniquely from the given information
- C Operations
- D Marketing

Answer: C

Explanation: If Chitra majors in finance, Bandita cannot major in finance (only one female student majors in finance). She cannot major in marketing as well (since she has a minor degree in marketing). Therefore, Bandita should major in operations and hence, option C is the right answer.

Instructions [39 - 42]

An ATM dispenses exactly Rs. 5000 per withdrawal using 100, 200 and 500 rupee notes. The ATM requires every customer to give her preference for one of the three denominations of notes. It then dispenses notes such that the number of notes of the customer's preferred denomination exceeds the total number of notes of other denominations dispensed to her.

39. In how many different ways can the ATM serve a customer who gives 500 rupee notes as her preference?

Answer:7

Explanation:

It has been given that the customer gives 500 rupee notes as her preferred denomination. Therefore, the number of 500 rupee notes dispensed must be greater than the number of the notes of other denominations dispensed.

If Rs.3500 is dispensed as 500 rupee notes (7 notes), the remaining 1500 rupees should be dispensed using Rs.100 and Rs.200 notes. The minimum number of notes of other denomination required in this case will be 8 ($7*200 + 1*100$). Therefore, at least Rs.4000 should be dispensed as 500 rupee notes.

Case (1):

Rs.4000 is dispensed using 500 rupee notes, 8 five hundred rupee notes will be dispensed.

The remaining 1000 rupees cannot be fully dispensed as 100 rupee notes (since 10 notes will be required).

If 800 rupees is dispensed as 100 rupee notes, then 9 notes will be required to dispense 1000 rupees ($8*100+200$).

Therefore, we can eliminate these 2 cases.

If 600 rupees is dispensed using 100 rupee notes, then a minimum of 8 notes will be required to dispense 1000 rupees ($6*100 + 2*200$).

Therefore, we can eliminate this case as well.

If 400 rupees is dispensed using 100 rupee notes, then 7 notes will be required ($4*100+3*200$). This is a valid case.

If 200 rupees is dispensed using 100 rupee notes, then 6 notes will be required ($2*100+4*200$). This is a valid case.

1000 rupees can be dispensed using 5 notes of Rs.200.

Therefore, there are 3 valid cases.

Case (2):

Rs.4500 is dispensed using 500 rupee notes. 9 five hundred rupee notes will be dispensed in this case.

The remaining 500 rupees can be dispensed as 100 rupee notes (5 notes) or a combination of 100 rupee and 200 rupee notes.

$$200*a + 100*b = 500$$

'a' can take 0, 1, and 2.

Therefore, there are 3 valid cases.

Case (3):

5000 rupees is dispensed using 10 five hundred rupee notes.

There is only 1 valid case.

Total number of valid cases = $3+3+1 = 7$.

Therefore, 7 is the right answer.

40. If the ATM could serve only 10 customers with a stock of fifty 500 rupee notes and a sufficient number of notes of other denominations, what is the maximum number of customers among these 10 who could have given 500 rupee notes as their preferences?

Answer:6

Explanation:

If a customer gives 500 rupee notes as her preferred denomination, the number of 500 rupee notes dispensed must be greater than the number of the notes of other denominations dispensed.

If Rs.3500 is dispensed as 500 rupee notes (7 notes), the remaining 1500 rupees should be dispensed using Rs.100 and Rs.200 notes.

The minimum number of notes of other denomination required in this case will be 8 ($7*200 + 1*100$). Therefore, at least Rs.4000 should be dispensed as 500 rupee notes.

Case (1):

Rs.4000 is dispensed using 500 rupee notes, 8 five hundred rupee notes will be dispensed.

The remaining 1000 rupees cannot be fully dispensed as 100 rupee notes (since 10 notes will be required).

If 800 rupees is dispensed as 100 rupee notes, then 9 notes will be required to dispense 1000 rupees ($8*100+200$).

Therefore, we can eliminate these 2 cases.

If 600 rupees is dispensed using 100 rupee notes, then a minimum of 8 notes will be required to dispense 1000 rupees ($6*100 + 2*200$).

Therefore, we can eliminate this case as well.

If 400 rupees is dispensed using 100 rupee notes, then 7 notes will be required ($4*100+3*200$). This is a valid case.

If 200 rupees is dispensed using 100 rupee notes, then 6 notes will be required ($2*100+4*200$). This is a valid case.

1000 rupees can be dispensed using 5 notes of Rs.200.

Therefore, there are 3 valid cases.

Case (2):

Rs.4500 is dispensed using 500 rupee notes. 9 five hundred rupee notes will be dispensed in this case.

The remaining 500 rupees can be dispensed as 100 rupee notes (5 notes) or a combination of 100 rupee and 200 rupee notes.

$$200*a + 100*b = 500$$

'a' can take 0, 1, and 2.

Therefore, there are 3 valid cases.

Case (3):

5000 rupees is dispensed using 10 five hundred rupee notes.

There is only 1 valid case.

It has been given that the ATM could serve only 10 customers with a stock of fifty 500 rupee notes. We have to find the maximum number of customers who could have given Rs.500 as their preference.

The least number of 500 rupee notes required to serve a customer who has given Rs.500 as the preference is 8. Using 50 five hundred rupee notes, we can serve $\lfloor 500/8 \rfloor = 6$ customers. Therefore, 6 is the correct answer.

41. **What is the maximum number of customers that the ATM can serve with a stock of fifty 500 rupee notes and a sufficient number of notes of other denominations, if all the customers are to be served with at most 20 notes per withdrawal?**

A 12

B 10

C 13

D 16

Answer: A

Explanation:

It has been given that the customer has to receive 20 notes at the maximum. Also, we have restriction on the number of 500 rupee notes (fifty) but we do not have any restriction on the number of notes of other denominations. Therefore, in order to serve the maximum number of customers, we have to minimize the number of 500 rupee notes dispensed as much as possible.

If no 500 rupee note is dispensed, then a minimum of 25 notes will be required (25 200 rupee notes).

If one 500 rupee note is dispensed, then a minimum of one 100 rupee note and twenty two 200 rupee notes will be required. The total number of notes required = $1 + 1 + 22 = 24$. Therefore, we can eliminate this case.

If two 500 rupee notes are dispensed, then a minimum of 20 two hundred rupee notes will be required. We can eliminate this case as well since the number of notes required is greater than 20.

If three 500 rupee notes are dispensed, then a minimum of 1 hundred rupee note and 17 two hundred rupee notes will be required. The number of notes required in this case is $3+1+17 = 21$. Therefore, we can eliminate this case as well.

If four 500 rupee notes are dispensed, then a minimum of 15 two hundred rupee notes will be required. Total number of notes required in this case is $4+15 = 19 < 20$. Therefore, this is a valid case.

The least number of 500 rupee notes with which we can serve a customer such that the total number of notes dispensed does not exceed 20 is 4. Therefore, a maximum of $\lfloor 50/4 \rfloor = 12$ customers can be served with 50 five hundred rupee notes and hence, option A is the right answer.

42. **What is the number of 500 rupee notes required to serve 50 customers with 500 rupee notes as their preferences and another 50 customers with 100 rupee notes as their preferences, if the total number of notes to be dispensed is the smallest possible?**

A 900

B 800

C 750

D 1400

Answer: A

Explanation:

It has been given that the total number of notes dispensed is the smallest possible. Therefore, we have to minimize the number of notes dispensed in each of the 2 cases given.

The least number of notes required to serve a customer who has given 500 rupees as his preference is 10.

50 customers who have given 500 rupee notes as their preference have to be served. We will require $50 \times 10 = 500$ notes for this purpose.

Let us consider the case when a customer has given Rs.100 as his preference.

As we have seen, minimum number of notes will be required when we maximize the number of five hundred rupee notes as much as possible.

If Rs.4000 is dispensed using 500 rupee notes, the remaining 1000 rupees can be dispensed using ten 100 rupee notes. In this case, the number of 100 rupee notes (10) is greater than the number of 500 rupee notes (8). This is a valid case. We have to find if we can reduce the number of notes required any further.

We cannot increase the number of 500 rupee notes to 9 since only 5 hundred rupee notes can be dispensed, violating the condition that the customer has given 100 as his preferred denomination.

If we replace two 100 rupee notes with one 200 rupee note, then the number of 100 rupee notes will become 6. The number of 500 rupee notes (8) exceeds the number of 100 rupee note (6). Therefore, dispensing 4000 rupees using 500 rupee notes and the rest using 100 rupee notes represents the optimum condition.

The minimum number of notes required to serve 1 customer = 8 (five hundred notes) + 10 (hundred notes) = 18

Number of five hundred notes required to serve 50 customers = $8 \times 50 = 400$

Therefore, the total number of notes required = $400 + 500 = 900$.

Therefore, option A is the right answer.

Instructions [43 - 46]

You are given an $n \times n$ square matrix to be filled with numerals so that no two adjacent cells have the same numeral. Two cells are called adjacent if they touch each other horizontally, vertically or diagonally. So a cell in one of the four corners has three cells adjacent to it, and a cell in the first or last row or column which is not in the corner has five cells adjacent to it. Any other cell has eight cells adjacent to it.

43. What is the minimum number of different numerals needed to fill a 3×3 square matrix?

Answer:4

Explanation:

Let us use 1 to denote the first number that we fill. We have to fill as many squares with 1 as possible. If we start with the top-left square, we can fill 4 squares with the number 1.

1		1
1		1

Now, we can fill number 2 only in 2 of the 5 squares available.

1	2	1
1	2	1

The 3 squares available now are adjacent to each other. Therefore, we will require at least 2 numbers to fill these squares.

1	2	1
3	4	3
1	2	1

We need a minimum of 4 numbers to fill a 3x3 square matrix such that no 2 adjacent cells contain the same number. Therefore, 4 is the correct answer.

44. What is the minimum number of different numerals needed to fill a 5x5 square matrix?

Answer:4

Explanation:

Let us consider a 5x5 matrix. Let us start with the top left square and fill number 1 in as many squares as possible.

1		1		1
1		1		1
1		1		1

We have to use a second number, 2 to fill the gap between two 1s.

1	2	1	2	1
1	2	1	2	1
1	2	1	2	1

All the cells in row 2 and row 4 are adjacent to the cells containing numbers 1 and 2. Therefore, rows 2 and 4 should be filled with a new

set of numbers. We need at least 2 numbers to fill a row such that the adjacent cells do not contain the same number (by alternating the numbers in the consecutive cells). Rows 2 and 4 are completely isolated from each other and hence, the same set of numbers can be used to fill both the rows.

1	2	1	2	1
3	4	3	4	3
1	2	1	2	1
3	4	3	4	3
1	2	1	2	1

As we can see, a minimum of 4 numbers are required to fill a 5x5 matrix. Therefore, 4 is the correct answer.

45. Suppose you are allowed to make one mistake, that is, one pair of adjacent cells can have the same numeral. What is the minimum number of different numerals required to fill a 5x5 matrix?

- A 4
- B 16
- C 9
- D 25

Answer: A

Explanation:

Let us consider a 5x5 matrix. Let us start with the top left square and fill number 1 in as many squares as possible.

1		1		1
1		1		1
1		1		1

We have to use a second number, 2 to fill the gap between two 1s.

1	2	1	2	1
1	2	1	2	1
1	2	1	2	1

All the cells in row 2 and row 4 are adjacent to the cells containing numbers 1 and 2. Therefore, rows 2 and 4 should be filled with a new set of numbers. We need at least 2 numbers to fill a row such that the adjacent cells do not contain the same number (by alternating the numbers in the consecutive cells). Rows 2 and 4 are completely isolated from each other and hence, the same set of numbers can be used to fill both the rows.

1	2	1	2	1
3	4	3	4	3
1	2	1	2	1
3	4	3	4	3
1	2	1	2	1

4 numbers are required to fill a 5x5 matrix.

It has been given that we are allowed to make 1 mistake - One pair of adjacent cells can contain the same number. In the arrangement given above, we can alter any value along the edge to satisfy this condition. For example, the 2 in the bottom-most row can be changed to 4. Still, the number of numbers required to fill the matrix will be 4.

Another way to approach this problem is as follows:

We know that a minimum of 4 numbers are required to fill a 5x5 matrix. If we are allowed to make a mistake, then the number of numbers required should either remain the same or go down. 4 is the smallest value among the given options. Therefore, we can be sure that even if we are allowed to make a mistake, 4 numbers will be required to fill the matrix and hence, option A is the right answer.

46. **Suppose that all the cells adjacent to any particular cell must have different numerals. What is the minimum number of different numerals needed to fill a 5×5 square matrix?**

- A 25
- B 4
- C 16
- D 9

Answer: D

Explanation:

It has been given that all the cells adjacent to a cell must have different numerals. Let us start filling the matrix from the central square since the central square has the maximum number of squares adjacent to it (8) and it will be easier to work around the central 9 squares. A minimum of 9 numbers will be required to fill the central 9 squares.

	2	3	4	
	9	1	5	
	8	7	6	

Now we have to fill the remaining squares. Let us start with the top left square. We have to check whether the 9 numbers will be sufficient to fill all the squares such that no 2 squares adjacent to a square have the same number. We can use any of the 3 numbers 4, 5, and 6 to fill the top left square since none of the numbers in the second column are adjacent to these numbers.

Let us assume that we use 4 to fill the top left square. Now, one of the cells with the number 4 has become adjacent to the cell with number 2 and no other cell adjacent to cell with number 2 (in the second row and second column) can have 4 as its neighbour. Similarly, we can fill the first row with numbers 8 and 7.

4	7	8		
5	2	3	4	
6	9	1	5	
	8	7	6	

In essence, we are trying to create a grid around each of the numbers in the corners of the inner 3x3 matrix such that no 2 cells adjacent to a cell have the same number. Filling the other cells similarly, we get the following matrix as one of the possible cases.

4	7	8	6	7
5	2	3	4	9
6	9	1	5	2
3	8	7	6	8
2	5	4	3	9

We need a minimum of 9 numbers to fill a 5x5 matrix such that for any cell, no 2 cells adjacent to it contain the same value. Therefore, option D is the right answer.

Instructions [47 - 50]

Fuel contamination levels at each of 20 petrol pumps P1, P2, ..., P20 were recorded as either high, medium, or low.

1. Contamination levels at three pumps among P1 - P5 were recorded as high.
2. P6 was the only pump among P1 - P10 where the contamination level was recorded as low.
3. P7 and P8 were the only two consecutively numbered pumps where the same levels of contamination were recorded.
4. High contamination levels were not recorded at any of the pumps P16 - P20.

5. The number of pumps where high contamination levels were recorded was twice the number of pumps where low contamination levels were recorded.

47. Which of the following **MUST** be true?

- A The contamination level at P20 was recorded as medium.
- B The contamination level at P13 was recorded as low.
- C The contamination level at P12 was recorded as high.
- D The contamination level at P10 was recorded as high.

Answer: D

Explanation:

Let us draw the table and fill all absolute information present.

Pumps	Contamination level
P1	
P2	
P3	
P4	
P5	
P6	Low
P7	
P8	
P9	
P10	
P11	
P12	
P13	
P14	
P15	
P16	
P17	
P18	
P19	
P20	

In statement 3, it is given that P7 and P8 were the only two consecutively numbered pumps where the same levels of contamination were recorded.

In statement 1, it is given that contamination levels at three pumps among P1 - P5 were recorded as high. This is only possible when pumps 1, 3 and 5 have high level of contamination. Also, P6 was the only pump among P1 - P10 where the contamination level was recorded as low. Therefore, we can say that pumps 2 and 4 have medium level of contamination.

Pumps	Contamination level
P1	High
P2	Medium
P3	High
P4	Medium
P5	High
P6	Low
P7	
P8	
P9	
P10	
P11	
P12	
P13	
P14	
P15	
P16	
P17	
P18	
P19	
P20	

It is given that High contamination levels were not recorded at any of the pumps P16 - P20. Therefore, we can say that High contamination was recorded in only first 15 pumps. Therefore, we can say that the maximum number of pumps that can have high contamination level is '8'. (Consecutive pumps don't have same contamination level except one case)

Also, it is given that the number of pumps where high contamination levels were recorded was twice the number of pumps where low contamination levels were recorded. Hence, we can say that the number of pumps that have high contamination level is an even number less than or equal to '8'.

If the number of high contamination level pumps is '6', then there will be only '3' pumps with low contamination level. Consequently, we will need 11 (20 - 6 - 3) pumps with medium contamination level which is not possible since the number of pumps of a single type can't exceed 10. (Consecutive pumps don't have same contamination level except one case)

Therefore, we can say that the number of pumps that have high contamination level = 8

The number of pumps that have low contamination level = $8/2 = 4$

Also, the number of pumps that have medium contamination level = $20 - 8 - 4 = 12$

It is given that P7 and P8 were the only two consecutively numbered pumps where the same levels of contamination were recorded. If P7 and P8 recorded medium contamination level then there can be at max 7 pumps (P1, P3, P5, P9, P11, P13, P15) with high contamination level. Hence, we can say that pumps P7 and P8 recorded High contamination level. Therefore, we can uniquely determine the contamination level till P10.

Pumps	Contamination level
P1	High
P2	Medium
P3	High
P4	Medium
P5	High
P6	Low
P7	High
P8	High
P9	Medium
P10	High
P11	
P12	
P13	
P14	
P15	
P16	
P17	
P18	
P19	
P20	

It is given that High contamination levels were not recorded at any of the pumps P16 - P20. Therefore, we can say that these 5 pumps recorded low and medium contamination level. There are two cases possible.

Case 1: When there were 3 Low and 2 Medium contaminated level recorded in pumps P16 - P20.

3 Low contamination level must have recorded in P16, P18 and P20. We can fill the table as follows.

Pumps	Contamination level
P1	High
P2	Medium
P3	High
P4	Medium
P5	High
P6	Low
P7	High
P8	High
P9	Medium
P10	High
P11	Medium
P12	High
P13	Medium
P14	High
P15	Medium
P16	Low
P17	Medium
P18	Low
P19	Medium
P20	Low

Case 2: When there were 2 Low and 3 Medium contaminated level recorded in pumps P16 - P20.

3 Medium contamination level must have recorded in P16, P18 and P20. We can fill the table as follows.

Pumps	Contamination level
P1	High
P2	Medium
P3	High
P4	Medium
P5	High
P6	Low
P7	High
P8	High
P9	Medium
P10	High
P11	Low
P12	Medium
P13	High
P14	Medium
P15	High
P16	Medium
P17	Low
P18	Medium
P19	Low
P20	Medium

Pumps	Contamination level
P1	High
P2	Medium
P3	High
P4	Medium
P5	High
P6	Low
P7	High
P8	High
P9	Medium
P10	High
P11	Medium
P12	Low
P13	High
P14	Medium
P15	High
P16	Medium
P17	Low
P18	Medium
P19	Low
P20	Medium

Pumps	Contamination level
P1	High
P2	Medium
P3	High
P4	Medium
P5	High
P6	Low
P7	High
P8	High
P9	Medium
P10	High
P11	Medium
P12	High
P13	Low
P14	Medium
P15	High
P16	Medium
P17	Low
P18	Medium
P19	Low
P20	Medium

Pumps	Contamination level
P1	High
P2	Medium
P3	High
P4	Medium
P5	High
P6	Low
P7	High
P8	High
P9	Medium
P10	High
P11	Medium
P12	High
P13	Medium
P14	Low
P15	High
P16	Medium
P17	Low
P18	Medium
P19	Low
P20	Medium

Pumps	Contamination level
P1	High
P2	Medium
P3	High
P4	Medium
P5	High
P6	Low
P7	High
P8	High
P9	Medium
P10	High
P11	Medium
P12	High
P13	Medium
P14	High
P15	Low
P16	Medium
P17	Low
P18	Medium
P19	Low
P20	Medium

Let us check the options one by one.

(Option:A) The contamination level at P20 was recorded as medium. This need not be true as we can see that in Case 1 at P20 low contamination level is recorded.

(Option:B) The contamination level at P13 was recorded as low. This need not be true as we can see that in Case 2(a), at P13 high contamination level is recorded.

(Option:C) The contamination level at P12 was recorded as high. This need not be true as we can see that in Case 2(a), at P12 medium contamination level is recorded.

(Option:D) The contamination level at P10 was recorded as high.. This is true for all cases. Hence, we can say that option D is the correct answer.

48. What best can be said about the number of pumps at which the contamination levels were recorded as medium?

- A At least 8
- B More than 4
- C Exactly 8
- D At most 9

Answer: C

Explanation:

Let us draw the table and fill all absolute information present.

Pumps	Contamination level
P1	
P2	
P3	
P4	
P5	
P6	Low
P7	
P8	
P9	
P10	
P11	
P12	
P13	
P14	
P15	
P16	
P17	
P18	
P19	
P20	

In statement 3, it is given that P7 and P8 were the only two consecutively numbered pumps where the same levels of contamination were recorded.

In statement 1, it is given that contamination levels at three pumps among P1 - P5 were recorded as high. This is only possible when pumps 1, 3 and 5 have high level of contamination. Also, P6 was the only pump among P1 - P10 where the contamination level was recorded as low. Therefore, we can say that pumps 2 and 4 have medium level of contamination.

Pumps	Contamination level
P1	High
P2	Medium
P3	High
P4	Medium
P5	High
P6	Low
P7	
P8	
P9	
P10	
P11	
P12	
P13	
P14	
P15	
P16	
P17	
P18	
P19	
P20	

It is given that High contamination levels were not recorded at any of the pumps P16 - P20. Therefore, we can say that High contamination was recorded in only first 15 pumps. Therefore, we can say that the maximum number of pumps that can have high contamination level is '8'. (Consecutive pumps don't have same contamination level except one case)

Also, it is given that the number of pumps where high contamination levels were recorded was twice the number of pumps where low contamination levels were recorded. Hence, we can say that the number of pumps that have high contamination level is an even number less than or equal to '8'.

If the number of high contamination level pumps is '6', then there will be only '3' pumps with low contamination level. Consequently, we will need 11 (20 - 6 - 3) pumps with medium contamination level which is not possible since the number of pumps of a single type can't exceed 10. (Consecutive pumps don't have same contamination level except one case)

Therefore, we can say that the number of pumps that have high contamination level = 8

The number of pumps that have low contamination level = $8/2 = 4$

Also, the number of pumps that have medium contamination level = $20 - 8 - 4 = 12$

It is given that P7 and P8 were the only two consecutively numbered pumps where the same levels of contamination were recorded. If P7 and P8 recorded medium contamination level then there can be at max 7 pumps (P1, P3, P5, P9, P11, P13, P15) with high contamination level. Hence, we can say that pumps P7 and P8 recorded High contamination level. Therefore, we can uniquely determine the contamination level till P10.

Pumps	Contamination level
P1	High
P2	Medium
P3	High
P4	Medium
P5	High
P6	Low
P7	High
P8	High
P9	Medium
P10	High
P11	
P12	
P13	
P14	
P15	
P16	
P17	
P18	
P19	
P20	

It is given that High contamination levels were not recorded at any of the pumps P16 - P20. Therefore, we can say that these 5 pumps recorded low and medium contamination level. There are two cases possible.

Case 1: When there were 3 Low and 2 Medium contaminated level recorded in pumps P16 - P20.

3 Low contamination level must have recorded in P16, P18 and P20. We can fill the table as follows.

Pumps	Contamination level
P1	High
P2	Medium
P3	High
P4	Medium
P5	High
P6	Low
P7	High
P8	High
P9	Medium
P10	High
P11	Medium
P12	High
P13	Medium
P14	High
P15	Medium
P16	Low
P17	Medium
P18	Low
P19	Medium
P20	Low

Case 2: When there were 2 Low and 3 Medium contaminated level recorded in pumps P16 - P20.

3 Medium contamination level must have recorded in P16, P18 and P20. We can fill the table as follows.

Pumps	Contamination level
P1	High
P2	Medium
P3	High
P4	Medium
P5	High
P6	Low
P7	High
P8	High
P9	Medium
P10	High
P11	Low
P12	Medium
P13	High
P14	Medium
P15	High
P16	Medium
P17	Low
P18	Medium
P19	Low
P20	Medium

Pumps	Contamination level
P1	High
P2	Medium
P3	High
P4	Medium
P5	High
P6	Low
P7	High
P8	High
P9	Medium
P10	High
P11	Medium
P12	Low
P13	High
P14	Medium
P15	High
P16	Medium
P17	Low
P18	Medium
P19	Low
P20	Medium

Pumps	Contamination level
P1	High
P2	Medium
P3	High
P4	Medium
P5	High
P6	Low
P7	High
P8	High
P9	Medium
P10	High
P11	Medium
P12	High
P13	Low
P14	Medium
P15	High
P16	Medium
P17	Low
P18	Medium
P19	Low
P20	Medium

Pumps	Contamination level
P1	High
P2	Medium
P3	High
P4	Medium
P5	High
P6	Low
P7	High
P8	High
P9	Medium
P10	High
P11	Medium
P12	High
P13	Medium
P14	Low
P15	High
P16	Medium
P17	Low
P18	Medium
P19	Low
P20	Medium

Pumps	Contamination level
P1	High
P2	Medium
P3	High
P4	Medium
P5	High
P6	Low
P7	High
P8	High
P9	Medium
P10	High
P11	Medium
P12	High
P13	Medium
P14	High
P15	Low
P16	Medium
P17	Low
P18	Medium
P19	Low
P20	Medium

We know that medium contamination level was recorded at exactly 8 pumps. Hence, option C is the correct answer.

49. If the contamination level at P11 was recorded as low, then which of the following **MUST** be true?

- A The contamination level at P12 was recorded as high.
- B The contamination level at P15 was recorded as medium.
- C The contamination level at P18 was recorded as low.
- D The contamination level at P14 was recorded as medium.

Answer: D

Explanation:

Let us draw the table and fill all absolute information present.

Pumps	Contamination level
P1	
P2	
P3	
P4	
P5	
P6	Low
P7	
P8	
P9	
P10	
P11	
P12	
P13	
P14	
P15	
P16	
P17	
P18	
P19	
P20	

In statement 3, it is given that P7 and P8 were the only two consecutively numbered pumps where the same levels of contamination were recorded.

In statement 1, it is given that contamination levels at three pumps among P1 - P5 were recorded as high. This is only possible when

pumps 1, 3 and 5 have high level of contamination. Also, P6 was the only pump among P1 - P10 where the contamination level was recorded as low. Therefore, we can say that pumps 2 and 4 have medium level of contamination.

Pumps	Contamination level
P1	High
P2	Medium
P3	High
P4	Medium
P5	High
P6	Low
P7	
P8	
P9	
P10	
P11	
P12	
P13	
P14	
P15	
P16	
P17	
P18	
P19	
P20	

It is given that High contamination levels were not recorded at any of the pumps P16 - P20. Therefore, we can say that High contamination was recorded in only first 15 pumps. Therefore, we can say that the maximum number of pumps that can have high contamination level is '8'. (Consecutive pumps don't have same contamination level except one case)

Also, it is given that the number of pumps where high contamination levels were recorded was twice the number of pumps where low contamination levels were recorded. Hence, we can say that the number of pumps that have high contamination level is an even number less than or equal to '8'.

If the number of high contamination level pumps is '6', then there will be only '3' pumps with low contamination level. Consequently, we will need 11 (20 - 6 - 3) pumps with medium contamination level which is not possible since the number of pumps of a single type can't exceed 10. (Consecutive pumps don't have same contamination level except one case)

Therefore, we can say that the number of pumps that have high contamination level = 8

The number of pumps that have low contamination level = $8/2 = 4$

Also, the number of pumps that have medium contamination level = $20 - 8 - 4 = 12$

It is given that P7 and P8 were the only two consecutively numbered pumps where the same levels of contamination were recorded. If P7 and P8 recorded medium contamination level then there can be at max 7 pumps (P1, P3, P5, P9, P11, P13, P15) with high contamination level. Hence, we can say that pumps P7 and P8 recorded High contamination level. Therefore, we can uniquely determine the contamination level till P10.

Pumps	Contamination level
P1	High
P2	Medium
P3	High
P4	Medium
P5	High
P6	Low
P7	High
P8	High
P9	Medium
P10	High
P11	
P12	
P13	
P14	
P15	
P16	
P17	
P18	
P19	
P20	

It is given that High contamination levels were not recorded at any of the pumps P16 - P20. Therefore, we can say that these 5 pumps recorded low and medium contamination level. There are two cases possible.

Case 1: When there were 3 Low and 2 Medium contaminated level recorded in pumps P16 - P20.

3 Low contamination level must have recorded in P16, P18 and P20. We can fill the table as follows.

Pumps	Contamination level
P1	High
P2	Medium
P3	High
P4	Medium
P5	High
P6	Low
P7	High
P8	High
P9	Medium
P10	High
P11	Medium
P12	High
P13	Medium
P14	High
P15	Medium
P16	Low
P17	Medium
P18	Low
P19	Medium
P20	Low

Case 2: When there were 2 Low and 3 Medium contaminated level recorded in pumps P16 - P20.

3 Medium contamination level must have recorded in P16, P18 and P20. We can fill the table as follows.

Pumps	Contamination level
P1	High
P2	Medium
P3	High
P4	Medium
P5	High
P6	Low
P7	High
P8	High
P9	Medium
P10	High
P11	Low
P12	Medium
P13	High
P14	Medium
P15	High
P16	Medium
P17	Low
P18	Medium
P19	Low
P20	Medium

Pumps	Contamination level
P1	High
P2	Medium
P3	High
P4	Medium
P5	High
P6	Low
P7	High
P8	High
P9	Medium
P10	High
P11	Medium
P12	Low
P13	High
P14	Medium
P15	High
P16	Medium
P17	Low
P18	Medium
P19	Low
P20	Medium

Pumps	Contamination level
P1	High
P2	Medium
P3	High
P4	Medium
P5	High
P6	Low
P7	High
P8	High
P9	Medium
P10	High
P11	Medium
P12	High
P13	Low
P14	Medium
P15	High
P16	Medium
P17	Low
P18	Medium
P19	Low
P20	Medium

Pumps	Contamination level
P1	High
P2	Medium
P3	High
P4	Medium
P5	High
P6	Low
P7	High
P8	High
P9	Medium
P10	High
P11	Medium
P12	High
P13	Medium
P14	Low
P15	High
P16	Medium
P17	Low
P18	Medium
P19	Low
P20	Medium

Pumps	Contamination level
P1	High
P2	Medium
P3	High
P4	Medium
P5	High
P6	Low
P7	High
P8	High
P9	Medium
P10	High
P11	Medium
P12	High
P13	Medium
P14	High
P15	Low
P16	Medium
P17	Low
P18	Medium
P19	Low
P20	Medium

We can see that in case 2(a) the contamination level at P11 was recorded as low. Let us check all the option one by one.

(Option : A) The contamination level at P12 was recorded as high. This statement is incorrect as we can see in the table, the contamination level at P12 was recorded as medium.

(Option : B) The contamination level at P15 was recorded as medium. This statement is incorrect as we can see in the table, the contamination level at P15 was recorded as High.

(Option : C) The contamination level at P18 was recorded as low. This statement is incorrect as we can see in the table, the contamination level at P18 was recorded as Medium.

(Option : D) The contamination level at P14 was recorded as medium. This statement is correct as we can see in the table, the contamination level at P14 was recorded as Medium. Hence, we can say that option D is the correct answer.

50. If contamination level at P15 was recorded as medium, then which of the following MUST be FALSE?

- A Contamination levels at P13 and P17 were recorded as the same.
- B Contamination levels at P11 and P16 were recorded as the same.
- C Contamination level at P14 was recorded to be higher than that at P15.
- D Contamination levels at P10 and P14 were recorded as the same.

Answer: B

Explanation:

Let us draw the table and fill all absolute information present.

Pumps	Contamination level
P1	
P2	
P3	
P4	
P5	
P6	Low
P7	
P8	
P9	
P10	
P11	
P12	
P13	
P14	
P15	
P16	
P17	
P18	
P19	
P20	

In statement 3, it is given that P7 and P8 were the only two consecutively numbered pumps where the same levels of contamination were recorded.

In statement 1, it is given that contamination levels at three pumps among P1 - P5 were recorded as high. This is only possible when pumps 1, 3 and 5 have high level of contamination. Also, P6 was the only pump among P1 - P10 where the contamination level was recorded as low. Therefore, we can say that pumps 2 and 4 have medium level of contamination.

Pumps	Contamination level
P1	High
P2	Medium
P3	High
P4	Medium
P5	High
P6	Low
P7	
P8	
P9	
P10	
P11	
P12	
P13	
P14	
P15	
P16	
P17	
P18	
P19	
P20	

It is given that High contamination levels were not recorded at any of the pumps P16 - P20. Therefore, we can say that High contamination was recorded in only first 15 pumps. Therefore, we can say that the maximum number of pumps that can have high contamination level is '8'. (Consecutive pumps don't have same contamination level except one case)

Also, it is given that the number of pumps where high contamination levels were recorded was twice the number of pumps where low contamination levels were recorded. Hence, we can say that the number of pumps that have high contamination level is an even number less than or equal to '8'.

If the number of high contamination level pumps is '6', then there will be only '3' pumps with low contamination level. Consequently, we will need 11 (20 - 6 - 3) pumps with medium contamination level which is not possible since the number of pumps of a single type can't exceed 10. (Consecutive pumps don't have same contamination level except one case)

Therefore, we can say that the number of pumps that have high contamination level = 8

The number of pumps that have low contamination level = $8/2 = 4$

Also, the number of pumps that have medium contamination level = $20 - 8 - 4 = 12$

It is given that P7 and P8 were the only two consecutively numbered pumps where the same levels of contamination were recorded. If P7 and P8 recorded medium contamination level then there can be at max 7 pumps (P1, P3, P5, P9, P11, P13, P15) with high contamination level. Hence, we can say that pumps P7 and P8 recorded High contamination level. Therefore, we can uniquely determine the contamination level till P10.

Pumps	Contamination level
P1	High
P2	Medium
P3	High
P4	Medium
P5	High
P6	Low
P7	High
P8	High
P9	Medium
P10	High
P11	
P12	
P13	
P14	
P15	
P16	
P17	
P18	
P19	
P20	

It is given that High contamination levels were not recorded at any of the pumps P16 - P20. Therefore, we can say that these 5 pumps recorded low and medium contamination level. There are two cases possible.

Case 1: When there were 3 Low and 2 Medium contaminated level recorded in pumps P16 - P20.

3 Low contamination level must have recorded in P16, P18 and P20. We can fill the table as follows.

Pumps	Contamination level
P1	High
P2	Medium
P3	High
P4	Medium
P5	High
P6	Low
P7	High
P8	High
P9	Medium
P10	High
P11	Medium
P12	High
P13	Medium
P14	High
P15	Medium
P16	Low
P17	Medium
P18	Low
P19	Medium
P20	Low

Case 2: When there were 2 Low and 3 Medium contaminated level recorded in pumps P16 - P20.

3 Medium contamination level must have recorded in P16, P18 and P20. We can fill the table as follows.

Pumps	Contamination level
P1	High
P2	Medium
P3	High
P4	Medium
P5	High
P6	Low
P7	High
P8	High
P9	Medium
P10	High
P11	Low
P12	Medium
P13	High
P14	Medium
P15	High
P16	Medium
P17	Low
P18	Medium
P19	Low
P20	Medium

Pumps	Contamination level
P1	High
P2	Medium
P3	High
P4	Medium
P5	High
P6	Low
P7	High
P8	High
P9	Medium
P10	High
P11	Medium
P12	Low
P13	High
P14	Medium
P15	High
P16	Medium
P17	Low
P18	Medium
P19	Low
P20	Medium

Pumps	Contamination level
P1	High
P2	Medium
P3	High
P4	Medium
P5	High
P6	Low
P7	High
P8	High
P9	Medium
P10	High
P11	Medium
P12	High
P13	Low
P14	Medium
P15	High
P16	Medium
P17	Low
P18	Medium
P19	Low
P20	Medium

Pumps	Contamination level
P1	High
P2	Medium
P3	High
P4	Medium
P5	High
P6	Low
P7	High
P8	High
P9	Medium
P10	High
P11	Medium
P12	High
P13	Medium
P14	Low
P15	High
P16	Medium
P17	Low
P18	Medium
P19	Low
P20	Medium

Pumps	Contamination level
P1	High
P2	Medium
P3	High
P4	Medium
P5	High
P6	Low
P7	High
P8	High
P9	Medium
P10	High
P11	Medium
P12	High
P13	Medium
P14	High
P15	Low
P16	Medium
P17	Low
P18	Medium
P19	Low
P20	Medium

We can see that in case 1 the contamination level at P15 was recorded as medium. Let us check all the option one by one.

(Option :A) Contamination levels at P13 and P17 were recorded as the same. From the table, we can see that the contamination levels at P13 and P17 were recorded as medium. Hence, we can say that this statement is correct.

(Option :B) Contamination levels at P11 and P16 were recorded as the same. From the table, we can see that the contamination levels at P11 was recorded as Medium whereas at P16 it was recorded as Low. Hence, we can say that this statement is incorrect. Thus, option B is the correct answer.

Instructions [51 - 54]

The multi-layered pie-chart below shows the sales of LED television sets for a big retail electronics outlet during 2016 and 2017. The outer layer shows the monthly sales during this period, with each label showing the month followed by sales figure of that month. For some months, the sales figures are not given in the chart. The middle-layer shows quarterwise aggregate sales figures (in some cases, aggregate quarter-wise sales numbers are not given next to the quarter). The innermost layer shows annual sales. It is known that the sales figures during the three months of the second quarter (April, May, June) of 2016 form an arithmetic progression, as do the three monthly sales figures in the fourth quarter (October, November, December) of that year.

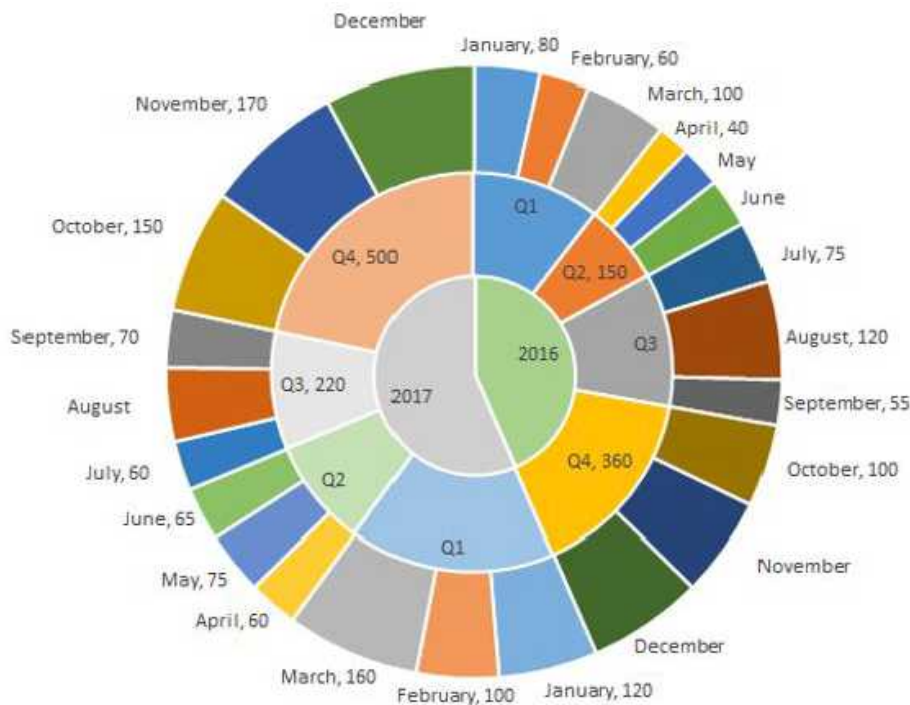

51. What is the percentage increase in sales in December 2017 as compared to the sales in December 2016?

- A 38.46
- B 22.22
- C 28.57
- D 50.00

Answer: C

Explanation: Sales in December 2016 = 140
Sales in December 2017 = 180

Percentage change = $(180-140)/140 = 40/140 = 28.57\%$

Therefore, option C is the right answer.

52. In which quarter of 2017 was the percentage increase in sales from the same quarter of 2016 the highest?

- A Q2
- B Q1
- C Q4
- D Q3

Answer: B

Explanation: Among the given 4 options, we have to find the quarter in which the increase in sale from the previous quarter was the highest.

Q2:

Sales in 2017 = 200

Sales in 2016 = 150

Q1:

Sales in 2017 = 380

Sales in 2016 = 240

Q3:

Sales in 2017 = 220

Sales in 2016 = 250

Q4:

Sales in 2017 = 500

Sales in 2016 = 360

We can eliminate Q3 since the sales has decreased.

Growth in Q2 sales = $50/150 = 1/3 = 33.33\%$

Growth in Q1 sales = $(380-240)/240 = 140/240 = 58.33\%$

Growth in Q4 sales = $(500-360)/360 = 140/360$

$140/240 > 140/360$

Therefore, Q1 has recorded the highest growth in sales and hence, option B is the right answer.

53. During which quarter was the percentage decrease in sales from the previous quarter's sales the highest?

- A Q2 of 2017
- B Q4 of 2017
- C Q2 of 2016
- D Q1 of 2017

Answer: A

Explanation: Q2 of 2017:

Sales in Q2 of 2017 = 200
Sales in Q1 of 2017 = 380
% decrease = $180/380$

Q4 of 2017:

We can eliminate this option since the sales has increased in Q4 of 2017 as compared to the previous quarter.

Q2 of 2016:

Sales in Q2 of 2016 = 150
Sales in Q1 of 2016 = 240
% decrease = $90/240$

Q1 of 2017:

Sales in Q1 of 2017 has increased as compared to sales in the previous quarter. We can eliminate this option as well.

$180/380$ is very close to 50%. $90/240$ is closer to 33.33%. Therefore, option A is the right answer.

54. During which month was the percentage increase in sales from the previous month's sales the highest?

- A March of 2017
- B October of 2017
- C March of 2016
- D October of 2016

Answer: B

Explanation: March of 2017:

Sales in March of 2017 = 160
Sales in February of 2017 = 100
% increase = $60/100 = 60\%$

October of 2017:

Sales in October of 2017 = 150
Sales in September of 2017 = 70

As we can see, the sales has increased by more than 100%.

March of 2016:

Sales in March of 2016 = 100
 Sales in February of 2016 = 60
 % increase in sales is less than 100%.

October of 2016:
 Sales in October of 2016 = 100
 Sales in September of 2016 = 55
 % increase is less than 100%

As we can see, the percentage increase in sale as compared to the previous month was highest in October of 2017 among the given options. Therefore, option B is the right answer.

Instructions [55 - 58]

Twenty four people are part of three committees which are to look at research, teaching, and administration respectively. No two committees have any member in common. No two committees are of the same size. Each committee has three types of people: bureaucrats, educationalists, and politicians, with at least one from each of the three types in each committee. The following facts are also known about the committees:

1. The numbers of bureaucrats in the research and teaching committees are equal, while the number of bureaucrats in the research committee is 75% of the number of bureaucrats in the administration committee.
2. The number of educationalists in the teaching committee is less than the number of educationalists in the research committee. The number of educationalists in the research committee is the average of the numbers of educationalists in the other two committees.
3. 60% of the politicians are in the administration committee, and 20% are in the teaching committee.

55. **Based on the given information, which of the following statements MUST be FALSE?**

- A** In the teaching committee the number of educationalists is equal to the number of politicians
- B** In the administration committee the number of bureaucrats is equal to the number of educationalists
- C** The size of the research committee is less than the size of the teaching committee
- D** The size of the research committee is less than the size of the administration committee

Answer: C

Explanation:

Let us draw a table according to the information given.

	Research	Teaching	Administration	Total
Bureaucrats				
Educationalists				
Politicians				
Total				24

It is given that the numbers of bureaucrats in the research and teaching committees are equal, while the number of bureaucrats in the research committee is 75% of the number of bureaucrats in the administration committee. Let '4x' be the number of bureaucrats in Administration committee.

	Research	Teaching	Administration	Total
Bureaucrats	3x	3x	4x	10x
Educationalists				
Politicians				
Total				24

The number of educationalists in the teaching committee is less than the number of educationalists in the research committee. The number of educationalists in the research committee is the average of the numbers of educationalists in the other two committees. Let us assume that 'y' is the number of educationalists in the research committee and 'd' be the difference in the number of educationalists in Research and teaching committees.

	Research	Teaching	Administration	Total
Bureaucrats	3x	3x	4x	10x
Educationalists	y	y-d	y+d	3y
Politicians				
Total				24

60% of the politicians are in the administration committee, and 20% are in the teaching committee. Let '5z' be the number of total number of politicians.

	Research	Teaching	Administration	Total
Bureaucrats	3x	3x	4x	10x
Educationalists	y	y-d	y+d	3y
Politicians	z	z	3z	5z
Total				24

We can say that

$$\Rightarrow 10x+3y+5z = 24$$

We can see that each of x, y and z has to a natural number integer. If $x > 1$, then both y and z can't take any natural number.

Hence, we can say that $x = 1$.

At $x = 1$, $3y+5z = 14$. If $y = 1$ or 2 , Z is not an integer.

At $x = 1$ and $y = 3$, $z = 1$ which is the only possible solution.

	Research	Teaching	Administration	Total
Bureaucrats	3	3	4	10
Educationalists	3	3-d	3+d	9
Politicians	1	1	3	5
Total				24

We can see that 'd' can assume two possible values. $d = 1$ or 2 .

	Research	Teaching	Administration	Total
Bureaucrats	3	3	4	10
Educationalists	3	2/1	4/5	9
Politicians	1	1	3	5
Total	7	6/5	11/12	24

Let us check the option one by one.

Option A: In the teaching committee the number of educationalists is equal to the number of politicians. We can see that in the teaching committee the number of educationalists can be equal to the number of politicians when both the numbers are '1'. Hence, this statement can be correct.

Option B: In the administration committee the number of bureaucrats is equal to the number of educationalists. We can see that in the administration committee the number of bureaucrats can be equal to the number of educationalists when both the numbers are '4'. Hence, this statement can be correct.

Option C: The size of the research committee is less than the size of the teaching committee. We can see the maximum size of teaching committee can be '6' which is less than the size of the research committee. Hence, the sentence is incorrect.

Option D: The size of the research committee is less than the size of the administration committee. We can see the minimum size of Administration committee can be '9' which is more than the size of the research committee. Hence, this statement is correct.

Therefore, we can say that option C is the correct answer.

56. What is the number of bureaucrats in the administration committee?

Answer:4

Explanation:

Let us draw a table according to the information given.

	Research	Teaching	Administration	Total
Bureaucrats				
Educationalists				
Politicians				
Total				24

It is given that the numbers of bureaucrats in the research and teaching committees are equal, while the number of bureaucrats in the research committee is 75% of the number of bureaucrats in the administration committee. Let '4x' be the number of bureaucrats in Administration committee.

	Research	Teaching	Administration	Total
Bureaucrats	3x	3x	4x	10x
Educationalists				
Politicians				
Total				24

The number of educationalists in the teaching committee is less than the number of educationalists in the research committee. The number of educationalists in the research committee is the average of the numbers of educationalists in the other two committees. Let us assume that 'y' is the number of educationalists in the research committee and 'd' be the difference in the number of educationalists in Research and teaching committees.

	Research	Teaching	Administration	Total
Bureaucrats	3x	3x	4x	10x
Educationalists	y	y-d	y+d	3y
Politicians				
Total				24

60% of the politicians are in the administration committee, and 20% are in the teaching committee. Let '5z' be the number of total number of politicians.

	Research	Teaching	Administration	Total
Bureaucrats	3x	3x	4x	10x
Educationalists	y	y-d	y+d	3y
Politicians	z	z	3z	5z
Total				24

We can say that

$$\Rightarrow 10x+3y+5z = 24$$

We can see that each of x, y and z has to a natural number integer. If $x > 1$, then both y and z can't take any natural number.

Hence, we can say that $x = 1$.

At $x = 1$, $3y+5z = 14$. If $y = 1$ or 2, Z is not an integer.

At $x = 1$ and $y = 3$, $z = 1$ which is the only possible solution.

	Research	Teaching	Administration	Total
Bureaucrats	3	3	4	10
Educationalists	3	3-d	3+d	9
Politicians	1	1	3	5
Total				24

We can see that 'd' can assume two possible values. $d = 1$ or 2 .

	Research	Teaching	Administration	Total
Bureaucrats	3	3	4	10
Educationalists	3	2/1	4/5	9
Politicians	1	1	3	5
Total	7	6/5	11/12	24

From the table, we can see that the number of bureaucrats in the administration committee = 4.

57. What is the number of educationalists in the research committee?

Answer:3

Explanation:

Let us draw a table according to the information given.

	Research	Teaching	Administration	Total
Bureaucrats				
Educationalists				
Politicians				
Total				24

It is given that the numbers of bureaucrats in the research and teaching committees are equal, while the number of bureaucrats in the research committee is 75% of the number of bureaucrats in the administration committee. Let ' $4x$ ' be the number of bureaucrats in Administration committee.

	Research	Teaching	Administration	Total
Bureaucrats	3x	3x	4x	10x
Educationalists				
Politicians				
Total				24

The number of educationalists in the teaching committee is less than the number of educationalists in the research committee. The number of educationalists in the research committee is the average of the numbers of educationalists in the other two committees. Let us assume that ' y ' is the number of educationalists in the research committee and ' d ' be the difference in the number of educationalists in Research and teaching committees.

	Research	Teaching	Administration	Total
Bureaucrats	3x	3x	4x	10x
Educationalists	y	y-d	y+d	3y
Politicians				
Total				24

60% of the politicians are in the administration committee, and 20% are in the teaching committee. Let '5z' be the number of total number of politicians.

	Research	Teaching	Administration	Total
Bureaucrats	3x	3x	4x	10x
Educationalists	y	y-d	y+d	3y
Politicians	z	z	3z	5z
Total				24

We can say that

$$\Rightarrow 10x+3y+5z = 24$$

We can see that each of x, y and z has to a natural number integer. If $x > 1$, then both y and z can't take any natural number.

Hence, we can say that $x = 1$.

At $x = 1$, $3y+5z = 14$. If $y = 1$ or 2 , Z is not an integer.

At $x = 1$ and $y = 3$, $z = 1$ which is the only possible solution.

	Research	Teaching	Administration	Total
Bureaucrats	3	3	4	10
Educationalists	3	3-d	3+d	9
Politicians	1	1	3	5
Total				24

We can see that 'd' can assume two possible values. $d = 1$ or 2 .

	Research	Teaching	Administration	Total
Bureaucrats	3	3	4	10
Educationalists	3	2/1	4/5	9
Politicians	1	1	3	5
Total	7	6/5	11/12	24

From the table, we can see that the number of educationalists in the research committee = 3.

58. Which of the following CANNOT be determined uniquely based on the given information?

- A The size of the teaching committee
- B The size of the research committee
- C The total number of bureaucrats in the three committees
- D The total number of educationalists in the three committees

Answer: A

Explanation:

Let us draw a table according to the information given.

	Research	Teaching	Administration	Total
Bureaucrats				
Educationalists				
Politicians				
Total				24

It is given that the numbers of bureaucrats in the research and teaching committees are equal, while the number of bureaucrats in the research committee is 75% of the number of bureaucrats in the administration committee. Let '4x' be the number of bureaucrats in Administration committee.

	Research	Teaching	Administration	Total
Bureaucrats	3x	3x	4x	10x
Educationalists				
Politicians				
Total				24

The number of educationalists in the teaching committee is less than the number of educationalists in the research committee. The number of educationalists in the research committee is the average of the numbers of educationalists in the other two committees. Let us assume that 'y' is the number of educationalists in the research committee and 'd' be the difference in the number of educationalists in Research and teaching committees.

	Research	Teaching	Administration	Total
Bureaucrats	3x	3x	4x	10x
Educationalists	y	y-d	y+d	3y
Politicians				
Total				24

60% of the politicians are in the administration committee, and 20% are in the teaching committee. Let '5z' be the number of total number of politicians.

	Research	Teaching	Administration	Total
Bureaucrats	3x	3x	4x	10x
Educationalists	y	y-d	y+d	3y
Politicians	z	z	3z	5z
Total				24

We can say that

$$\Rightarrow 10x+3y+5z = 24$$

We can see that each of x, y and z has to a natural number integer. If $x > 1$, then both y and z can't take any natural number.

Hence, we can say that $x = 1$.

At $x = 1$, $3y+5z = 14$. If $y = 1$ or 2 , Z is not an integer.

At $x = 1$ and $y = 3$, $z = 1$ which is the only possible solution.

	Research	Teaching	Administration	Total
Bureaucrats	3	3	4	10
Educationalists	3	3-d	3+d	9
Politicians	1	1	3	5
Total				24

We can see that 'd' can assume two possible values. $d = 1$ or 2 .

	Research	Teaching	Administration	Total
Bureaucrats	3	3	4	10
Educationalists	3	2/1	4/5	9
Politicians	1	1	3	5
Total	7	6/5	11/12	24

From the table, we can not uniquely determine the size of the teaching committee. Hence, option A is the correct answer.

Instructions [59 - 62]

1600 satellites were sent up by a country for several purposes. The purposes are classified as broadcasting (B), communication (C), surveillance (S), and others (O). A satellite can serve multiple purposes; however a satellite serving either B, or C, or S does not serve O. The following facts are known about the satellites:

1. The numbers of satellites serving B, C, and S (though may be not exclusively) are in the ratio 2:1:1.
2. The number of satellites serving all three of B, C, and S is 100.
3. The number of satellites exclusively serving C is the same as the number of satellites exclusively serving S. This number is 30% of the number of satellites exclusively serving B.
4. The number of satellites serving O is the same as the number of satellites serving both C and S but not B.

59. **What best can be said about the number of satellites serving C?**

- A** Must be at least 100
- B** Cannot be more than 800
- C** Must be between 450 and 725
- D** Must be between 400 and 800

Answer: C

Explanation: br/>

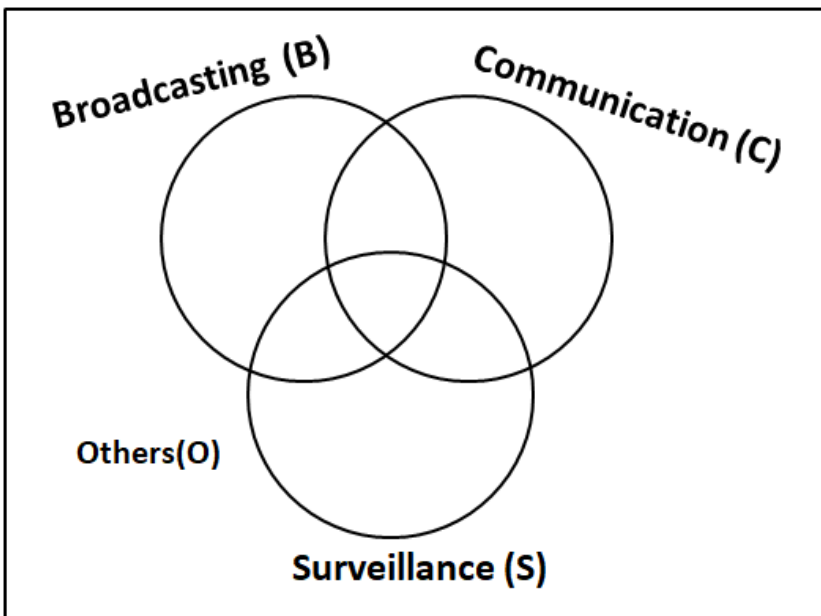

1. The numbers of satellites serving B, C, and S (though may be not exclusively) are in the ratio 2:1:1.

2. The number of satellites serving all three of B, C, and S is 100.
3. The number of satellites exclusively serving C is the same as the number of satellites exclusively serving S. This number is 30% of the number of satellites exclusively serving B.
4. The number of satellites serving O is the same as the number of satellites serving both C and S but not B.

Let '10x' be the number of satellites exclusively serving B. Then, the number of satellites exclusively serving C and S = $0.30 \cdot 10x = 3x$

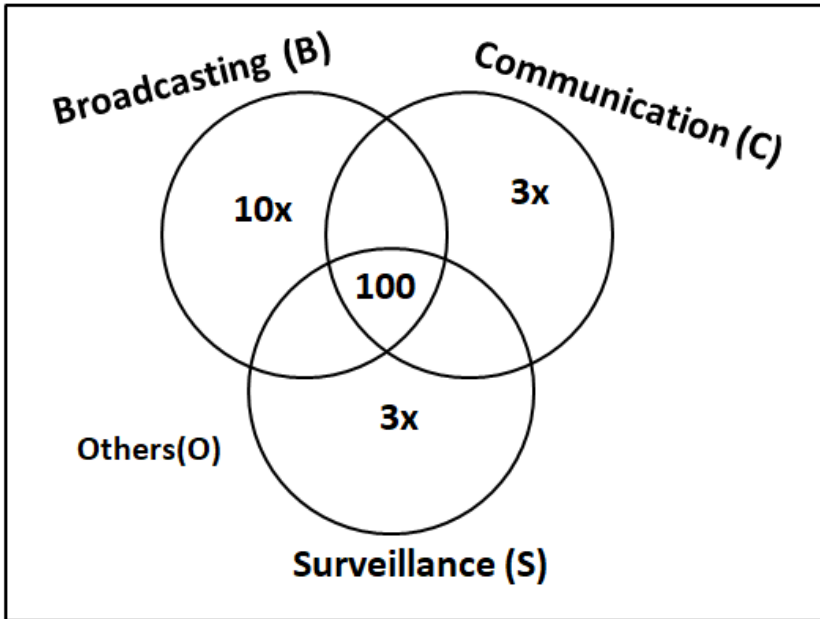

Let 'y' be the number of satellites serving others(O).

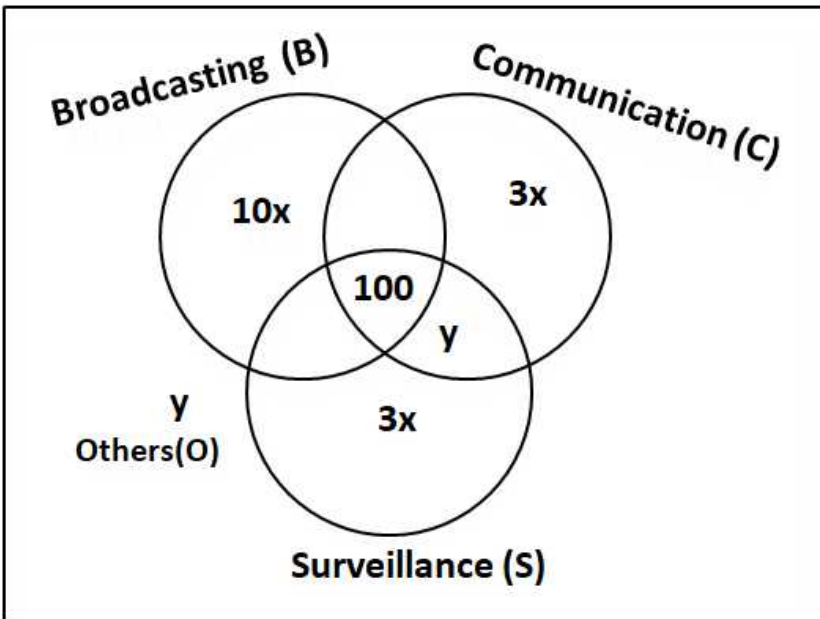

Let 'z' be the number of satellites serving B, C but not S. Since the numbers of satellites serving B, C, and S (though may be not exclusively) are in the ratio 2:1:1. Therefore, we can say that number of satellites serving B, S but not C = z.

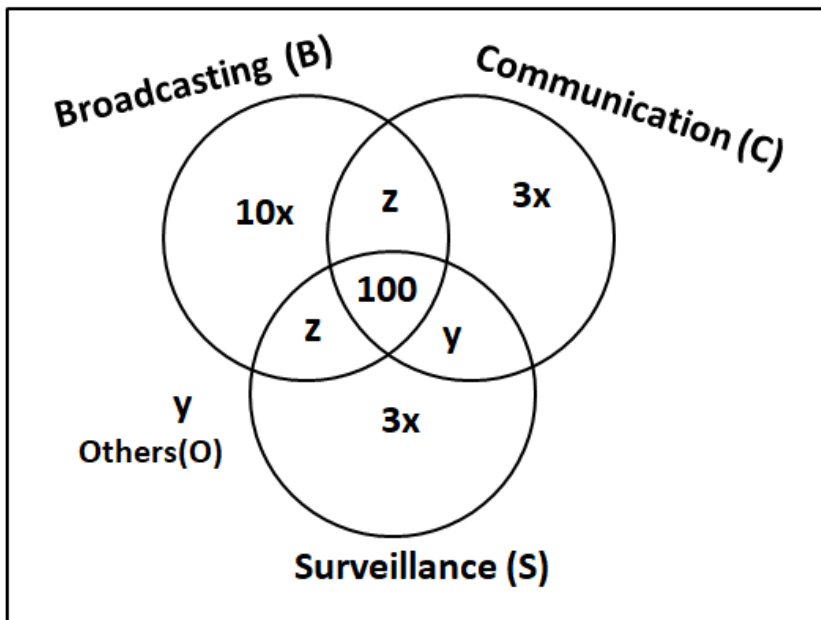

It is given that

$$\Rightarrow 10x + 2z + 2y + 6x = 1600$$

$$\Rightarrow 8x + z + y = 750 \dots (1)$$

The numbers of satellites serving B, C, and S (though may be not exclusively) are in the ratio 2:1:1.

$$\frac{10x + 2z + 100}{z + 100 + 3x + y} = 2$$

$$\Rightarrow 10x + 2z + 100 = 2(z + 100 + 3x + y)$$

$$\Rightarrow 4x = 100 + 2y$$

$$\Rightarrow 2x = 50 + y$$

$$\Rightarrow y = 2x - 50 \dots (2)$$

We can substitute this in equation (1)

$$\Rightarrow 8x + z + 2x - 50 = 750$$

$$\Rightarrow z = 800 - 10x \dots (3)$$

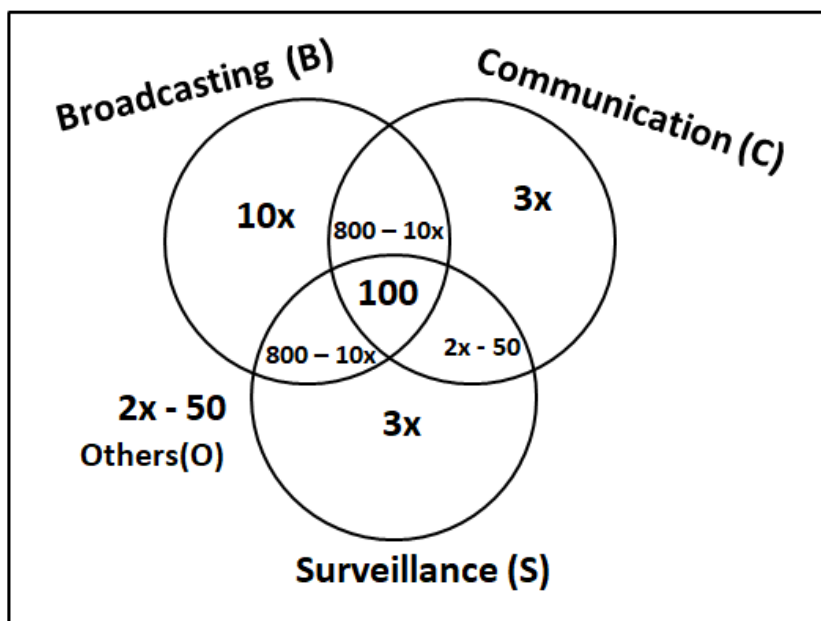

Let us define boundary condition for x,

$$\Rightarrow 2x - 50 \geq 0$$

$$\Rightarrow x \geq 25$$

Also, $800 - 10x \geq 0$

$\Rightarrow x \leq 80$

Therefore, we can say that $x \in [25, 80]$.

The number of satellites serving C = $800 - 10x + 100 + 3x + 2x - 50 = 850 - 5x$

At $x = 25$, The number of satellites serving C = $850 - 5x = 850 - 5 \cdot 25 = 725$

At $x = 80$, The number of satellites serving C = $850 - 5x = 850 - 5 \cdot 80 = 450$

Hence, we can say that the number of satellites serving C must be between 450 and 725. Hence, option C is the correct answer.

60. What is the minimum possible number of satellites serving B exclusively?

A 250

B 100

C 500

D 200

Answer: A

Explanation:

It is given that a satellite serving either B, or C, or S does not serve O. So we can say that it's basically 3 satellites broadcasting (B), communication (C), surveillance (S) which can have intersections. Those satellites which are not part of any category are placed in others. We can draw the Venn diagram as follows.

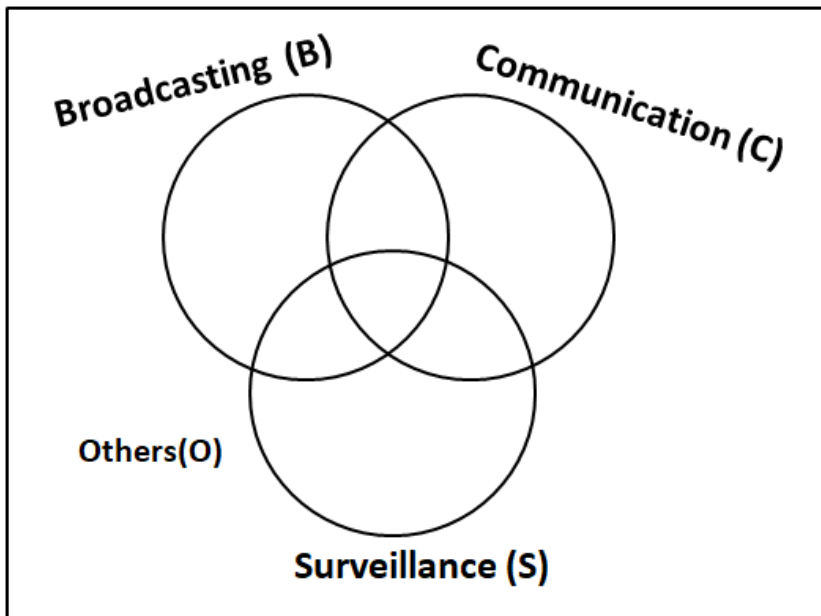

1. The numbers of satellites serving B, C, and S (though may be not exclusively) are in the ratio 2:1:1. 2. The number of satellites serving all three of B, C, and S is 100. 3. The number of satellites exclusively serving C is the same as the number of satellites exclusively serving S. This number is 30% of the number of satellites exclusively serving B. 4. The number of satellites serving O is the same as the number of satellites serving both C and S but not B.

Let '10x' be the number of satellites exclusively serving B. Then, the number of satellites exclusively serving C and S = $0.30 \cdot 10x = 3x$

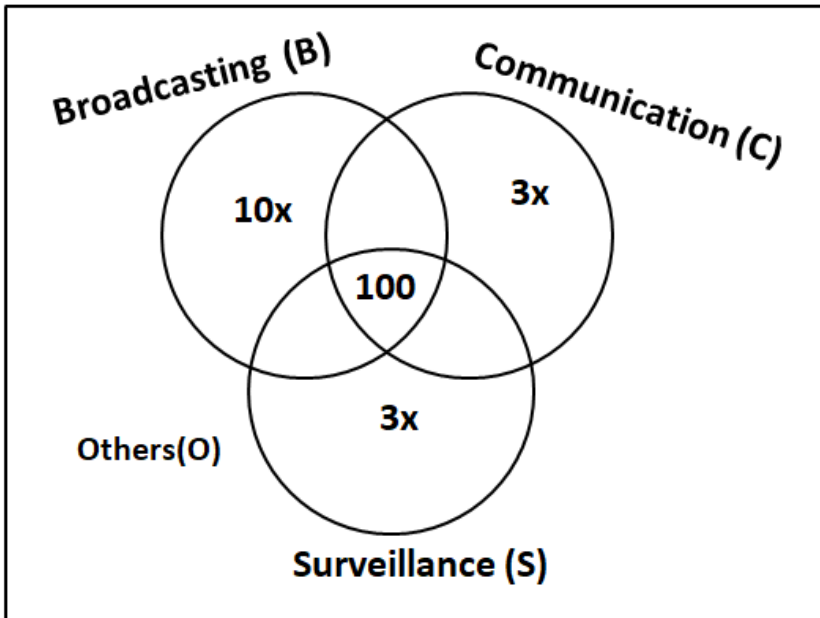

Let 'y' be the number of satellites serving others(O).

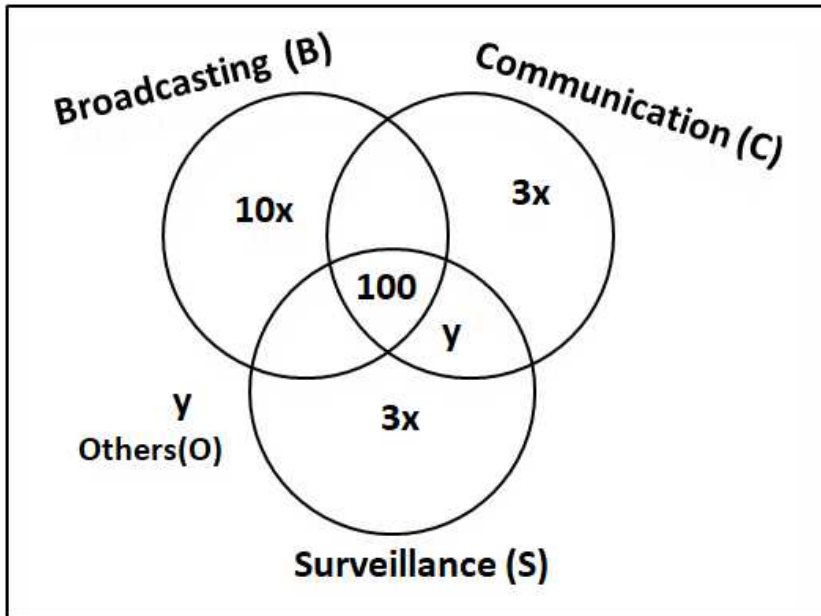

Let 'z' be the number of satellites serving B, C but not S. Since the numbers of satellites serving B, C, and S (though may be not exclusively) are in the ratio 2:1:1. Therefore, we can say that number of satellites serving B, S but not C = z.

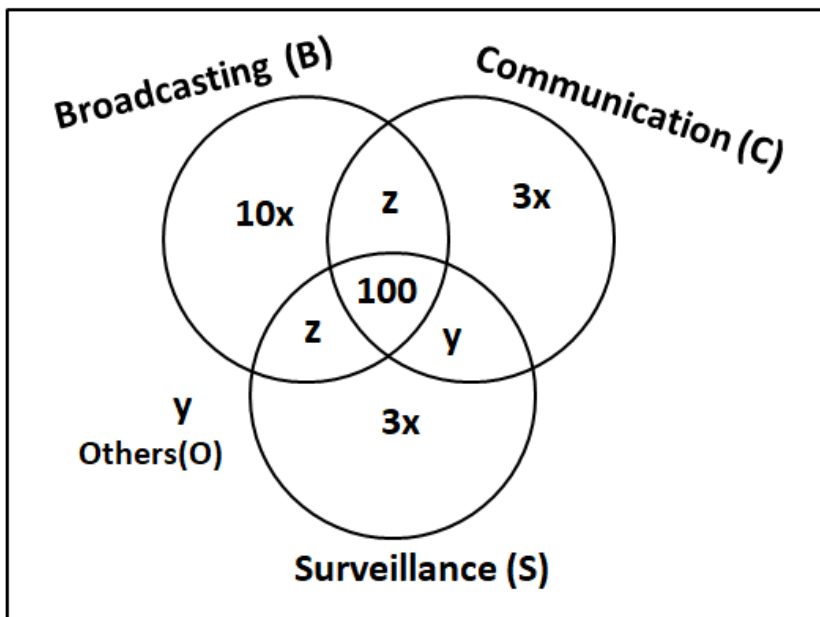

It is given that

$$\Rightarrow 10x + 2z + 2y + 6x = 1600$$

$$\Rightarrow 8x + z + y = 750 \dots (1)$$

The numbers of satellites serving B, C, and S (though may be not exclusively) are in the ratio 2:1:1.

$$10x + 2z + 100 = 2(z + 100 + 3x + y)$$

$$\Rightarrow z + 100 + 3x + y = 100$$

$$\Rightarrow 10x + 2z + 100 = 2(z + 100 + 3x + y)$$

$$\Rightarrow 4x = 100 + 2y$$

$$\Rightarrow 2x = 50 + y$$

$$\Rightarrow y = 2x - 50 \dots (2)$$

We can substitute this in equation (1)

$$\Rightarrow 8x + z + 2x - 50 = 750$$

$$\Rightarrow z = 800 - 10x \dots (3)$$

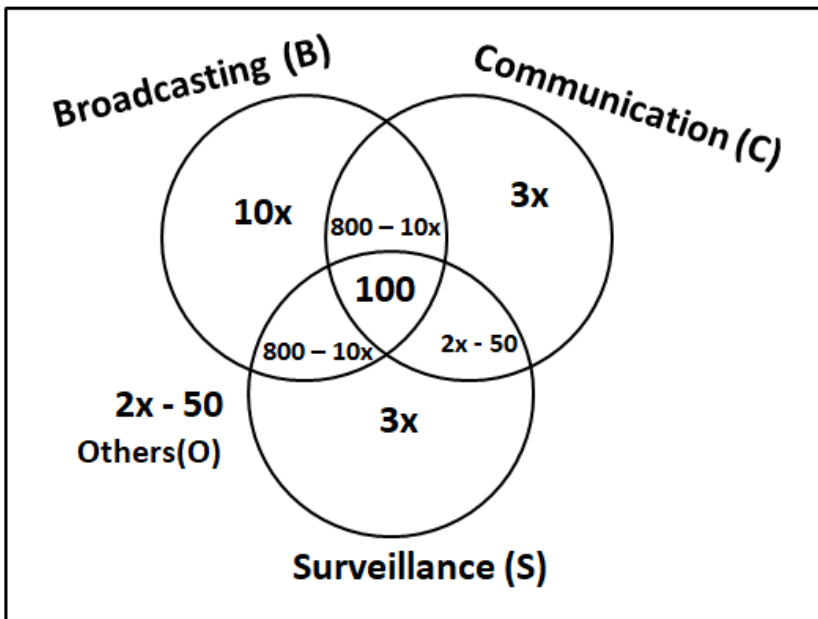

Let us define boundary condition for x ,

$$\Rightarrow 2x - 50 \geq 0$$

$$\Rightarrow x \geq 25$$

Also, $800 - 10x \geq 0$

$$\Rightarrow x \leq 80$$

Therefore, we can say that $x \in [25, 80]$.

The number of satellites serving B exclusively = $10x$. This will be minimum when ' x ' is minimum.

At $x_{min} = 25$, The number of satellites serving B exclusively = $10 \times 25 = 250$. Hence, option A is the correct answer.

61. If at least 100 of the 1600 satellites were serving O, what can be said about the number of satellites serving S?

- A At most 475
- B Exactly 475
- C No conclusion is possible based on the given information
- D At least 475

Answer: A

Explanation: /p>

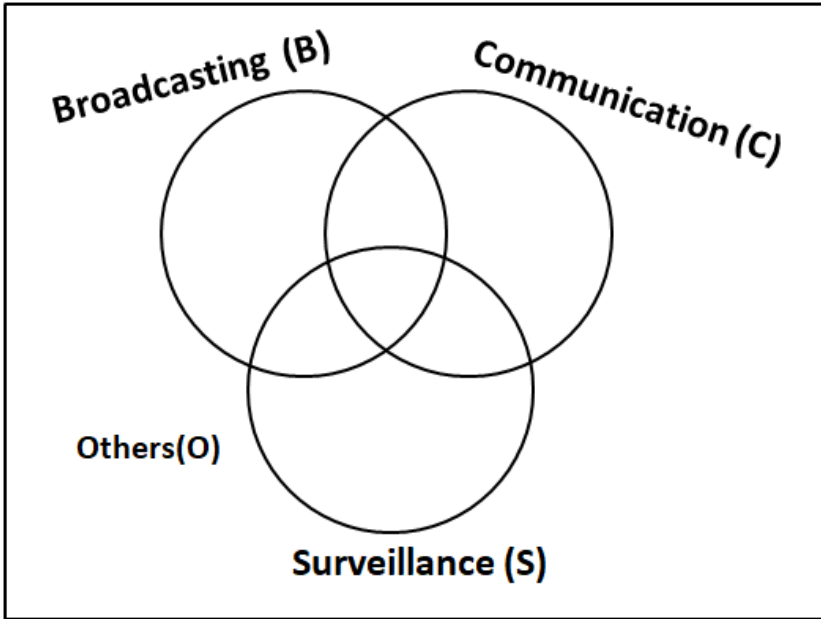

1. The numbers of satellites serving B, C, and S (though may be not exclusively) are in the ratio 2:1:1. 2. The number of satellites serving all three of B, C, and S is 100. 3. The number of satellites exclusively serving C is the same as the number of satellites exclusively serving S. This number is 30% of the number of satellites exclusively serving B. 4. The number of satellites serving O is the same as the number of satellites serving both C and S but not B.

Let '10x' be the number of satellites exclusively serving B. Then, the number of satellites exclusively serving C and S = $0.30 \cdot 10x = 3x$

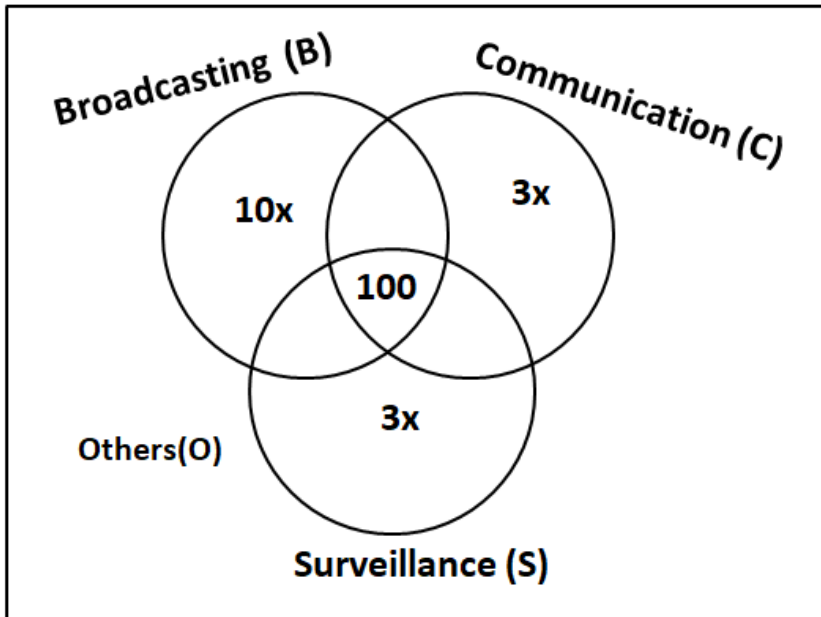

Let 'y' be the number of satellites serving others(O).

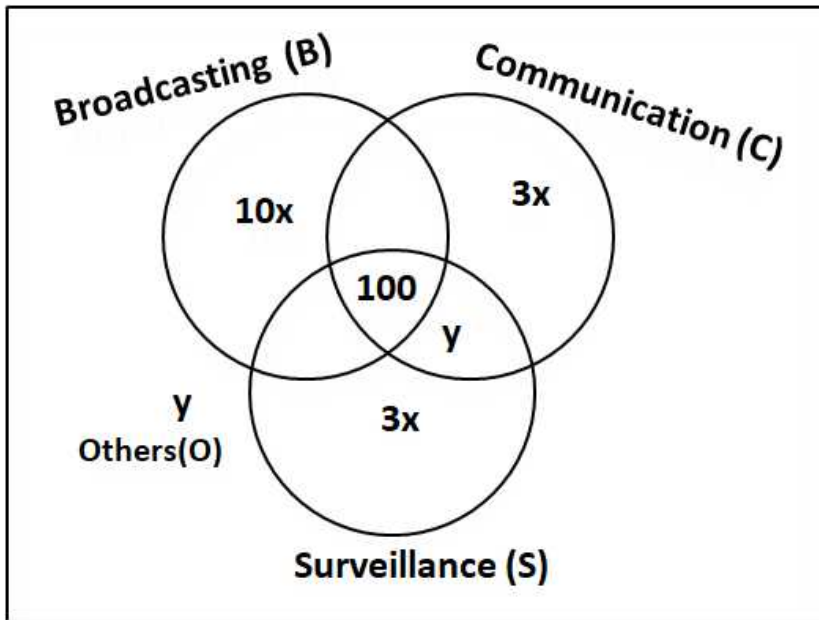

Let 'z' be the number of satellites serving B, C but not S. Since the numbers of satellites serving B, C, and S (though may be not exclusively) are in the ratio 2:1:1. Therefore, we can say that number of satellites serving B, S but not C = z.

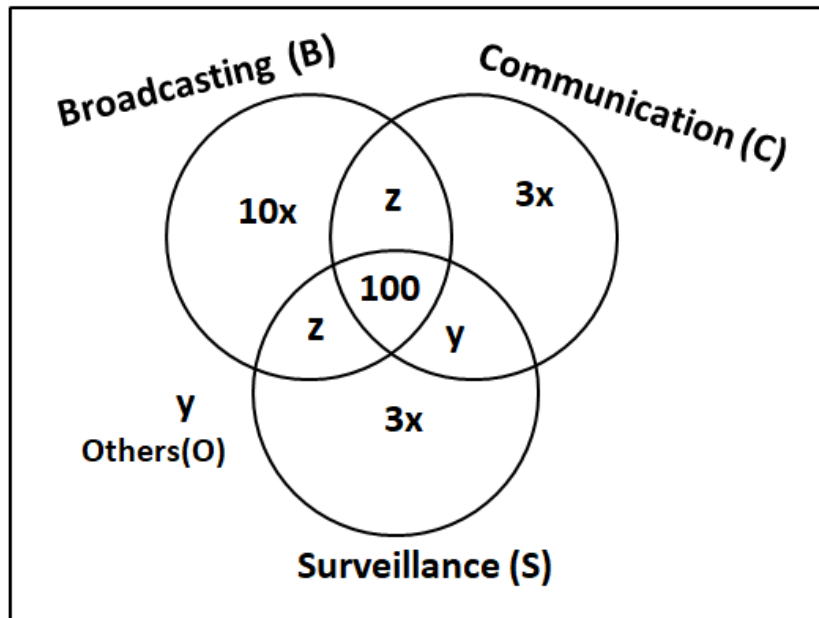

It is given that

$$\Rightarrow 10x + 2z + 2y + 6x = 1600$$

$$\Rightarrow 8x + z + y = 750 \dots (1)$$

The numbers of satellites serving B, C, and S (though may be not exclusively) are in the ratio 2:1:1.

$$\begin{aligned} & 10x + 2z + 100 = 2(z + 100 + 3x + y) \\ \Rightarrow & z + 100 + 3x + y = 100 \end{aligned}$$

$$\Rightarrow 10x + 2z + 100 = 2(z + 100 + 3x + y)$$

$$\Rightarrow 4x = 100 + 2y$$

$$\Rightarrow 2x = 50 + y$$

$$\Rightarrow y = 2x - 50 \dots (2)$$

We can substitute this in equation (1)

$$\Rightarrow 8x + z + 2x - 50 = 750$$

$$\Rightarrow z = 800 - 10x \dots (3)$$

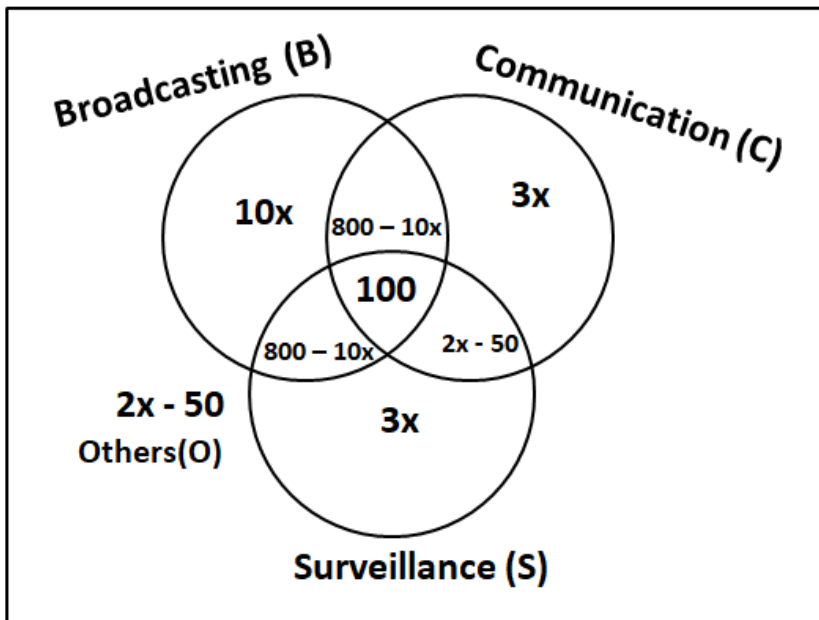

Let us define boundary condition for x,

$$\Rightarrow 2x - 50 \geq 0$$

$$\Rightarrow x \geq 25$$

Also, $800 - 10x \geq 0$

$$\Rightarrow x \leq 80$$

Therefore, we can say that $x \in [25, 80]$.

It is given that at least 100 of the 1600 satellites were serving O.

$$\Rightarrow 2x - 50 \geq 100$$

$$\Rightarrow x \geq 75$$

The number of satellites serving S = $100 + 800 - 10x + 2x - 50 + 3x = 850 - 5x$

At $x_{min} = 75$, the number of satellites serving S = $850 - 5 \cdot 75 = 475$

At $x_{max} = 80$, the number of satellites serving S = $850 - 5 \cdot 80 = 450$

Hence, we can say that the number of satellites serving S must be from 425 to 475. Therefore, we can say that option A is the correct answer.

62. If the number of satellites serving at least two among B, C, and S is 1200, which of the following MUST be FALSE?

- A The number of satellites serving B exclusively is exactly 250
- B The number of satellites serving B is more than 1000
- C The number of satellites serving C cannot be uniquely determined
- D All 1600 satellites serve B or C or S

Answer: C

Explanation: /p>

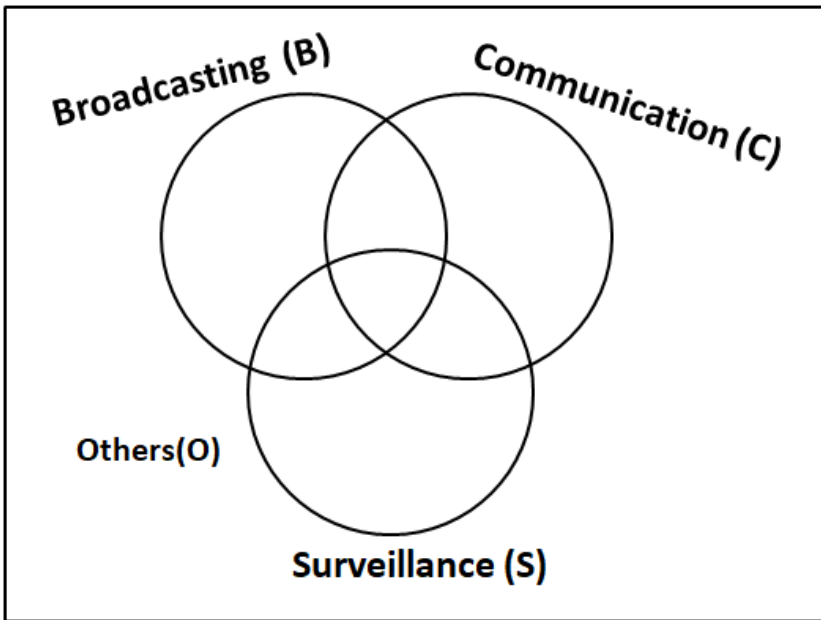

1. The numbers of satellites serving B, C, and S (though may be not exclusively) are in the ratio 2:1:1. 2. The number of satellites serving all three of B, C, and S is 100. 3. The number of satellites exclusively serving C is the same as the number of satellites exclusively serving S. This number is 30% of the number of satellites exclusively serving B. 4. The number of satellites serving O is the same as the number of satellites serving both C and S but not B.

Let '10x' be the number of satellites exclusively serving B. Then, the number of satellites exclusively serving C and S = $0.30 \cdot 10x = 3x$

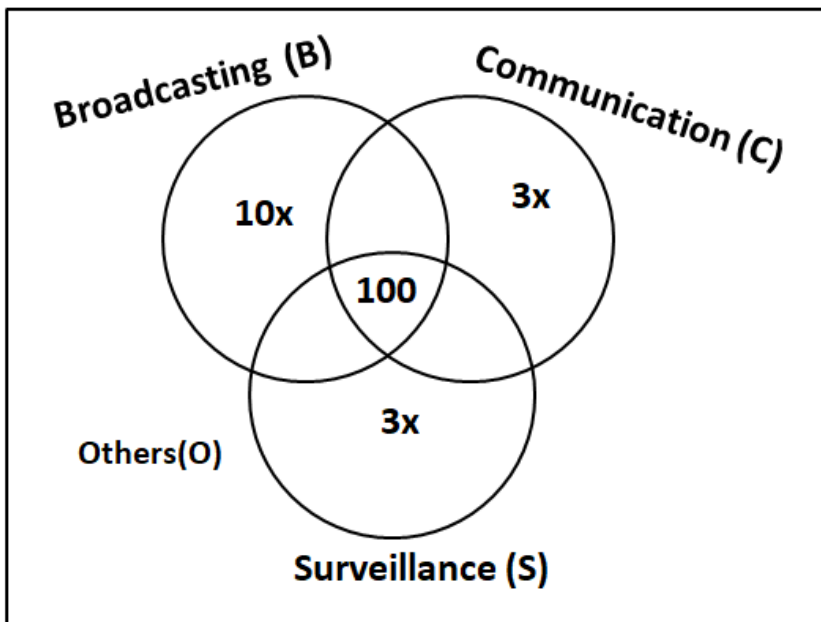

Let 'y' be the number of satellites serving others(O).

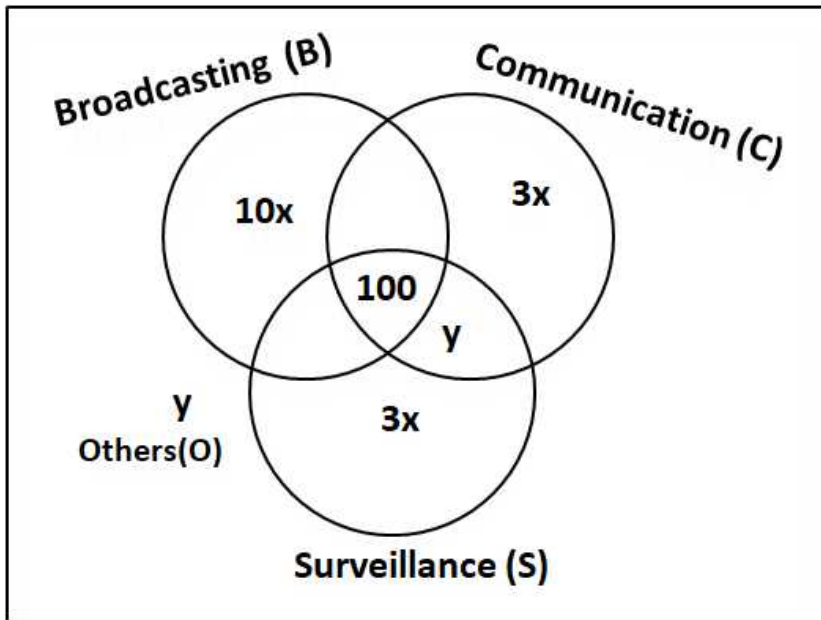

Let 'z' be the number of satellites serving B, C but not S. Since the numbers of satellites serving B, C, and S (though may be not exclusively) are in the ratio 2:1:1. Therefore, we can say that number of satellites serving B, S but not C = z.

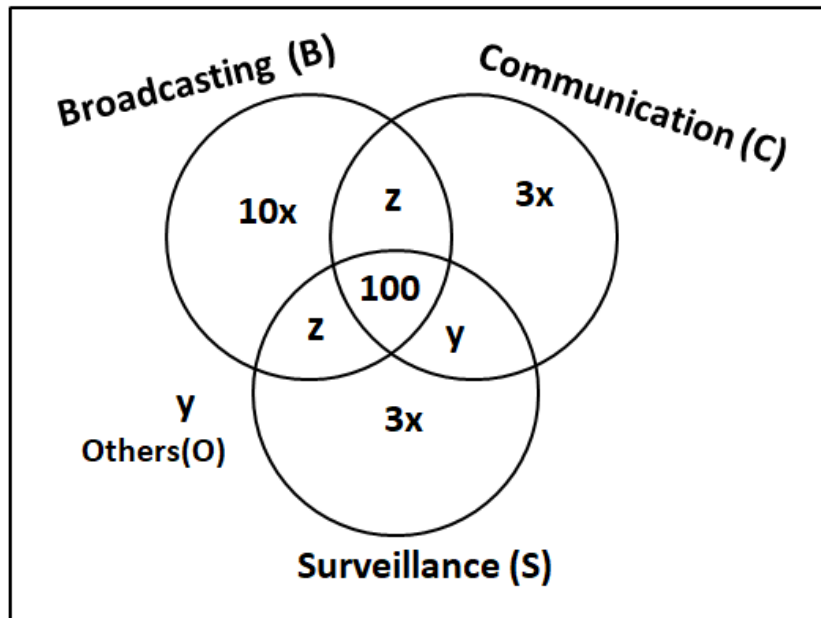

It is given that

$$\Rightarrow 10x + 2z + 2y + 6x = 1600$$

$$\Rightarrow 8x + z + y = 750 \dots (1)$$

The numbers of satellites serving B, C, and S (though may be not exclusively) are in the ratio 2:1:1.

$$\begin{aligned} & 10x + 2z + 100 = 2(z + 100 + 3x + y) \\ \Rightarrow & z + 100 + 3x + y = 100 \end{aligned}$$

$$\Rightarrow 10x + 2z + 100 = 2(z + 100 + 3x + y)$$

$$\Rightarrow 4x = 100 + 2y$$

$$\Rightarrow 2x = 50 + y$$

$$\Rightarrow y = 2x - 50 \dots (2)$$

We can substitute this in equation (1)

$$\Rightarrow 8x + z + 2x - 50 = 750$$

$$\Rightarrow z = 800 - 10x \dots (3)$$

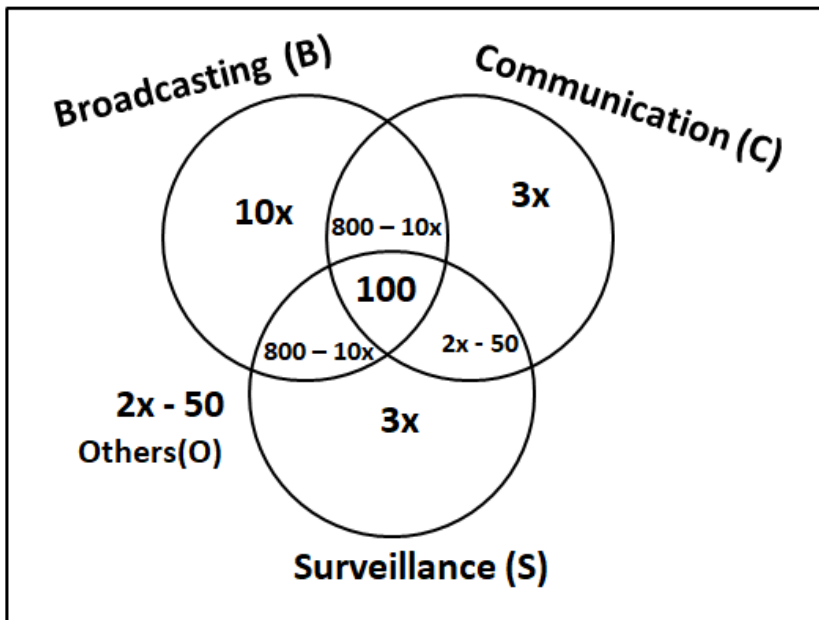

Let us define boundary condition for x ,

$$\Rightarrow 2x - 50 \geq 0$$

$$\Rightarrow x \geq 25$$

Also, $800 - 10x \geq 0$

$$\Rightarrow x \leq 80$$

Therefore, we can say that $x \in [25, 80]$.

It is given that the number of satellites serving at least two among B, C, and S is 1200.

$$\Rightarrow 800 - 10x + 800 - 10x + 2x - 50 + 100 = 1200$$

$$\Rightarrow 18x = 450$$

$$\Rightarrow x = 25$$

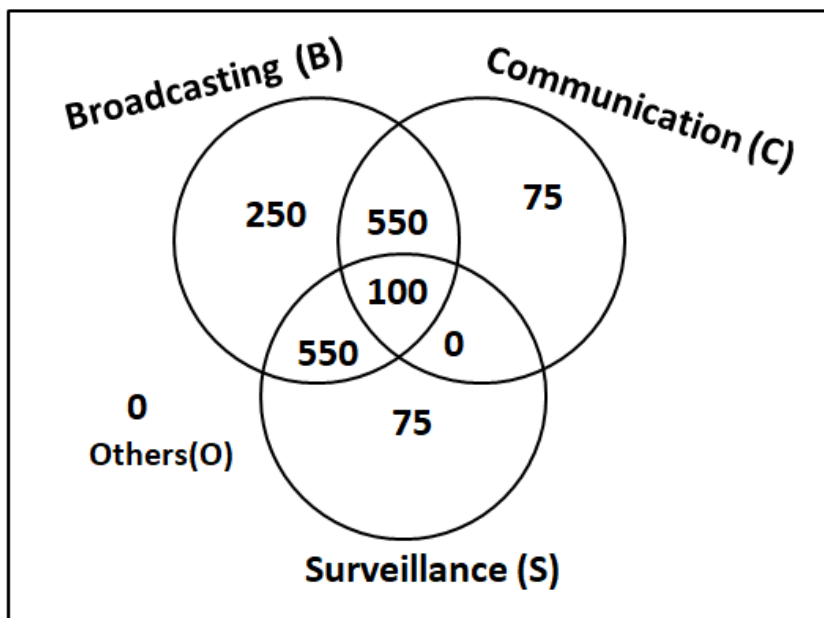

We can determine number of satellites in each of the following category. Hence, option C is definitely false. Therefore, we can say that option C is incorrect.

Instructions [63 - 66]

A company administers a written test comprising of three sections of 20 marks each - Data Interpretation (DI), Written English (WE) and General Awareness (GA), for recruitment. A composite score for a candidate (out of 80) is calculated by doubling her marks in DI and

adding it to the sum of her marks in the other two sections. Candidates who score less than 70% marks in two or more sections are disqualified. From among the rest, the four with the highest composite scores are recruited. If four or less candidates qualify, all who qualify are recruited.

Ten candidates appeared for the written test. Their marks in the test are given in the table below. Some marks in the table are missing, but the following facts are known:

1. No two candidates had the same composite score.
2. Ajay was the unique highest scorer in WE.
3. Among the four recruited, Geeta had the lowest composite score.
4. Indu was recruited.
5. Danish, Harini, and Indu had scored the same marks the in GA.
6. Indu and Jatin both scored 100% in exactly one section and Jatin's composite score was 10 more than Indu's.

Candidate	Marks out of 20		
	DI	WE	GA
Ajay	8		16
Bala		9	11
Chetna	19	4	12
Danish	8	15	
Ester	12	18	16
Falak	15	7	10
Geeta	14		6
Harini	5		
Indu		8	
Jatin		16	14

63. Which of the following statements **MUST** be true?
1. Jatin's composite score was more than that of Danish.
 2. Indu scored less than Chetna in DI.
 3. Jatin scored more than Indu in GA.

- A** Both 2 and 3
- B** Only 1
- C** Only 2
- D** Both 1 and 2

Answer: D

Explanation:

Statement 1: Jatin's composite score was more than that of Danish. We can see that this statement is correct.

Statement 2: Indu scored less than Chetna in DI. We can see that Indu scored 16 marks in DI whereas Chetna scored 19 marks in DI. Hence, we can say that this statement is also correct.

Statement 3: Jatin scored more than Indu in GA. We can see that Jatin scored 14 marks in GA whereas Indu scored 20 marks in GA. Hence, we can say that this statement is incorrect.

Hence, we can say that option D is the correct answer.

64. Which of the following statements **MUST** be FALSE?

- A** Bala scored same as Jatin in DI
- B** Harini's composite score was less than that of Falak
- C** Bala's composite score was less than that of Ester

D Chetna scored more than Bala in DI

Answer: A

Explanation:

Option A: Bala scored same as Jatin in DI. We can say that Bala scored 20 marks in DI. In that Bala's composite score = $2 \times 20 + 9 + 11 = 60$ which is same as Indu's composite score. Therefore, we can say that this is a false statement. Hence, option A is the correct answer.

65. **If all the candidates except Ajay and Danish had different marks in DI, and Bala's composite score was less than Chetna's composite score, then what is the maximum marks that Bala could have scored in DI?**

Answer:13

Explanation: It is given that all the candidates except Ajay and Danish had different marks in DI and Bala's composite score was less than Chetna's composite score.

Let us assume that Bala scored 'x' marks in DI.

$$\Rightarrow 2x + 9 + 11 < 54$$

$$\Rightarrow x < 17$$

We can see that Bala's score will be less than 17. Bala's maximum score in DI will be the largest possible number less than 17 which is not same as any other candidate's score in DI. From the table we can see that 16, 15 and 14 are already taken by Indu, Falak and Geeta respectively.

Therefore, we can say that Bala can score a maximum of 13 marks in DI.

66. **If all the candidates scored different marks in WE then what is the maximum marks that Harini could have scored in WE?**

Answer:14

Explanation:

Case 1: Geeta scored 19 marks in WE.

We can say that if Geeta scored 19 marks in WE, then Ajay scored 20 marks in DI. In that case Ajay's composite score = $2 \times 8 + 20 + 16 = 52$. Which is a possible case.

Case 2: Geeta scored 18 marks in WE.

We can say that if Geeta scored 18 marks in WE, then Ajay can score either 19 or 20 marks in DI.

If Ajay scored 20 marks in DI then in that case Ajay's composite score = $2 \times 8 + 20 + 16 = 52$ which will be same as Geeta's composite score. Hence, we can say that in this case Ajay can't score 20 marks.

If Ajay scored 19 marks in DI then in that case Ajay's composite score = $2 \times 8 + 19 + 16 = 51$ which will be same as Danish's composite score. Hence, we can say that in this case Ajay can't score 19 marks.

Therefore, we can say that case 2 is not possible at all.

Candidate	Marks out of 20			Composite score
	DI	WE	GA	
Ajay	8	20	16	52
Bala		9	11	
Chetna	19	4	12	54
Danish	8	15	20	51
Ester	12	18	16	58
Falak	15	7	10	47
Geeta	14	19	6	53
Harini	5		20	
Indu	16	8	20	60
Jatin	20	16	14	70

It is given that all the candidates scored different marks in WE.

We can see that Ajay, Geeta and Ester has already scored 20, 19 and 18 marks in WE. Therefore, Harini can score a maximum of 17 marks in WE. If Harini's score in WE is 17, then Harini's composite score = $2 \cdot 5 + 17 + 20 = 47$ which is same as Falak's composite score. Hence, we can say that Harini can't score 17 marks in WE. Jatin and Danish have already scored 16 and 15 marks respectively.

Therefore, we can say that the maximum marks that Harini could have scored in WE = 14.

Quantitative Aptitude

67. If x is a positive quantity such that $2^x = 3^{\log_5 2}$, then x is equal to

- A $\log_5 8$
- B $1 + \log_3 \left(\frac{5}{3}\right)$
- C $\log_5 9$
- D $1 + \log_5 \left(\frac{3}{5}\right)$

Answer: D

Explanation:

Given that: $2^x = 3^{\log_5 2}$

$$\Rightarrow 2^x = 2^{\log_5 3}$$

$$\Rightarrow x = \log_5 3$$

$$\Rightarrow x = \log_5 \frac{3 \cdot 5}{5}$$

$$\Rightarrow x = \log_5 3 + \log_5 5$$

$$\Rightarrow x = 1 + \log_5 3. \text{ Hence, option D is the correct answer.}$$

68. In a circle, two parallel chords on the same side of a diameter have lengths 4 cm and 6 cm. If the distance between these chords is 1 cm, then the radius of the circle, in cm, is

- A $\sqrt{13}$
- B $\sqrt{14}$
- C $\sqrt{11}$
- D $\sqrt{12}$

Answer: A

Explanation:

Given that two parallel chords on the same side of a diameter have lengths 4 cm and 6 cm.

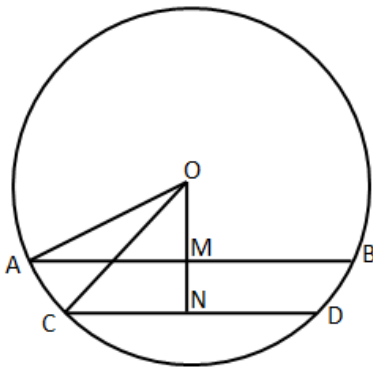

In the diagram we can see that $AB = 6$ cm, $CD = 4$ cm and $MN = 1$ cm.

We can see that M and N are the mid points of AB and CD respectively.

$AM = 3$ cm and $CN = 2$ cm. Let 'OM' be x cm.

In right angle triangle AMO,

$$AO^2 = AM^2 + OM^2$$

$$\Rightarrow AO^2 = 3^2 + x^2 \dots (1)$$

In right angle triangle CNO,

$$CO^2 = CN^2 + ON^2$$

$$\Rightarrow CO^2 = 2^2 + (OM + MN)^2$$

$$\Rightarrow CO^2 = 2^2 + (x + 1)^2 \dots (2)$$

We know that both AO and CO are the radius of the circle. Hence $AO = CO$

Therefore, we can equate equation (1) and (2)

$$3^2 + x^2 = 2^2 + (x + 1)^2$$

$$\Rightarrow x = 2 \text{ cm}$$

Therefore, the radius of the circle

$$AO = \sqrt{AM^2 + OM^2}$$

$$\Rightarrow AO = \sqrt{3^2 + 2^2} = \sqrt{13}. \text{ Hence, option A is the correct answer.}$$

69. Humans and robots can both perform a job but at different efficiencies. Fifteen humans and five robots working together take thirty days to finish the job, whereas five humans and fifteen robots working together take sixty days to finish it. How many days will fifteen humans working together (without any robot) take to finish it?

- A 45
- B 36

C 32

D 40

Answer: C

Explanation:

Let the efficiency of humans be 'h' and the efficiency of robots be 'r'.

In the first case,

$$\text{Total work} = (15h + 5r) * 30 \dots (i)$$

In the second case,

$$\text{Total work} = (5h + 15r) * 60 \dots (ii)$$

On equating (i) and (ii), we get

$$(15h + 5r) * 30 = (5h + 15r) * 60$$

$$\text{Or, } 15h + 5r = 10h + 30r$$

$$\text{Or, } 5h = 25r$$

$$\text{Or, } h = 5r$$

$$\text{Total work} = (15h + 5r) * 30 = (15h + h) * 30 = 480h$$

$$\text{Time taken by 15 humans} = \frac{480h}{15h} \text{ days} = 32 \text{ days.}$$

Hence, option C is the correct answer.

70. Let ABCD be a rectangle inscribed in a circle of radius 13 cm. Which one of the following pairs can represent, in cm, the possible length and breadth of ABCD?

A 24, 10

B 25, 9

C 25, 10

D 24, 12

Answer: A

Explanation:

Let ABCD be a rectangle inscribed in a circle of radius 13 cm. Which one of the following pairs can represent, in cm, the possible length and breadth of ABCD?

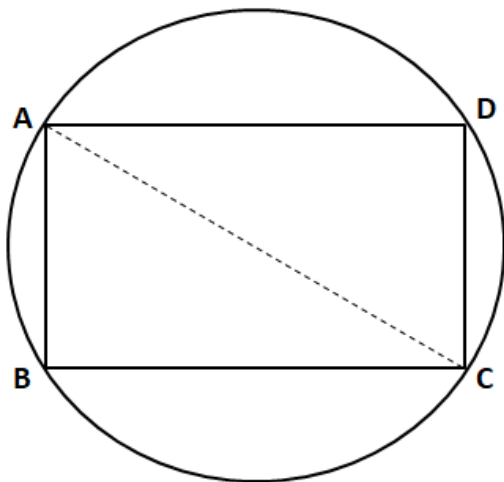

We know that AC is the diameter and $\angle ABC = 90^\circ$. $AC = 2 * 13 = 26$ cm

In right angle triangle ABC,

$$AC^2 = AB^2 + BC^2$$

$$\Rightarrow AB^2 + BC^2 = 26^2$$

$$\Rightarrow AB^2 + BC^2 = 676$$

Let us check with the options.

Option (A): $24^2 + 10^2 = 676$. Hence, this is a possible answer.

Option (B): $25^2 + 9^2 = 706 \neq 676$. Hence, this is an incorrect pair.

Option (C): $25^2 + 10^2 = 725 \neq 676$. Hence, this is an incorrect pair.

Option (D): $24^2 + 12^2 = 720 \neq 676$. Hence, this is an incorrect pair.

Therefore, we can say that option A is the correct answer.

71. Points E, F, G, H lie on the sides AB, BC, CD, and DA, respectively, of a square ABCD. If EFGH is also a square whose area is 62.5% of that of ABCD and CG is longer than EB, then the ratio of length of EB to that of CG is

A 3 : 8

B 2 : 5

C 4 : 9

D 1 : 3

Answer: D

Explanation:

It is given that EFGH is also a square whose area is 62.5% of that of ABCD. Let us assume that E divides AB in $x : 1$. Because of symmetry we can see that points F, G and H divide BC, CD and DA in $x : 1$.

Let us assume that ' $x+1$ ' is the length of side of square ABCD.

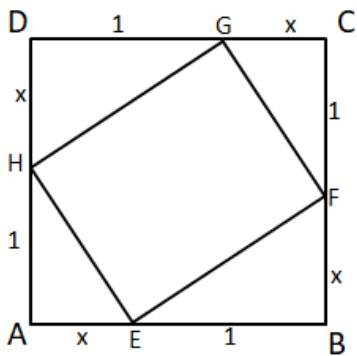

Area of square ABCD = $(x + 1)^2$ sq. units.

$$\text{Therefore, area of square EFGH} = \frac{62.5}{100} * (x + 1)^2 = \frac{5(x + 1)^2}{8} \dots (1)$$

In right angle triangle EBF,

$$EF^2 = EB^2 + BF^2$$

$$\Rightarrow EF = \sqrt{1^2 + x^2}$$

Therefore, the area of square EFGH = $EF^2 = x^2 + 1 \dots (2)$

By equating (1) and (2),

$$x^2 + 1 = \frac{5(x+1)^2}{8}$$

$$\Rightarrow 8x^2 + 8 = 5x^2 + 10x + 5$$

$$\Rightarrow 3x^2 - 10x + 3 = 0$$

$$\Rightarrow (x-3)(3x-1) = 0$$

$$\Rightarrow x = 3 \text{ or } 1/3$$

The ratio of length of EB to that of CG = 1 : x

EB : CG = 1 : 3 or 3 : 1. Hence, option D is the correct answer.

72. Point P lies between points A and B such that the length of BP is thrice that of AP. Car 1 starts from A and moves towards B. Simultaneously, car 2 starts from B and moves towards A. Car 2 reaches P one hour after car 1 reaches P. If the speed of car 2 is half that of car 1, then the time, in minutes, taken by car 1 in reaching P from A is

Answer:12

Explanation:

Let the distance between A and B be 4x.

Length of BP is thrice the length of AP.

=> AP = x and BP = 3x

Let the speed of car 1 be s and the speed of car 2 be 0.5s.

Car 2 reaches P one hour (60 minutes) after Car 1 reaches P.

$$\Rightarrow x/s + 60 = 3x/0.5s$$

$$x/s + 60 = 6x/s$$

$$5x/s = 60$$

$$x/s = 12$$

Time taken by car 1 in reaching P from A = x/s = 12 minutes.

Therefore, 12 is the correct answer.

73. Let $f(x) = \min(2x^2, 52 - 5x)$ where x is any positive real number. Then the maximum possible value of f(x) is

Answer:32

Explanation:

$$f(x) = \min(2x^2, 52 - 5x)$$

The maximum possible value of this function will be attained at the point in which $2x^2$ is equal to $52 - 5x$.

$$2x^2 = 52 - 5x$$

$$2x^2 + 5x - 52 = 0$$

$$(2x + 13)(x - 4) = 0$$

$$\Rightarrow x = \frac{-13}{2} \text{ or } x = 4$$

It has been given that x is a positive real number. Therefore, we can eliminate the case $x = \frac{-13}{2}$.

$x = 4$ is the point at which the function attains the maximum value. 4 is not the maximum value of the function.

Substituting $x = 4$ in the original function, we get, $2x^2 = 2 * 4^2 = 32$.

$$f(x) = 32.$$

Therefore, 32 is the right answer.

74. While multiplying three real numbers, Ashok took one of the numbers as 73 instead of 37. As a result, the product went up by 720. Then the minimum possible value of the sum of squares of the other two numbers is

Answer:40

Explanation:

We know that one of the 3 numbers is 37.
Let the product of the other 2 numbers be x.
It has been given that $73x - 37x = 720$
 $36x = 720$
 $x = 20$

Product of 2 real numbers is 20.
We have to find the minimum possible value of the sum of the squares of the 2 numbers.
Let $x = a * b$
It has been given that $a * b = 20$

The least possible sum for a given product is obtained when the numbers are as close to each other as possible.
Therefore, when $a = b$, the value of a and b will be $\sqrt{20}$.

Sum of the squares of the 2 numbers = $20 + 20 = 40$.

Therefore, 40 is the correct answer.

75. Train T leaves station X for station Y at 3 pm. Train S, traveling at three quarters of the speed of T, leaves Y for X at 4 pm. The two trains pass each other at a station Z, where the distance between X and Z is three-fifths of that between X and Y. How many hours does train T take for its journey from X to Y?

Answer:15

Explanation:

Train T starts at 3 PM and train S starts at 4 PM.
Let the speed of train T be t.
=> Speed of train S = $0.75t$.

When the trains meet, train t would have traveled for one more hour than train S.
Let us assume that the 2 trains meet x hours after 3 PM. Trains S would have traveled for x-1 hours.

Distance traveled by train T = xt
Distance traveled by train S = $(x-1) * 0.75t = 0.75xt - 0.75t$

We know that train T has traveled three fifths of the distance. Therefore, train S should have traveled two-fifths the distance between the 2 cities.

$\Rightarrow (xt) / (0.75xt - 0.75t) = 3/2$
 $2xt = 2.25xt - 2.25t$
 $0.25x = 2.25$
 $x = 9$ hours.

Train T takes 9 hours to cover three-fifths the distance. Therefore, to cover the entire distance, train T will take $9 * (5/3) = 15$ hours.
Therefore, 15 is the correct answer.

76. Two types of tea, A and B, are mixed and then sold at Rs. 40 per kg. The profit is 10% if A and B are mixed in the ratio 3 : 2, and 5% if this ratio is 2 : 3. The cost prices, per kg, of A and B are in the ratio

A 17 : 25

B 18 : 25

C 19 : 24

D 21 : 25

Answer: C

Explanation:

The selling price of the mixture is Rs.40/kg.

Let a be the price of 1 kg of tea A in the mixture and b be the price per kg of tea B.

It has been given that the profit is 10% if the 2 varieties are mixed in the ratio 3:2

Let the cost price of the mixture be x.

It has been given that $1.1x = 40$

$$x = 40/1.1$$

Price per kg of the mixture in ratio 3:2 = $\frac{3a+2b}{5}$

$$\frac{3a+2b}{5} = 1.1$$

$$3.3a + 2.2b = 200 \text{ -----(1)}$$

The profit is 5% if the 2 varieties are mixed in the ratio 2:3.

Price per kg of the mixture in ratio 2:3 = $\frac{2a+3b}{5}$

$$\frac{2a+3b}{5} = 1.05$$

$$2.1a + 3.15b = 200 \text{ -----(2)}$$

Equating (1) and (2), we get,

$$3.3a + 2.2b = 2.1a + 3.15b$$

$$1.2a = 0.95b$$

$$\frac{a}{b} = \frac{0.95}{1.2}$$

$$\frac{a}{b} = \frac{19}{24}$$

Therefore, option C is the right answer.

77. Given an equilateral triangle T1 with side 24 cm, a second triangle T2 is formed by joining the midpoints of the sides of T1. Then a third triangle T3 is formed by joining the midpoints of the sides of T2. If this process of forming triangles is continued, the sum of the areas, in sq cm, of infinitely many such triangles T1, T2, T3,... will be

A $188\sqrt{3}$

B $248\sqrt{3}$

C $164\sqrt{3}$

D $192\sqrt{3}$

Answer: D

Explanation:

We can see that T_2 is formed by using the mid points of T_1 . Hence, we can say that area of triangle of T_2 will be $(1/4)$ th of the area of triangle T_1 .

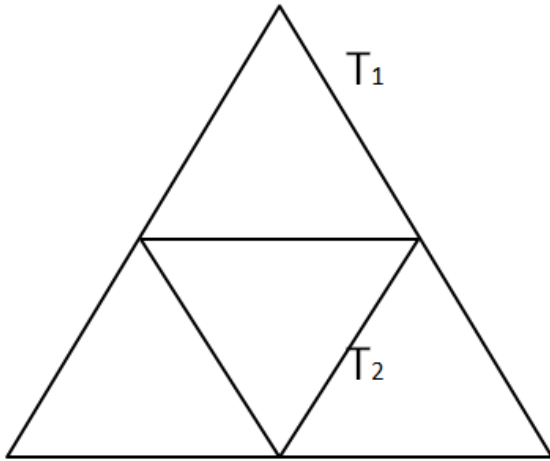

$$\text{Area of triangle } T_1 = \frac{\sqrt{3}}{4} * (24)^2 = 144\sqrt{3} \text{ sq. cm}$$

$$\text{Area of triangle } T_2 = \frac{144\sqrt{3}}{4} = 36\sqrt{3} \text{ sq. cm}$$

Sum of the area of all triangles = $T_1 + T_2 + T_3 + \dots$

$$\Rightarrow T_1 + T_1/4 + T_1/4^2 + \dots$$

$$\Rightarrow 1 - 0.25$$

$$\Rightarrow 3 * T_1$$

$$\Rightarrow 3 * 144\sqrt{3}$$

$$\Rightarrow 192\sqrt{3}$$

Hence, option D is the correct answer.

78. If $\log_{12} 81 = p$, then $3^{(4+p)}$ is equal to

- A $\log_4 16$
- B $\log_6 16$
- C $\log_2 8$
- D $\log_6 8$

Answer: D

Explanation:

Given that: $\log_{12} 81 = p$

$$\Rightarrow \log_{81} 12 = p$$

$$\Rightarrow \log_3 3 * 4 = p$$

$$\Rightarrow 1 + \log_3 4 = p$$

Using Componendo and Dividendo,

$$\Rightarrow \frac{1 + \log_3 4 - 1}{1 + \log_3 4 + 1} = \frac{4 - p}{4 + p}$$

$$\Rightarrow \frac{\log_3 4}{2 + \log_3 4} = \frac{4 - p}{4 + p}$$

$$\Rightarrow \frac{\log_3 4}{\log_3 9 + \log_3 4} = \frac{4 - p}{4 + p}$$

$$\Rightarrow \frac{\log_3 4}{\log_3 36} = \frac{4 - p}{4 + p}$$

$$\Rightarrow 3 * \frac{4 - p}{4 + p} = \log_3 36$$

$$\Rightarrow 3 * \frac{4 - p}{4 + p} = \log_3 64$$

$$\Rightarrow 3 * \frac{4 - p}{4 + p} = \log_{36} 64$$

$$\Rightarrow 3 * \frac{4 - p}{4 + p} = \log_{6^2} 8^2 = \log_6 8. \text{ Hence, option D is the correct answer.}$$

79. John borrowed Rs. 2,10,000 from a bank at an interest rate of 10% per annum, compounded annually. The loan was repaid in two equal instalments, the first after one year and the second after another year. The first instalment was interest of one year plus part of the principal amount, while the second was the rest of the principal amount plus due interest thereon. Then each instalment, in Rs., is

Answer:121000

Explanation:

We have to equate the installments and the amount due either at the time of borrowing or at the time when the entire loan is repaid. Let us bring all values to the time frame in which all the dues get settled, i.e, by the end of 2 years.

John borrowed Rs. 2,10,000 from the bank at 10% per annum. This loan will amount to $2,10,000 * 1.1 * 1.1 = \text{Rs.} 2,54,100$ by the end of 2 years.

Let the amount paid as installment every year be Rs.x.

John would pay the first installment by the end of the first year. Therefore, we have to calculate the interest on this amount from the end of the first year to the end of the second year. The loan will get settled the moment the second installment is paid.

$$\Rightarrow 1.1x + x = 2,54,100$$

$$2.1x = 2,54,100$$

$$\Rightarrow x = \text{Rs. } 1,21,000.$$

Therefore, 121000 is the correct answer.

80. When they work alone, B needs 25% more time to finish a job than A does. They two finish the job in 13 days in the following manner: A works alone till half the job is done, then A and B work together for four days, and finally B works alone to complete the remaining 5% of the job. In how many days can B alone finish the entire job?

- A 20
- B 22
- C 16
- D 18

Answer: A

Explanation:

Let us assume that A can complete 'a' units of work in a day and B can complete 'b' units of work in a day.

A works alone till half the work is completed.

A and B work together for 4 days and B works alone to complete the last 5% of the work.

=> A and B in 4 days can complete 45% of the work.

Let us assume the total amount of work to be done to be 100 units.

$$4a + 4b = 45 \text{ -----(1)}$$

B needs 25% more time than A to finish a job.

$$\Rightarrow 1.25*b = a \text{ -----(2)}$$

Substituting (2) in (1), we get,

$$5b + 4b = 45$$

$$9b = 45$$

$$b = 5 \text{ units/day}$$

B alone can finish the job in $100/5 = 20$ days.

Therefore, option A is the right answer.

81. How many numbers with two or more digits can be formed with the digits 1,2,3,4,5,6,7,8,9, so that in every such number, each digit is used at most once and the digits appear in the ascending order?

Answer:502

Explanation:

It has been given that the digits in the number should appear in the ascending order. Therefore, there is only 1 possible arrangement of the digits once they are selected to form a number.

There are 9 numbers (1,2,3,4,5,6,7,8,9) in total.

2 digit numbers can be formed in 9C_2 ways.

3 digit numbers can be formed in 9C_3 ways.

.....

..9 digit number can be formed in 9C_9 ways.

$$\text{We know that } {}^nC_0 + {}^nC_1 + {}^nC_2 + \dots + {}^nC_n = 2^n$$

$$\Rightarrow {}^9C_0 + {}^9C_1 + {}^9C_2 + \dots + {}^9C_9 = 2^9$$

$${}^9C_0 + {}^9C_1 + \dots + {}^9C_9 = 512$$

We have to subtract 9C_0 and 9C_1 from both the sides of the equations since we cannot form single digit numbers.

$$\Rightarrow 9C_2 + 9C_3 + \dots + 9C_9 = 512 - 1 - 9$$

$$9C_2 + 9C_3 + \dots + 9C_9 = 502$$

Therefore, 502 is the right answer.

82. A right circular cone, of height 12 ft, stands on its base which has diameter 8 ft. The tip of the cone is cut off with a plane which is parallel to the base and 9 ft from the base. With $\pi = 22/7$, the volume, in cubic ft, of the remaining part of the cone is

Answer:198

Explanation:

We are given that diameter of base = 8 ft. Therefore, the radius of circular base = $8/2 = 4$ ft

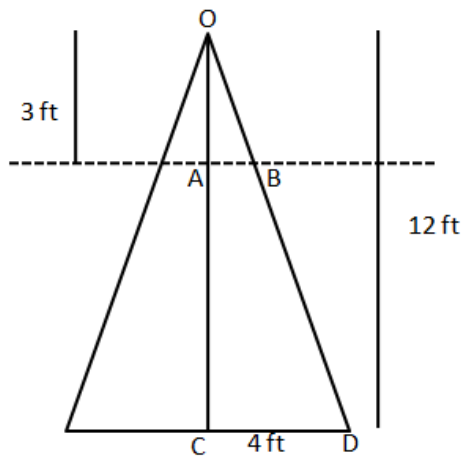

In triangle OAB and OCD

$$\frac{OA}{AB} = \frac{OC}{CD}$$

$$\Rightarrow AB = \frac{3 * 4}{12} = 1 \text{ ft.}$$

Therefore, the volume of remaining part = Volume of entire cone - Volume of smaller cone

$$\Rightarrow 3 * \pi * 4^2 * 12 - 3 * \pi * 1^2 * 3$$

$$\Rightarrow 3 * \pi * 189$$

$$\Rightarrow 7 * 3 * 189$$

$$\Rightarrow 198 \text{ cubic ft}$$

83. Raju and Lalitha originally had marbles in the ratio 4:9. Then Lalitha gave some of her marbles to Raju. As a result, the ratio of the number of marbles with Raju to that with Lalitha became 5:6. What fraction of her original number of marbles was given by Lalitha to Raju?

A $\frac{1}{5}$

B $\frac{6}{19}$

C $\frac{1}{4}$

D $\frac{7}{33}$

Answer: D

Explanation:

Let the number of marbles with Raju and Lalitha initially be $4x$ and $9x$.
Let the number of marbles that Lalitha gave to Raju be a .

It has been given that $(4x+a)/(9x-a) = 5/6$

$$24x + 6a = 45x - 5a$$

$$11a = 21x$$

$$a/x = 21/11$$

Fraction of original marbles given to Raju by Lalitha = $a/9x$ (Since Lalitha had $9x$ marbles initially).

$$a/9x = 21/99$$

$$= 7/33.$$

Therefore, option D is the right answer.

84. Each of 74 students in a class studies at least one of the three subjects H, E and P. Ten students study all three subjects, while twenty study H and E, but not P. Every student who studies P also studies H or E or both. If the number of students studying H equals that studying E, then the number of students studying H is

Answer:52

Explanation:

Let us draw a Venn diagram using the information present in the question.

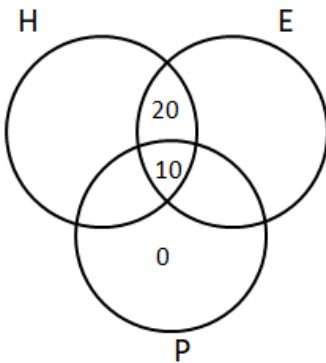

It is given that the number of students studying H equals that studying E.

Let 'x' be the total number of students who studied H, and H and P but not E. We can also say that the same will be the number of students who studied E, and E and P but not H. Therefore,

$$x + 20 + 10 + x = 74$$

$$x = 22$$

Hence, the number of students studying H = $22 + 10 + 20 = 52$

85. A wholesaler bought walnuts and peanuts, the price of walnut per kg being thrice that of peanut per kg. He then sold 8 kg of peanuts at a profit of 10% and 16 kg of walnuts at a profit of 20% to a shopkeeper. However, the shopkeeper lost 5 kg of walnuts and 3 kg of peanuts in transit. He then mixed the remaining nuts and sold the mixture at Rs. 166 per kg, thus making an overall profit of 25%. At what price, in Rs. per kg, did the wholesaler buy the walnuts?

- A 96
- B 98
- C 86
- D 84

Answer: A

Explanation:

Let the price of peanuts be Rs. $100x$ per kg

Then, the price of walnuts = Rs. $300x$ per kg

Cost price of peanuts for the shopkeeper = Rs. $110x$ per kg

Cost price of walnuts for the shopkeeper = Rs. $360x$ per kg

Total cost incurred to the shopkeeper while buying = Rs. $(8 * 110x + 16 * 360x) = Rs. 6640x$

Since, 5kg walnut and 3kg peanuts are lost in transit, the shopkeeper will be remained with $(16-5)+(8-3)=16$ kgs of nuts

Total selling price that the shopkeeper got = Rs. $(166 * 16) = Rs. 2656$

Profit = 25%

So, cost price = Rs. 2124.80

Therefore, $6640x = 2124.80$

On solving, we get $x = 0.32$

Therefore, price of walnuts = Rs. $(300 * 0.32) = Rs. 96$ per kg.

Hence, option A is the correct answer

86. If among 200 students, 105 like pizza and 134 like burger, then the number of students who like only burger can possibly be

- A 23
- B 26
- C 96
- D 93

Answer: D

Explanation:

It has been given that among 200 students, 105 like pizza and 134 like burger.

The question asks us to find out the number of students who can be liking only burgers among the given values.

The least number of students who like only burger will be obtained when everyone who likes pizza likes burger too.

In this case, 105 students will like pizza and burger and $134-105 = 29$ students will like only burger. Therefore, the number of students who like only burger cannot be less than 29.

The maximum number of students who like only burger will be obtained when we try to separate the 2 sets as much as possible.

There are 200 students in total. 105 of them like pizza. Therefore, the remaining 95 students can like only burger and $134-95 = 39$ students can like both pizza and burger. As we can see, the number of students who like burger cannot exceed 95.

The number of students who like only burger should lie between 29 and 95 (both the values are included).

93 is the only value among the given options that satisfies this condition and hence, option D is the right answer.

87. If $f(x + 2) = f(x) + f(x + 1)$ for all positive integers x , and $f(11) = 91$, $f(15) = 617$, then $f(10)$ equals

Answer:54

Explanation:

$$f(x + 2) = f(x) + f(x + 1)$$

As we can see, the value of a term is the sum of the 2 terms preceding it.

It has been given that $f(11) = 91$ and $f(15) = 617$.

We have to find the value of $f(10)$.

$$\text{Let } f(10) = b$$

$$f(12) = b + 91$$

$$f(13) = 91 + b + 91 = 182 + b$$

$$f(14) = 182 + b + 91 + b = 273 + 2b$$

$$f(15) = 273 + 2b + 182 + b = 455 + 3b$$

It has been given that $455 + 3b = 617$

$$3b = 162$$

$$\Rightarrow b = 54$$

Therefore, 54 is the correct answer.

88. In an apartment complex, the number of people aged 51 years and above is 30 and there are at most 39 people whose ages are below 51 years. The average age of all the people in the apartment complex is 38 years. What is the largest possible average age, in years, of the people whose ages are below 51 years?

A 27

B 25

C 26

D 28

Answer: D

Explanation:

The possible average age of people whose ages are below 51 years will be maximum if the average age of the number of people aged 51 years and above is minimum. Hence, we can say that there are 30 people having same age 51 years.

Let 'x' be the maximum average age of people whose ages are below 51.

Then we can say that,

$$51 * 30 + 39 * x$$

$$30 + 39 = 38$$

$$\Rightarrow 1530 + 39x = 2622$$

$$\Rightarrow x = 1092/39 = 28$$

Hence, we can say that option D is the correct answer.

89. A trader sells 10 litres of a mixture of paints A and B, where the amount of B in the mixture does not exceed that of A. The cost of paint A per litre is Rs. 8 more than that of paint B. If the trader sells the entire mixture for Rs. 264 and makes a profit of 10%, then the highest possible cost of paint B, in Rs. per litre, is

- A 16
- B 26
- C 20
- D 22

Answer: C

Explanation:

Let the price of paint B be x .
Price of paint A = $x+8$

We know that the amount of paint B in the mixture does not exceed the amount of paint A. Therefore, paint B can at the maximum compose 50% of the mixture.

The seller sells 10 litres of paint at Rs.264 earning a profit of 10%.
=> The cost price of 10 litres of the paint mixture = Rs. 240

Therefore, the cost of 1 litre of the mixture = Rs.24

We have to find the highest possible cost of paint B.

When we increase the cost of paint B, the cost of paint A will increase too. If the cost price of the mixture is closer to the cost of paint B, then the amount of paint B present in the mixture should be greater than the amount of paint A present in the mixture. The highest possible cost of paint B will be obtained when the volumes of paint A and paint B in the mixture are equal.

$$\begin{aligned} \Rightarrow (x+x+8)/2 &= 24 \\ 2x &= 40 \\ x &= \text{Rs. } 20 \end{aligned}$$

Therefore, option C is the right answer.

90. In a parallelogram ABCD of area 72 sq cm, the sides CD and AD have lengths 9 cm and 16 cm, respectively. Let P be a point on CD such that AP is perpendicular to CD. Then the area, in sq cm, of triangle APD is

- A $32\sqrt{3}$
- B $18\sqrt{3}$
- C $24\sqrt{3}$
- D $12\sqrt{3}$

Answer: A

Explanation:

In a parallelogram ABCD of area 72 sq cm, the sides CD and AD have lengths 9 cm and 16 cm, respectively. Let P be a point on CD such that AP is perpendicular to CD. Then the area, in sq cm, of triangle APD is

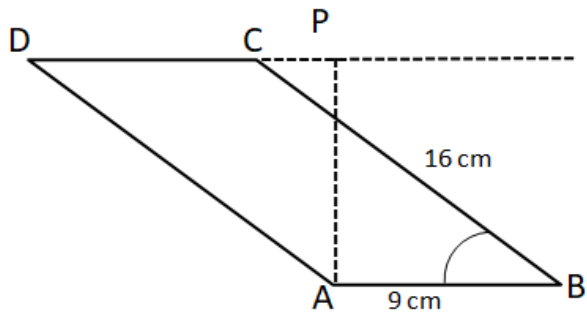

Given that area of parallelogram = 72 sq cm

1

Area of triangle ABC = $\frac{1}{2}$ * area of parallelogram

1

$(\frac{1}{2}) * AB * BC * \sin ABC = \frac{1}{2} * 72$

1

$\sin ABC = \frac{1}{2}$

$\angle ABC = 30^\circ$

Let us draw a perpendicular CQ from C to AB.

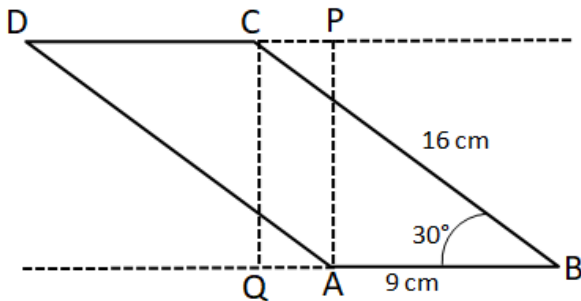

$\angle B = \angle D = 30^\circ$ (opposite angles in a parallelogram)

$\angle QCB = \angle DAP = 60^\circ$ (Sum of angles in a triangle = 180)

In triangles APD and CQB, $AP = CQ$, $AD = CB$ (opposite sides of a parallelogram), $\angle QCB = \angle DAP = 60^\circ$

Hence APD and CQB are congruent triangles using SAS property.

Therefore, we can say that area of triangle APD = area of triangle CQB

In right angle triangle CQB,

$\sqrt{3}$

$QB = CB \cos 30^\circ = 16 * \frac{\sqrt{3}}{2} = 8\sqrt{3}$ cm

1

$CQ = CB \sin 30^\circ = 16 * \frac{1}{2} = 8$ cm

Therefore, area of triangle CQB = $\frac{1}{2} * CQ * QB = \frac{1}{2} * 8 * 8\sqrt{3} = 32\sqrt{3}$

Hence, we can say that area of triangle APD = $32\sqrt{3}$.

91. If $U^2 + (U - 2V - 1)^2 = -4V(U + V)$, then what is the value of $U + 3V$?

A 0

B 1
2

C -1
4

1
D 4

Answer: C

Explanation:

$$\text{Given that } U^2 + (U - 2V - 1)^2 = -4V(U + V)$$

$$\Rightarrow U^2 + (U - 2V - 1)(U - 2V - 1) = -4V(U + V)$$

$$\Rightarrow U^2 + (U^2 - 2UV - U - 2UV + 4V^2 + 2V - U + 2V + 1) = -4V(U + V)$$

$$\Rightarrow U^2 + (U^2 - 4UV - 2U + 4V^2 + 4V + 1) = -4V(U + V)$$

$$\Rightarrow 2U^2 - 4UV - 2U + 4V^2 + 4V + 1 = -4UV - 4V^2$$

$$\Rightarrow 2U^2 - 2U + 8V^2 + 4V + 1 = 0$$

$$\Rightarrow 2[U^2 - U + 4] + 8[V^2 + 2 + 16] = 0$$

$$\Rightarrow 2(U - 2)^2 + 8(V + 4)^2 = 0$$

Sum of two square terms is zero i.e. individual square term is equal to zero.

$$U - 2 = 0 \text{ and } V + 4 = 0$$

$$U = 2 \text{ and } V = -4$$

$$\text{Therefore, } U + 3V = 2 + (-1) * 3 = -1$$

92. In a circle with center O and radius 1 cm, an arc AB makes an angle 60 degrees at O. Let R be the region bounded by the radii OA, OB and the arc AB. If C and D are two points on OA and OB, respectively, such that OC = OD and the area of triangle OCD is half that of R, then the length of OC, in cm, is

- A $(\frac{\pi}{4\sqrt{3}})^{\frac{1}{2}}$
- B $(\frac{\pi}{6})^{\frac{1}{2}}$
- C $(\frac{\pi}{3\sqrt{3}})^{\frac{1}{2}}$
- D $(\frac{\pi}{4})^{\frac{1}{2}}$

Answer: C

Explanation:

It is given that radius of the circle = 1 cm

Chord AB subtends an angle of 60° on the centre of the given circle. R be the region bounded by the radii OA, OB and the arc AB.

$$\text{Therefore, } R = \frac{60^\circ}{360^\circ} * \text{Area of the circle} = \frac{60}{360} * \pi * (1)^2 = \frac{\pi}{6} \text{ sq. cm}$$

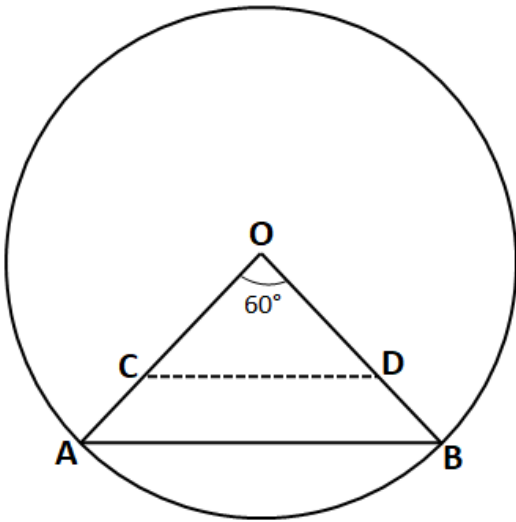

It is given that $OC = OD$ and area of triangle OCD is half that of R . Let $OC = OD = x$.

$$\text{Area of triangle } COD = \frac{1}{2} * OC * OD * \sin 60^\circ$$

$$6 * \frac{\pi}{2} = \frac{1}{2} * x * x * \frac{\sqrt{3}}{2}$$

$$\Rightarrow x^2 = 3\sqrt{3}$$

$$\Rightarrow x = (3\sqrt{3})^{\frac{1}{2}} \text{ cm. Hence, option C is the correct answer.}$$

93. The distance from A to B is 60 km. Partha and Narayan start from A at the same time and move towards B. Partha takes four hours more than Narayan to reach B. Moreover, Partha reaches the mid-point of A and B two hours before Narayan reaches B. The speed of Partha, in km per hour, is

- A 6
- B 4
- C 3
- D 5

Answer: D

Explanation:

Let the time taken by Partha to cover 60 km be x hours.

Narayan will cover 60 km in $x-4$ hours.

$$\text{Speed of Partha} = \frac{60}{x}$$

$$\text{Speed of Narayan} = \frac{60}{x-4}$$

Partha reaches the mid-point of A and B two hours before Narayan reaches B.

$$\Rightarrow \frac{30}{x} + 2 = \frac{60}{x-4}$$

$$\frac{x}{2} + 2 = x - 4$$

$$\frac{x+4}{2} = x - 4$$

$$x + 4 = 2x - 8$$

$$x = 12$$

Partha will take 12 hours to cross 60 km.

$$\Rightarrow \text{Speed of Partha} = \frac{60}{12} = 5 \text{ Kmph.}$$

Therefore, option D is the right answer.

94. Let x, y, z be three positive real numbers in a geometric progression such that $x < y < z$. If $5x, 16y,$ and $12z$ are in an arithmetic progression then the common ratio of the geometric progression is

A $\frac{3}{6}$

B $\frac{1}{6}$

C $\frac{5}{2}$

D $\frac{3}{2}$

Answer: C

Explanation:

$$\text{Let } x = a, y = ar \text{ and } z = ar^2$$

It is given that, $5x, 16y$ and $12z$ are in AP.

$$\text{so, } 5x + 12z = 32y$$

On replacing the values of x, y and z , we get

$$5a + 12ar^2 = 32ar$$

$$\text{or, } 12r^2 - 32r + 5 = 0$$

$$\text{On solving, } r = \frac{5}{2} \text{ or } \frac{1}{6}$$

For $r = \frac{1}{6}$, $x < y < z$ is not satisfied.

$$\text{So, } r = \frac{5}{2}$$

Hence, option C is the correct answer.

95. Given that $x^{2018}y^{2017} = \frac{1}{2}$, and $x^{2016}y^{2019} = 8$, then value of $x^2 + y^3$ is

A $\frac{31}{4}$

B $\frac{35}{4}$

C $\frac{37}{4}$

D $\frac{33}{4}$

Answer: D

Explanation:

$$\text{Given that } x^{2018}y^{2017} = \frac{1}{2} \dots (1)$$

$$x^{2016}y^{2019} = 8 \dots (2)$$

Equation (2)/ Equation (1)

$$\frac{y^2}{x^2} = \frac{8}{1/2}$$

$$x = 4 \text{ or } -4$$

Case 1: When $x = 4$

$$x^{2018}(4x)^{2017} = 2$$

$$x^{2018+2017}(2)^{4034} = 2$$

$$x^{4035} = (2)^{4035}$$

$$x = 2$$

$$\text{Since, } x = 4, \Rightarrow y = 2$$

$$\text{Therefore, } x^2 + y^3 = 4 + 8 = 12$$

Case 2: When $x = -4$

$$x^{2018}(-4x)^{2017} = 2$$

$$x^{2018+2017}(2)^{4034} = 2$$

$$x^{4035} = (-2)^{4035}$$

$$x = -2$$

$$\text{Since, } x = -4, \Rightarrow y = 2$$

$$\text{Therefore, } x^2 + y^3 = 4 + 8 = 12. \text{ Hence, option D is the correct answer.}$$

96. A tank is fitted with pipes, some filling it and the rest draining it. All filling pipes fill at the same rate, and all draining pipes drain at the same rate. The empty tank gets completely filled in 6 hours when 6 filling and 5 draining pipes are on, but this time becomes 60 hours when 5 filling and 6 draining pipes are on. In how many hours will the empty tank get completely filled when one draining and two filling pipes are on?

Answer:10

Explanation:

Let the efficiency of filling pipes be 'x' and the efficiency of draining pipes be 'y'.

In the first case,

$$\text{Capacity of tank} = (6x - 5y) * 6 \dots\dots\dots(i)$$

In the second case,

$$\text{Capacity of tank} = (5x - 6y) * 60 \dots\dots(ii)$$

On equating (i) and (ii), we get

$$(6x - 5y) * 6 = (5x - 6y) * 60$$

$$\text{or, } 6x - 5y = 50x - 60y$$

$$\text{or, } 44x = 55y$$

$$\text{or, } 4x = 5y$$

$$\text{or, } x = 1.25y$$

$$\text{Capacity of the tank} = (6x - 5y) * 6 = (7.5y - 5y) * 6 = 15y$$

$$\text{Net efficiency of 2 filling and 1 draining pipes} = (2x - y) = (2.5y - y) = 1.5y$$

$$\text{Time required} = \frac{15y}{1.5y} \text{ hours} = 10 \text{ hours.}$$

Hence, 10 is the correct answer.

97. If $\log_2(5 + \log_3 a) = 3$ and $\log_5(4a + 12 + \log_2 b) = 3$, then $a + b$ is equal to

- A 59
- B 40
- C 32
- D 67

Answer: A

Explanation:

$$\log_2(5 + \log_3 a) = 3$$

$$\Rightarrow 5 + \log_3 a = 8$$

$$\Rightarrow \log_3 a = 3$$

$$\text{or } a = 27$$

$$\log_5(4a + 12 + \log_2 b) = 3$$

$$\Rightarrow 4a + 12 + \log_2 b = 125$$

Putting $a = 27$, we get

$$\log_2 b = 5$$

$$\text{or, } b = 32$$

$$\text{So, } a + b = 27 + 32 = 59$$

Hence, option A is the correct answer.

98. A CAT aspirant appears for a certain number of tests. His average score increases by 1 if the first 10 tests are not considered, and decreases by 1 if the last 10 tests are not considered. If his average scores for the first 10 and the last 10 tests are 20 and 30, respectively, then the total number of tests taken by him is

Answer:60

Explanation:

Let the total number of tests be 'n' and the average by 'A'

$$\text{Total score} = n * A$$

When 1st 10 tests are excluded, decrease in total value of scores = $(nA - 20 * 10) = (nA - 200)$

Also, $(n - 10)(A + 1) = (nA - 200)$

On solving, we get $10A - n = 190$(i)

When last 10 tests are excluded, decrease in total value of scores = $(nA - 30 * 10) = (nA - 300)$

Also, $(n - 10)(A - 1) = (nA - 300)$

On solving, we get $10A + n = 310$(ii)

From (i) and (ii), we get $n = 60$

Hence, 60 is the correct answer.

99. The number of integers x such that $0.25 \leq 2^x \leq 200$ and $2^x + 2$ is perfectly divisible by either 3 or 4, is

Answer:5

Explanation:

At $x = 0$, $2^x = 1$ which is in the given range $[0.25, 200]$

$2^x + 2 = 1 + 2 = 3$ Which is divisible by 3. Hence, $x = 0$ is one possible solution.

At $x = 1$, $2^x = 2$ which is in the given range $[0.25, 200]$

$2^x + 2 = 2 + 2 = 4$ Which is divisible by 4. Hence, $x = 1$ is one possible solution.

At $x = 2$, $2^x = 4$ which is in the given range $[0.25, 200]$

$2^x + 2 = 4 + 2 = 6$ Which is divisible by 3. Hence, $x = 2$ is one possible solution.

At $x = 3$, $2^x = 8$ which is in the given range $[0.25, 200]$

$2^x + 2 = 8 + 2 = 10$ Which is not divisible by 3 or 4. Hence, $x = 3$ can't be a solution.

At $x = 4$, $2^x = 16$ which is in the given range $[0.25, 200]$

$2^x + 2 = 16 + 2 = 18$ Which is divisible by 3. Hence, $x = 4$ is one possible solution.

At $x = 5$, $2^x = 32$ which is in the given range $[0.25, 200]$

$2^x + 2 = 32 + 2 = 34$ Which is not divisible by 3 or 4. Hence, $x = 5$ can't be a solution.

At $x = 6$, $2^x = 64$ which is in the given range $[0.25, 200]$

$2^x + 2 = 64 + 2 = 66$ Which is divisible by 3. Hence, $x = 6$ is one possible solution.

At $x = 7$, $2^x = 128$ which is in the given range $[0.25, 200]$

$2^x + 2 = 128 + 2 = 130$ Which is not divisible by 3 or 4. Hence, $x = 7$ can't be a solution.

At $x = 8$, $2^x = 256$ which is not in the given range $[0.25, 200]$. Hence, x can't take any value greater than 7.

Therefore, all possible values of $x = \{0,1,2,4,6\}$. Hence, we can say that 'x' can take 5 different integer values.

100. In an examination, the maximum possible score is N while the pass mark is 45% of N . A candidate obtains 36 marks, but falls short of the pass mark by 68%. Which one of the following is then correct?

A $N \leq 200$.

B $243 \leq N \leq 252$.

C $201 \leq N \leq 242$.

D $N \geq 253$.

Answer: B

Explanation:

Total marks = N

Pass marks = 45% of N = $0.45N$

Marks obtained = 36

It is given that, obtained marks is 68% less than that pass marks

=>the obtained marks is 32% of the pass marks.

So, $0.32 * 0.45N = 36$

On solving, we get N = 250

Hence, option B is the correct answer.

