

A - SECTION - I
ODIA (COMPULSORY)

ପ୍ରଦତ୍ତ ଅନୁଛେଦଟି ପାଠକରି ପ୍ରଶ୍ନ (ନଂ 1 ରୁ 5 ପର୍ଯ୍ୟନ୍ତ)
ଗୁଡ଼ିକର ଉତ୍ତର ବାଛି :

ଅନେକ ପାଶ୍ଚାତ୍ୟ ସମାଲୋଚକ ଭାରତୀୟମାନଙ୍କର ରଚନା, ଗବେଷଣା ଓ ସାମାଜିକ ଆନ୍ଦୋଳନରେ ମୌଳିକତାର ଏକାନ୍ତ ଅଭାବ ଲକ୍ଷ୍ୟକରି ଆକ୍ଷେପ କରିଥାନ୍ତି । ଯେଉଁଠି ବ୍ୟକ୍ତି ଓ ସମାଜର ସକଳ ଦୈନନ୍ଦିନ କର୍ମ ଓ ଚିନ୍ତାଧାରାକୁ ପରମ୍ପରାହିଁ ନିୟନ୍ତ୍ରଣ କରେ, ସେଠି ମୌଳିକତାର ବିକାଶ ସହଜ ନୁହେଁ । ସେଠାରେ ଗତାନୁଗତିକତାହିଁ ସାଧାରଣ ଦୃଶ୍ୟ ହେବାର କଥା । ଭାରତବର୍ଷରେ ଅନେକାଂଶରେ ତାହାହିଁ ଘଟିଛି । ବିଶ୍ୱ ସଂସ୍କୃତିକୁ ଭାରତର ଧର୍ମ, ସାହିତ୍ୟ, କଳା ଓ ଦର୍ଶନ ଦେଇ ଅତୁଳନୀୟ ଦାନ ଥିଲେହେଁ, ମନୁଷ୍ୟର ପାର୍ଥବ ଜୀବନକୁ ସୁଖ ସ୍ୱାଚ୍ଛନ୍ଦ୍ୟମୟ କରିବା ପାଇଁ ଅନ୍ୟ ଜାତିମାନଙ୍କ ତୁଳନାରେ ଭାରତର ଦାନ ସାମାନ୍ୟ । ସକାଳୁ ଉଠି ରାତିରେ ଶୋଇବାକୁ ଗଲାଯାଏଁ ଆମର ଦୈନନ୍ଦିନ ଜୀବନ ସମ୍ପୂର୍ଣ୍ଣ ଭିନ୍ନଭିନ୍ନ ଦ୍ରବ୍ୟର ଆଲୋଚନା କଲେ ଏହା ସ୍ପଷ୍ଟ ହୋଇ ଉଠିବ । ସାନିଟାରୀ ଲାଟିନ, ଟାପଜଳ, ଦୈନିକ କାଗଜ, ମୁଦ୍ରାୟତ୍ତ, ଚା' ବା କଫି ଓ ଚାଇନା ଗିନା ଥାଲିଆ, ରିକ୍ସା ବା ମୋଟର, ରେଳଗାଡ଼ି, ଏରୋପ୍ଲେନ୍, ଇଲେକ୍ଟ୍ରିକ୍ ପଟ୍ଟା ଓ ଆଲୁଅ ପୁଣି ଡ୍ୱାଚ ଓ ଘଣ୍ଟା କହତ; ଏଥିରୁ କେଉଁଟି ଭାରତବର୍ଷର ନିଜସ୍ୱ ଉଦ୍ଭାବନ ? ଆମେ ଆମ ସଭ୍ୟତା ଓ ସଂସ୍କୃତି ନାମରେ ଲମ୍ପ-ଝମ୍ପ ଦେଇପାରୁ କିନ୍ତୁ ଯେଉଁ ସଂସ୍କୃତିର ଐତିହ୍ୟ ଆମର ବର୍ତ୍ତମାନକୁ ସୁନ୍ଦର ଓ ସ୍ୱଚ୍ଛନ୍ଦ କରିବାକୁ ଶିଖାଏନା ବା ସାହାଯ୍ୟ କରେନା କେବଳ ନୁହେଁ, ତାହା ସଭ୍ୟ ମନୁଷ୍ୟର ଏକ କର୍ତ୍ତବ୍ୟ ବୋଲି ମଧ୍ୟ କେବେହେଲେ ପ୍ରେରଣା ଦେଇନି, ସମସାମୟିକ ପ୍ରୟୋଜନ ଦୃଷ୍ଟିରୁ ତାହାର ମୂଲ୍ୟ କମିଯିବାର କଥା ।

1. ଆମ ସଂସ୍କୃତି କାହା ଉପରେ ଗୁରୁତ୍ୱ ଦିଏ ନାହିଁ ?
 (A) ବର୍ତ୍ତମାନର ଆବଶ୍ୟକତା
 (B) ଅତୀତ ଐତିହ୍ୟ
 (C) ପରମ୍ପରା
 (D) ଗତାନୁଗତିକତା
2. ବିଶ୍ୱ ସଂସ୍କୃତିକୁ କ'ଣ ଭାରତର ଦାନ ନୁହେଁ ?
 (A) ଧର୍ମ
 (B) ଦର୍ଶନ
 (C) କଳା
 (D) ପାର୍ଥବ ସୁଖ ପ୍ରଦାନକାରୀ ବସ୍ତୁ
3. ଆମ ସଂସ୍କୃତିର ଐତିହ୍ୟ କିପରି ?
 (A) ଯୁଗୋପଯୋଗୀ
 (B) ଯୁଗୋପଯୋଗୀ ନୁହେଁ
 (C) ପ୍ରେରଣା ଦାୟୀ
 (D) ପ୍ରଗତିଶୀଳ
4. ପାଶ୍ଚାତ୍ୟ ସମାଲୋଚକମାନେ ଭାରତୀୟମାନଙ୍କଠାରେ କାହାର ଅଭାବ ଲକ୍ଷ୍ୟ କରନ୍ତି ?
 (A) ପାରମ୍ପରିକତାର
 (B) ଗତାନୁଗତିକତାର
 (C) ମୌଳିକତାର
 (D) ଧାର୍ମିକତାର

5. ଭାରତୀୟ ଜୀବନଧାରାରେ ସାଧାରଣତଃ କ'ଣ ଦେଖାଯାଏ ?

- (A) ଗତାନୁଗତିକତା
(B) ମୌଳିକତା
(C) ସାମାଜିକତା
(D) ନୈତିକତା

6. ତୁଳସୀ ଦି' ପତ୍ରରୁ ବାସେ, ବିଛୁଆତି ଦି' ପତ୍ରରୁ କୁଣ୍ଡାଲ ହୁଏ । - ଏହା କେଉଁ ପ୍ରକାର ବାକ୍ୟ ?

- (A) ଯୌଗିକ
(B) ଜଟିଳ
(C) ସରଳ
(D) ମିଶ୍ର

7. ସବୁଟି ମିଛ ହରି ନାମଟି ସତ । - ଏଥିରେ 'ସବୁ' କେଉଁ ପଦ ?

- (A) ବିଶେଷ୍ୟ
(B) ବିଶେଷଣ
(C) ସର୍ବନାମ
(D) ଅବ୍ୟୟ

8. 'ନିରର୍ଥକ' - ଏହା କେଉଁ ସମାସ ନିଷ୍କ ପଦ ?

- (A) ବହୁରୂପୀ
(B) କର୍ମଧାରୟ
(C) ତତ୍ପୁରୁଷ
(D) ଦ୍ୱିଗୁ

9. 'ସଚାବତା କରି' ରୂପର ଅର୍ଥ କ'ଣ ?

- (A) କଷ୍ଟସାଧ୍ୟ
(B) କୌଣସି ମତେ
(C) ବୃଥା ପରିଶ୍ରମ
(D) ଅତି ପୁରୁଣା

10. ନିମ୍ନୋକ୍ତ ଶବ୍ଦଗୁଡ଼ିକ ମଧ୍ୟରୁ କେଉଁଟି 'ଅ' ପ୍ରତ୍ୟୟ ଯୁକ୍ତ ?

- (A) ଗବ୍ୟ
(B) ଦୈତ୍ୟ
(C) ବୈଦ୍ୟ
(D) ସୈନ୍ୟ

11. ଶୁଦ୍ଧ ଶବ୍ଦଟିକୁ ବାଛ :

- (A) ଚାକିରୀ
(B) ଭରଷା
(C) ଉପତ୍ୟାକା
(D) ସାରଥୀ

12. ଚନ୍ଦ୍ରପର ଯୋଗ୍ୟ - ସମସ୍ତ ପଦଟି କ'ଣ ?

- (A) ଅପରୂପ
(B) ଅନୁରୂପ
(C) ଯଥାରୂପ
(D) ପ୍ରତିରୂପ

13. ଭୂଲ ନଥିବା ବାକ୍ୟଟିକୁ ଚିହ୍ନାଅ :

- (A) ସେ ଅତିଥିମାନଙ୍କୁ ସବାନ୍ଧବେ ଆସିବାକୁ ନିମନ୍ତ୍ରିତ କଲେ ।
 (B) ଗୌତମ ମୃତ ଶବକୁ ଦେଖିବାପରେ ସନ୍ନ୍ୟାସୀ ହେବାକୁ ସ୍ଥିର କରିଥିଲେ ।
 (C) ଶିକ୍ଷାପ୍ରସାର ଦ୍ୱାରା ଜାତିର ସର୍ବାଙ୍ଗୀଣ ଉନ୍ନତି ସାଧିତ ହୁଏ ।
 (D) ଭିନ୍ନକ୍ଷମମାନଙ୍କୁ ସମ୍ମାନ କରିବାପାଇଁ ସରକାର ବହୁ ଯୋଜନାମାନ କରୁଛନ୍ତି ।

14. 'ରମଣୀୟ' ଶବ୍ଦଟି କେଉଁ କୃତ ପ୍ରତ୍ୟୟ ଦ୍ୱାରା ଗଠିତ ?

- (A) ଯ
 (B) ଅନୀୟ
 (C) ଈୟ
 (D) ଅଣୀୟ

15. ସତୀକି ତମସା ଅଙ୍କରେ

ଘେନି ସ୍ନେହେ ଆଲିଙ୍ଗିଲା ତରଙ୍ଗ-କରେ ।

- ଏଥିରେ କେଉଁ ଅଳଙ୍କାର ରହିଛି ?

- (A) ରୂପକ
 (B) ଉପମା
 (C) ଶ୍ଳେଷ
 (D) ଉତ୍ପ୍ରେକ୍ଷା

16. ନିମ୍ନ ପ୍ରଦତ୍ତ ଶବ୍ଦଗୁଡ଼ିକ ମଧ୍ୟରୁ କେଉଁ ଶବ୍ଦରେ ସ୍ୱାଭାବିକ ଭାବେ 'ଶ' ରହିଛି ?

- (A) ଶ୍ରବଣ
 (B) ଦ୍ୱିୟମାଣ
 (C) ନିର୍ଣ୍ଣୟ
 (D) ଲବଣ

17. ମନ୍ଦିରଟି ଦୁଇବର୍ଷରେ ତୋଳା ହେଲା । - ରେଖାଙ୍କିତ ପଦଟି କେଉଁ ବିଭକ୍ତି ?

- (A) ସପ୍ତମୀ
 (B) ପଞ୍ଚମୀ
 (C) ପ୍ରଥମୀ
 (D) ତୃତୀୟା

18. ସରେ ରସେ ଷଟପଦ ସାରସୀ- ରସରେ

ବୁଲେ ସଦା ଲବେ ସ୍ଥିର ନୋହି କା ପାଶରେ । - ଏଥିରେ କେଉଁ ଅଳଙ୍କାର ପ୍ରଯୁକ୍ତ ?

- (A) ଉପମା
 (B) ଶ୍ଳେଷ
 (C) ଅନୁପ୍ରାସ
 (D) ଉତ୍ପ୍ରେକ୍ଷା

19. 'ଉଠିଆ ଖାଇବା' ରୂପେ କେଉଁ ଅର୍ଥରେ ପ୍ରଚଳିତ ?

- (A) ରାଗିବା
 (B) ମାଗଣା ଖାଇବା
 (C) ଉପରେ ପଡ଼ି କହିବା
 (D) ଉନ୍ନତି ଉପରେ ଉନ୍ନତି

20. ଚୋରଟି ପୋଲିସ୍ କର୍ତ୍ତୃକ ଧରାହେଲା । - ରେଖାଙ୍କିତ ପଦଟି କେଉଁ ପ୍ରକାର ଅବ୍ୟୟ ?

- (A) ହେତୁବୋଧକ
 (B) ଭାବ ବାଚକ
 (C) ନିଶ୍ଚୟ ବୋଧକ
 (D) ବିଭକ୍ତି ସୂଚକ

12

A - SECTION - II
ENGLISH (COMPULSORY)

21. He turned _____ my proposal.

(Fill in the blank with the correct alternative)

(A) out

(B) down

(C) off

(D) up

22. It _____ since 8 O'clock in the morning.

(Fill in the blank with the correct alternative)

(A) is raining

(B) had rained

(C) has been raining

(D) rained

23. Which letter is silent in 'autumn' ?

(A) m

(B) n

(C) t

(D) a

24. If he studied hard, he _____ the first division.

(Complete the sentence choosing the correct alternative)

(A) will secure

(B) will have secured

(C) would have secured

(D) would secure

25. The Principal and Secretary _____ present at the meeting yesterday.

(Fill in the blank choosing the correct alternative)

(A) was

(B) were

(C) had

(D) is

26. The word 'debt' is pronounced as _____.

(A) /deit/

(B) /det/

(C) /dait/

(D) /debt/

27. He paid the dues _____ cheque.
(Fill in the blank with the correct preposition)

- (A) in
- ✓ (B) by
- (C) on
- (D) with

28. The diet is _____ in calcium.
(Fill in the blank with the correct alternative)

- (A) deficient
- ✓ (B) deficiency
- (C) deficit
- (D) deficiently

29. They made her chairman of the committee.

If the above sentence is changed into passive voice, it will be _____.

- (A) She is made chairman of the committee.
- ✓ (B) She was chairman made by the committee.
- (C) She was made chairman of the committee.
- (D) The chairman was made by them.

30. Which is the correct pronunciation of 'passed' ?

- (A) /pa:st/
- ✓ (B) /pa:sd/
- (C) /pa:sst/
- (D) /pa:stt/

Read the passage given below and answer the questions that follow choosing the correct alternatives given.

"Eat the right amount of the right food at the right time" is a food rule for everybody. Those who follow it usually notice the benefit in greater physical and mental efficiency, and more stamina and vigour. They add years to their life as well as vitality to their years.

Our body is the most wonderful engine of all, because it builds and repairs itself. It needs fuel, lubricants and other materials which we call food or nutrition, and this food should consist of minerals, carbohydrates, vitamins, fats and proteins.

31. What is regarded as the most wonderful engine ?

- (A) Our mind
- ✓ (B) Our body
- (C) Our heart
- (D) Our life

32. What should be followed for the benefit of greater physical and mental efficiency ?

- (A) Food rule
- (B) Instructions of the expert
- (C) Body's rule
- (D) Body-building rules

33. What is considered fuel or lubricant for the body ?

- (A) Stamina
- (B) Food
- (C) Rule
- (D) Efficiency

34. The food rule is that one has to eat the right amount of the right food at _____.

- (A) all times
- (B) night
- (C) lunch
- (D) the right time

35. The antonym of 'efficiency' is _____.

- (A) sufficiency
- (B) deficient
- (C) inefficiency
- (D) unefficiency

Read the poem carefully and answer the questions that follow choosing correct alternatives.

The rose that smiles today,

Though beautiful and gay

Will shortly fade away

The mountains looming high

That seem to kiss the sky,

Will some day crumbled lie.

The rolling oceans wide,

One thinks will e'er abide

Will once be emptied, dried.

The earth so firm and vast,

Today that rolls so fast,

Will cease to be at last.

Each star now shining bright;

That meets thy wondering sight,

Will one day lose its light.

Then midst thy grief be gay,

For long it will not stay,

That too will pass away.

36. Which will be emptied and dried ?

(A) The mountains

(B) The earth

(C) The rose

~~(D) The oceans~~

37. The expression 'That' used in the last line of the poem refers to _____.

(A) beauty

(B) grief

(C) the rose

(D) the mountains

38. What will happen to the mountains one day ?

(A) They will fade away.

(B) They will lie crumbled.

(C) They will be emptied.

(D) They will kiss the sky.

1023491

39. The final message of the poet is that everything _____.

~~(A) will pass away~~

(B) is godly

(C) is permanent

(D) is unchangeable

40. The rose is described as _____.

(A) beautiful and grave

(B) grave and gay

~~(C) beautiful and bright~~

~~(D) beautiful and gay~~

7

B - SECTION - III
SCIENCE (PCM)
PHYSICS

41. A projectile is fired from the ground level with a speed of 18 m/s at an angle of 60° with the horizontal. After 1 second, a second projectile is fired from the same place with a speed of 10 m/s at an angle 45° with the horizontal. When both the projectiles are in flight, the relative acceleration of the second projectile with respect to the first is :

- (A) 16 m/s^2
- ~~(B) 5.6 m/s^2~~
- (C) -5.6 m/s^2
- (D) zero

42. The torque about the point $O(3, -1)$ of a force $\vec{F} (2, 4) \text{ N}$ on a plane X-Y passing through the point $A(5, 2)$ is :

(the co-ordinates of the point O and A are in meter)

- (A) $2 \hat{k} \text{ N.m}$
- ~~(B) $-2 \hat{k} \text{ N.m}$~~
- ~~(C) $14 \hat{k} \text{ N.m}$~~
- (D) $-14 \hat{k} \text{ N.m}$

43. A planet is at distance 'a' from the sun and its time period of revolution is T yrs.

The planet suddenly comes to distance $\frac{a}{2}$ closer to the sun. The new time period of revolution is :

- (A) $\frac{T}{2} \text{ yrs}$
- (B) $\frac{T}{2\sqrt{2}} \text{ yrs}$
- (C) $\sqrt{2} T \text{ yrs}$
- (D) $2\sqrt{2} T \text{ yrs}$

44. A transverse wave of frequency 16 Hz travels along a straight string. Two points 4 m apart along the string have a phase difference of 120° . The wavelength of the travelling wave is :

- (A) 4 m
- ~~(B) $\frac{8}{3} \text{ m}$~~
- (C) 64 m
- (D) 12 m

45. The focal length of a convex lens is 20 cm. The minimum distance between an object and its real image formed by the lens is :

- ~~(A) 40 cm~~
- (B) 80 cm
- (C) 60 cm
- (D) 20 cm

46. A bat at rest sends out ultrasonic sound waves at 34 kHz and receives them returned from the object. If the bat is moving away from the object at 5 m/s and the velocity of sound is 335 m/s, what is the apparent frequency heard by the bat ?

- (A) 33 kHz
- (B) 60 kHz
- (C) 32 kHz
- (D) 75 kHz

47. The length of a wire of uniform cross-section changes from L_1 to L_2 when the tensile force on it changes from T_1 to T_2 . The relaxed length of the wire is :

- (A) $\frac{1}{2} (L_1 + L_2)$
- (B) $\frac{L_1 T_2 + L_2 T_1}{T_1 + T_2}$
- (C) $\frac{L_1 T_2 + L_2 T_1}{\sqrt{T_1 T_2}}$
- (D) $\frac{T_1 L_2 - T_2 L_1}{T_1 - T_2}$

48. The capacitance of a spherical liquid drop is $2 \mu\text{F}$. One thousand such identical drops coalesce to form a large single spherical drop. The capacitance of the large drop is :

- (A) $2000 \mu\text{F}$
- (B) $500 \mu\text{F}$
- (C) $20 \mu\text{F}$
- (D) $2 \mu\text{F}$

49. An air bubble of radius 'r' doubles its radius as it rises from a depth 'h' to the surface of the lake at a constant temperature. If the atmospheric pressure is equal to 10 m height of the water column, neglecting surface tension the value of 'h' is :

- (A) 90 m
- (B) 70 m
- (C) 60 m
- (D) None of these

50. A concave mirror of focal length 10 cm and a convex mirror of focal length 15 cm are placed facing each other 40 cm apart. A point object is placed between the mirrors on their common axis at a distance of 15 cm from the concave mirror. Find the position of the image produced by the successive reflections, first at the concave mirror and then at the convex mirror.

- (A) 6 cm behind the convex mirror
- (B) 4.28 cm behind the convex mirror
- (C) 6 cm in front of the convex mirror
- (D) 4.28 cm in front of the convex mirror

51. One mole of an ideal monatomic gas requires 210 J heat to raise its temperature by 10 K when heated at constant pressure. If the same gas is heated at constant volume to raise the temperature by the same amount, the heat required is :

- (A) 108.7 J
- (B) 115.3 J
- (C) 129 J
- (D) 126 J

52. The equivalent capacitance between the points P and Q in the circuit given below is :

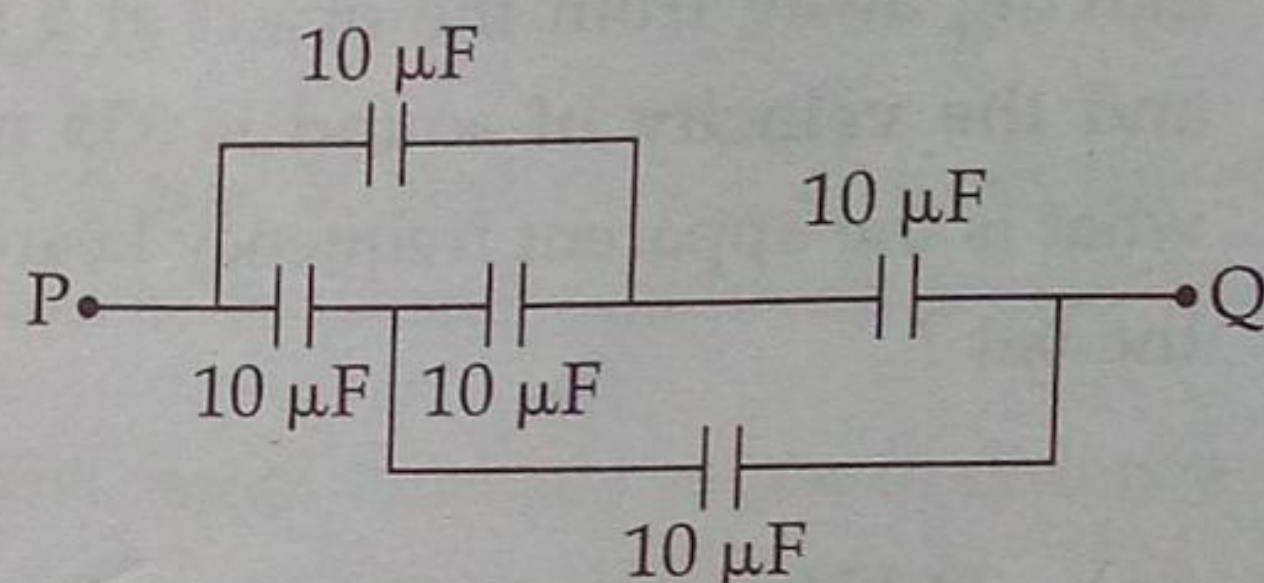

- (A) 40 μF
- (B) zero
- (C) 0.1 μF
- (D) 10 μF

53. In an astronomical telescope, the power of the objective is 0.5 D and that of the eye piece is 20 D. The magnifying power of the telescope is :

- (A) 10
- (B) 100
- (C) 35
- (D) 40

54. A geostationary satellite revolves around the earth :

- (A) in an orbit whose plane passes through the north pole and the south pole of the earth.
- (B) twice in 24 hours.
- (C) at an altitude of about 200 km above the surface of the earth.
- (D) in an orbit whose plane passes through the equator of the earth.

55. A body is dropped from rest, while at the same instant a second body is thrown downwards with an initial velocity of 1 m/s. When will the distance between them be 18 m ?

- (A) 3 s
- ✓ (B) 1.8 s
- ✗ (C) 18 s
- (D) 12 s

56. The maximum current I which can pass through a fuse wire of circular cross-section without melting it varies with its radius ' r ' as :

- (A) $I \propto r$
- ✓ (B) $I \propto r^{3/2}$
- ✗ (C) $I \propto r^2$
- ✗ (D) $I \propto \frac{1}{r^2}$

57. An ideal transformer is used on 220 V line to deliver 2 A at 110 V. The current through the primary is :

- ✗ (A) 10 A
- ✗ (B) 5 A
- ✓ (C) 1 A
- (D) 0.1 A

58. In a given electrical circuit, a 10Ω resistor is parallel to a 5Ω resistor. The ratio of the heat produced in the first resistor to that in the second resistor is :

- ✓ (A) 1 : 2
- ✗ (B) 2 : 1
- ✗ (C) 1 : 4
- (D) 4 : 1

59. In a series LCR circuit, the voltage across each resistor, inductor and capacitor is 10 volt. If the resistance is short circuited, the current in the circuit becomes :

- ✗ (A) Zero
- ✗ (B) Very large
- (C) 10 A
- (D) 5 A

60. Which of the following is a unit of self inductance ?

- (A) weber per ampere
- ✗ (B) volt second per ampere
- (C) joule per ampere
- ✓ (D) ohm second

B - SECTION - III
SCIENCE (PCM)
CHEMISTRY

61. In a vessel 4 g of O_2 , 4 g of H_2 , 4 g of N_2 and 4 g of Cl_2 are present. Which of these gases has highest number of atoms ?
 (A) O_2
 (B) H_2
 (C) N_2
 (D) Cl_2
62. Which of the following aqueous solution will have highest elevation of boiling point ?
 (A) 1 M NaOH
 (B) 1 M Na_2SO_4
 (C) 1 M NH_4NO_3
 (D) 1 M KNO_3
63. The quantum numbers n and l for four electrons are given below.
 (i) $n=4, l=1$
 (ii) $n=4, l=0$
 (iii) $n=3, l=2$
 (iv) $n=3, l=1$
 The order of their energy from lowest to highest is :
 (A) (iii) < (i) < (iv) < (ii)
 (B) (i) < (ii) < (iii) < (iv)
 (C) (ii) < (iv) < (i) < (iii)
 (D) (iv) < (ii) < (iii) < (i)
64. When two ice cubes are pressed over each other, they unite to form one cube. Which of the force is responsible to hold them together ?
 (A) Hydrogen bond formation
 (B) van der Waal's forces
 (C) Covalent attraction
 (D) Ionic interaction
65. The volume of carbon dioxide gas at NTP obtained by heating 4.2 g of $MgCO_3$ would be :
 (At. mass of Mg = 24, O = 16, C = 12)
 (A) 22.4 litres
 (B) 11.2 litres
 (C) 1.12 litres
 (D) 2.24 litres
66. The de-Broglie wavelength of a particle of mass 0.001 kg and moving with velocity 100 m/s is given by :
 (A) 6.62×10^{-34} m
 (B) 6.62×10^{-33} m
 (C) 6.62×10^{-35} m
 (D) 6.62×10^{-32} m
67. Nitrogen gas is kept in a 1 litre flask under 100 kPa pressure and oxygen gas is kept in another 3 litre flask under 320 kPa pressure. If the two flasks are connected the resultant pressure of the mixture of gases will be :
 (A) 310 kPa
 (B) 210 kPa
 (C) 365 kPa
 (D) 265 kPa

68. The element having which of the following electronic configuration will have highest ionization energy ?

- (A) [Ne] $3s^2 3p^1$
 ✓ (B) [Ne] $3s^2 3p^3$
 (C) [Ne] $3s^2 3p^2$
 (D) [Ne] $3s^2 3p^4$

69. The shape of NH_3 molecule and hybridisation of the central atom of NH_3 molecule is :

- (A) Linear and sp
 (B) Trigonal planar and sp^2
 ✗ (C) Pyramidal and sp^3
 ✓ (D) Tetrahedral and sp^3

70. The outermost electronic configuration of most electronegative elements is :

- (A) $ns^2 np^3$
 ✗ (B) $ns^2 np^4$
 ✓ (C) $ns^2 np^6$
 (D) $ns^2 np^5$

71. The oxidation number of sulphur in S_8 , S_2F_2 and H_2S respectively are :

- (A) +2, +1, -2
 ✓ (B) -2, +1, -2
 (C) 0, +1, +2
 (D) 0, +1, -2

72. Find the concentration of HCl if 10 ml of 0.5 M $\text{Ca}(\text{OH})_2$ solution is required to titrate 50 ml of HCl till the neutralization point.

- (A) 5 M
 ✓ (B) $\frac{1}{10}$ M
 ✗ (C) 10 M
 ✗ (D) $\frac{1}{5}$ M

73. In the reaction

$\text{PCl}_5(\text{g}) \rightleftharpoons \text{PCl}_3(\text{g}) + \text{Cl}_2(\text{g})$, the equilibrium concentration of PCl_5 and PCl_3 are 0.4 and 0.2 mole/litre respectively. If the value of K_c is 0.5, what is the concentration of Cl_2 in mole/litre ?

- (A) 2.0
 ✗ (B) 1.5
 ✓ (C) 1.0
 (D) 0.5

74. When copper pyrite is roasted in excess of air, a mixture of CuO and FeO is formed. FeO is present as impurity. This can be removed as slag during reduction of CuO to Cu . The flux that is added to form the slag is :

- ✓ (A) SiO_2 , which is an acidic flux
 ✗ (B) Limestone, which is a basic flux
 ✗ (C) SiO_2 , which is a basic flux
 (D) CaO , which is a basic flux

75. At 90°C , pure water has $[\text{H}_3\text{O}^+] = 10^{-6} \text{ M}$. What is the value of K_w at this temperature?

- (A) 10^{-6}
 (B) 10^{-12}
 (C) 10^{-13}
 (D) 10^{-14}

76. The IUPAC name of which of the following compounds is wrong?

(A) $\text{CH}_3\text{CH}_2\text{CH}_2\text{COOCH}_2\text{CH}_3 \rightarrow$
 Ethyl butanoate

(B) $\text{CH}_3 - \underset{\text{CH}_3}{\text{CH}} - \text{CH}_2\text{CHO} \rightarrow$
 3-Methyl butanal

(C) $\text{CH}_3 - \underset{\text{OH}}{\text{CH}} - \underset{\text{CH}_3}{\text{CH}} - \text{CH}_3 \rightarrow$
 2-Methyl butan-3-ol

(D) $\text{CH}_3 - \underset{\text{CH}_3}{\text{CH}} - \underset{\text{O}}{\text{C}} - \text{CH}_2 - \text{CH}_3 \rightarrow$
 2-Methyl propan-3-one

77. Anti-Markownikoff's addition of HBr in presence of an organic peroxide is not observed in:

- (A) Propene
 (B) But-1-ene
 (C) But-2-ene
 (D) Pent-2-ene

78. What will be the product of the following reaction?

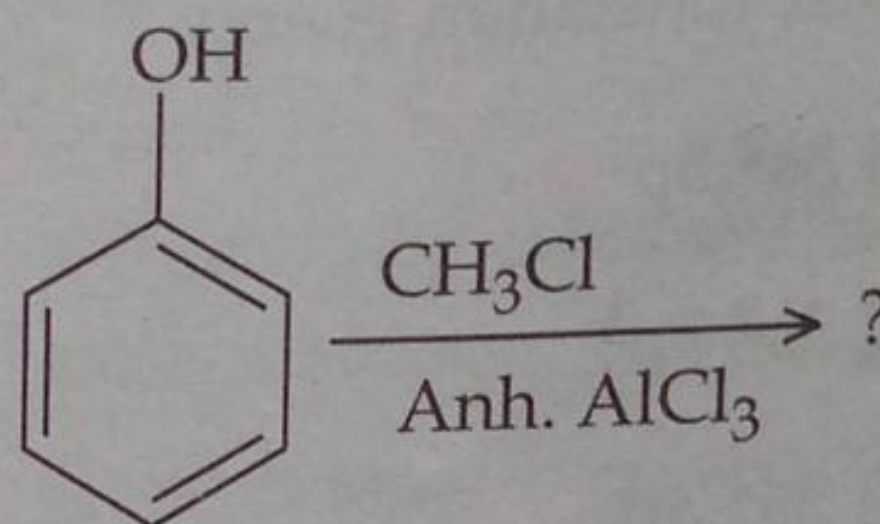

- (A) m-hydroxy toluene
 (B) m-chlorophenol
 (C) o-chlorophenol and p-chlorophenol
 (D) o-hydroxy toluene and p-hydroxy toluene

79. The order of decreasing stability of the following carbanions is:

- (i) $(\text{CH}_3)_3\text{C}^{\ominus}$
 (ii) $(\text{CH}_3)_2\text{CH}^{\ominus}$
 (iii) $\text{CH}_3\text{CH}_2^{\ominus}$
 (iv) $\text{C}_6\text{H}_5\text{CH}_2^{\ominus}$

- (A) (i) > (ii) > (iii) > (iv)
 (B) (iv) > (iii) > (ii) > (i)
 (C) (iv) > (ii) > (i) > (iii)
 (D) (i) > (ii) > (iv) > (iii)

80. Which method of purification is represented by the following equations?

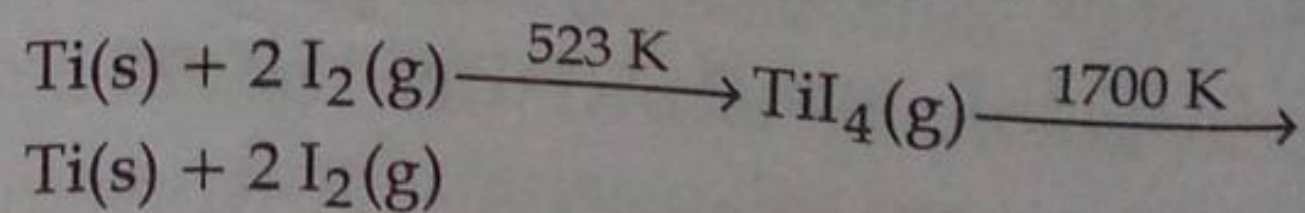

- (A) Cupellation
 (B) Poling
 (C) Zone refining
 (D) Van Arkel Method

B - SECTION - III
SCIENCE (PCM)
MATHEMATICS

81. Let U be the universal set and $A \cup B \cup C = U$. Then $\{(A - B) \cup (B - C) \cup (C - A)\}'$ is equal to :

- (A) $A \cup B \cup C$
- (B) $A \cup (B \cap C)$
- (C) $A \cap B \cap C$
- (D) $A \cap (B \cup C)$

82. If α and β are the roots of the equation $x^2 - k(x+1) - c = 0$, the value of $(\alpha+1)(\beta+1)$ is equal to :

- (A) 1
- (B) $k \pm c$
- (C) $1 - c$
- (D) $1 + c$

83. Let $f: R \rightarrow R$ be defined as $f(x) = x^4$. Choose the correct option from the following :

- (A) f is one-one onto
- (B) f is many-one onto
- (C) f is one-one but not onto
- (D) f is neither one-one nor onto

84. Out of four integers, any three were randomly taken at a time and added. The results were found to be 174, 193, 267 and 242. Which of the following integers is the greatest among these four ?

- (A) 118
- (B) 127
- (C) 99
- (D) 123

85. Let R be the relation in the set N given by $R = \{(a, b) : a = b - 2, b > 6\}$, then :

- (A) $(2, 4) \in R$
- (B) $(3, 8) \in R$
- (C) $(6, 8) \in R$
- (D) $(8, 7) \in R$

86. The interval in which $y = x^2 e^{-x}$ is increasing is :

- (A) $(-\infty, \infty)$
- (B) $(-2, 0)$
- (C) $(2, \infty)$
- (D) $(0, 2)$

87. The terms of a G.P. are all positive and each term of it is equal to the sum of the next two following terms. Find its common ratio.

- (A) $\frac{1}{\sqrt{5}}$
- (B) $\frac{\sqrt{5}+1}{2}$
- (C) $\frac{1}{1+\sqrt{5}}$
- (D) $\frac{\sqrt{5}-1}{2}$

88. What will be the common difference of the arithmetic progression, whose sum of first m terms is given by $2(m^2 + 3m)$?

- (A) 12
- (B) 10
- (C) 9
- (D) 4

89. The total revenue in rupees received from the sale of x units of a product is given by $R(x) = 3x^2 + 36x + 5$. The marginal revenue, when $x = 15$ is :

- (A) 90
- (B) 96
- (C) 116
- (D) 126

90. A monoid is called a group if :

- (A) $(a * a) = a = (a + c)$
- (B) $(a * c) = (a + c)$
- (C) $(a + c) = a$
- (D) $(a * c) = (c * a) = e$

91. If the lines $\frac{x + 2}{4\lambda + 1} = \frac{y - 1}{4} = \frac{z}{-18}$ and

$\frac{x}{-3} = \frac{y + 1}{5\mu - 3} = \frac{z - 1}{6}$ are parallel to

each other then the value of the pair (λ, μ) is :

- (A) $(-2, \frac{1}{3})$
- (B) $(2, -\frac{1}{3})$
- (C) $(2, \frac{1}{3})$
- (D) Cannot be found

92. A point R with x Co-ordinate 4 lies on the line segment joining the points $P(2, -3, 4)$ and $Q(8, 0, 10)$. Find the Co-ordinate of the point R.

- (A) $(2, 0, -4)$
- (B) $(4, -2, 6)$
- (C) $(4, 2, 6)$
- (D) $(5, -2, 1)$

93. Two students A and B appeared in an examination. The probability that A will qualify the examination is 0.05 and that B will qualify the examination is 0.1. The probability that both will qualify the examination is 0.02. Find the probability that both A and B will not qualify the examination.

- (A) 0.11
- (B) 0.15
- (C) 0.87
- (D) 0.98

94. The variance of 20 observations is 5. If each observation is multiplied by 2, find the variance of the resulting observations.

- (A) 10
- (B) 20
- (C) 40
- (D) 5

95. A circle of radius 5 units touches the Co-ordinate axes in the first quadrant. If the circle makes one complete roll on x-axis along the positive direction of x-axis, find its equation in new position.

- (A) $x^2 + (y - 5)^2 = 5^2$
- (B) $x^2 + \{y - (5 + 10\pi)\}^2 = 5^2$
- ✓ (C) $\{x - (5 + 10\pi)\}^2 + (y - 5)^2 = 5^2$
- (D) $\{x + (5 - 10\pi)\}^2 + y^2 = 5^2$

96. A cylinder is of height 31 cm and base radius 7 cm. A hemisphere of radius equal to base radius of cylinder is cutoff from one end and a cone of maximum height from remaining part is also cutoff. The curved surface area of the remaining part is :

- ✓ (A) 506 cm²
- ✗ (B) 508 cm²
- (C) 510 cm²
- (D) 512 cm²

97. What is the value of $1 - \cos^2\alpha - \cos^4\alpha$, if $\sin\alpha + \sin^2\alpha = 1$?

- ✓ (A) 0
- ✗ (B) 1
- (C) 2
- (D) -1

98. If α and β are the solutions of $a\cos\theta + b\sin\theta = c$, then what will be the value of $\sin\alpha \cdot \sin\beta$?

- (A) $\frac{c^2}{a^2 + b^2}$
- ✗ (B) $\frac{a^2 + c^2}{a^2 - b^2}$
- ✗ (C) $\frac{c^2 - a^2}{a^2 + b^2}$
- (D) 1

99. The radius of a cylindrical container is 14 cm and height is 5 cm. By how many centimeters should the radius or the height be increased, so that the increase in volume becomes the same (not zero) in either case ?

- (A) 9.4 cm
- (B) 9.8 cm
- ✗ (C) 10.4 cm
- ✓ (D) 11.2 cm

100. Let $A = \begin{vmatrix} 1 & \sin\theta & 1 \\ -\sin\theta & 1 & \sin\theta \\ -1 & -\sin\theta & 1 \end{vmatrix}$, where

$0 \leq x \leq 2\pi$, then :

- ✗ (A) Det A = 0
- ✓ (B) Det A \in [2, 4]
- (C) Det A belongs to (1, 4)
- (D) None of these

C - SECTION - IV
**CHILD DEVELOPMENT, PEDAGOGY,
 SCHOOL MANAGEMENT & EVALUATION**

101. Which of the following is not a characteristics of learner-centric learning ?
- (A) Teacher and students evaluate learning together.
 - ✓ (B) Teaching leads to increase student learning and long-term retention.
 - (C) Approach is compatible with interdisciplinary investigation.
 - (D) Emphasis is on communicating knowledge effectively.

102. Who said curriculum is a written plan ?
- (A) Ragan
 - ✗ (B) Tylor
 - ✓ (C) Albert
 - ✓ (D) Smith, Stanley and Shore

103. The following statements are the function of SMC except :
- (A) Review coverage of courses/studies.
 - ✓ (B) Supervise the daily instructional activities.
 - ✗ (C) Intimate the PTA and the District Officer about the grants received and utilisation thereof.
 - ✓ (D) Monitor the identification and enrolment of and facilities for learning by disabled children.

104. To maximize the return on investment from the organisation's human capital and minimize financial risk is the objective of :
- (A) Physical Resources
 - ✓ (B) Human Resources
 - ✗ (C) Financial Resources
 - (D) Community Resources

105. A child is talking with his friend and says, "Mine is gooder". Which theory of language acquisition best explains the use of "gooder" ?
- (A) Skinner theory
 - ✗ (B) Social cognitive theory
 - (C) Noam Chomsky's theory
 - ✓ (D) None of the above theory

106. According to Socio-cultural theory of Vygotsky :
- (A) The child thinks in different domains does not take a complete perspective.
 - ✓ (B) Culture and language play a crucial role in development.
 - ✗ (C) Children think in abstract terms if presented abstract material at a lower age.
 - (D) Self-directed speech is the lowest stage of the scaffold.

107. "The need and purpose of educational management is to enable the right pupils to receive the right education from the right teachers." - who said it?

(A) Graham Balfour

(B) Kandel

X (C) J.B. Thomas

(D) Shelly Umans

108. Which theory of concept learning use the characteristics of concepts to define them?

(A) Prototype theory

(B) Rule-Driven theory

X (C) Exemplar theory

(D) Both (A) and (C)

109. According to Lawrence Kohlberg's theory of moral development, at which stage, people make decisions based on loyalty, living upto the expectations of others and social conventions:

(A) Social Contract

(B) Interpersonal Harmony

X (C) Universal Principles

(D) Law and Order

110. Which of the following Sternberg's theory of intelligence focuses on academic proficiency?

(A) Componential sub-theory

(B) Experimental sub-theory

X (C) Contextual sub-theory

(D) All of the above

111. In which stage of cognitive development a child can think logically about objects?

(A) Sensori-motor

(B) Pre-operational

(C) Concrete operational

(D) Formal operational

112. Riyu is a tenth class student in your history class. She seems to have a good understanding of the content, that is, she can recite for you the dates and places of the events you have covered in class. However, when you ask the class to defend a point, she often uses the wrong information to support her points. Riyu most likely needs help in increasing her _____.

(A) Prior Knowledge

(B) Procedural Knowledge

X (C) Declarative Knowledge

(D) Conditional Knowledge

113. The degree to which an assessment actually measures what it is supposed to measure is known as :

- (A) Validity
- (B) Reliability
- (C) Practicality
- (D) Ethics

114. In a constructivist classroom as envisioned by Piaget and Vygotsky learning :

- (A) Is dictated by the teacher and the students are passive recipient of the same
- (B) Happens by pairing of stimulus and a response
- (C) Is offering of reinforcement by the teacher
- (D) Is constructed by the students themselves who play an active role

115. The teacher can utilize both 'assessment for learning' and 'assessment of learning' to :

- (A) Monitor children's progress and set appropriate goals to fill their learning gaps.
- (B) Know children's progress and achievement level.
- (C) Know learning needs of child and select teaching strategy accordingly.
- (D) Assess children's performance at periodic intervals and certify his/her performance.

116. NCF-2005 proposes the evaluation system should be based on :

- (A) Grades
- (B) Marks
- (C) Portfolios
- (D) Both (A) and (B)

117. "To provide a common platform for the state and the centre to share their views about improving educational standards." -is one of the objectives of :

- (A) NCERT
- (B) CET
- (C) CABE
- (D) NIEPA

118. In learning, assessment is essential for :

- (A) Grades and marks
- (B) Screening test
- (C) Motivation
- (D) Fostering the purpose of segregation and ranking

119. Who believed that every person could achieve their goals, wishes and desires in life, when or rather if they did so, self actualisation took place ?

- (A) Jean Piaget
- (B) Carl Rogers
- (C) Erik Erikson
- (D) Robert J. Sternberg

120. "Leadership motivates the people to work and not the power of money". This concept is related to :

- (A) Supportive model
- (B) Custodial model
- (C) Autocratic model
- (D) Collegial model

121. According to Psychologist Adams, the learning and forgetting is :

- (A) Forgetting means failure at any time to recall
- (B) Forgetting is failing to retain
- (C) Forgetfulness is voluntary
- (D) True learning is judicious forgetting

122. Which component represent the actual mental processes used for the execution of a task like task perception, concept identification and response making ?

- (A) Meta component
- (B) Component sub-theory
- (C) Performance component
- (D) Knowledge acquisition components

123. The benefits of formative assessment include all of the following except :

- (A) Guides teachers in deciding what they "need to do tomorrow" in terms of instruction
- (B) Provides various scores for teachers to average into a grade
- (C) Gives teachers the opportunity to make immediate adjustments in their instruction
- (D) Provides feedback to help students adjust and improve their performance

124. Which approach of management stands for the function of elimination of waste in all forms ?

~~(A)~~ Gist benefit approach

~~(B)~~ Manpower approach

(C) Social justice approach

(D) None of the above

125. The followings are the characteristics of self learning except :

(A) Can fulfill the needs of the student

~~(B)~~ The programmed instruction method reduces the problems of the group learning

(C) Stimulus - Response in this method motivate the students

~~(D)~~ None of these

126. Why might a teacher chose to use an analytic rubric for his/her students oral presentation ?

(A) Because he/she wants to judge the presentation as a whole

(B) Because he/she wants to use a rubric that can be created quickly

~~(C)~~ To give the students specific feedback

(D) To grade the presentation quickly

127. The first column for which matching is made is called as :

(A) Option

(B) Premises

~~(C)~~ Responses

(D) Direction

128. The following are the characteristics of mental development in adolescence except :

(A) Ability of problem solving

(B) Self-criticism and evaluation

(C) Symbolic and pre-conceptual thought

(D) Increased rational self-control

129. Who viewed intelligence as how well an individual deals with environmental changes throughout their life span ?

~~(A)~~ Robert J. Sternberg

(B) J.P. Guilford

(C) Noam Chomsky

(D) Lev Vygotsky

130. Which type of attention involves the ability to pay attention to two sets of stimuli at the same time ?

- (A) Selective attention
- (B) Divided attention
- (C) Adapted attention
- (D) Bi-directed attention

131. The second MLE Workshop (2006) was conducted for :

- (A) Preparation of curriculum.
- (B) Identifying the themes as per national curriculum.
- (C) Preparation of instructional materials in ten languages.
- (D) All of the above.

132. Which of the following is not a merit of small group learning ?

- (A) The level of achievement increases
- (B) It enhances the leadership quality
- (C) It clears the doubts in learning immediately
- (D) Motivation is developed among the learners

133. A teacher makes use of a variety of tasks to cater to the different learning styles of his/her learners. He/she is influenced by :

- (A) Gardner's multiple intelligence theory
- (B) Vygotsky's socio-cultural theory
- (C) Piaget's cognitive development theory
- (D) Kohlberg's moral development theory

134. Which of the following is the first decision that needs to be made when developing a portfolio ?

- (A) What goes in it ?
- (B) How and when are the entries selected ?
- (C) What should it look like ?
- (D) How is the portfolio evaluated ?

135. The content of a portfolio is largely based on :

- (A) The goal and purpose of the portfolio
- (B) The characteristics of the student evaluated
- (C) The length of the portfolio
- (D) None of the above

136. Which of the following is used as a guideline for designing a grading system ?

- (A) Create a system that is clear, understandable and consistent with school.
- (B) Base grades on observable data.
- (C) Assign grades consistently regardless of gender, class or socio-economic status.
- (D) All of the above

137. Art is a very effective medium of :

- (A) Exposure to social phenomenon
- (B) Self-expression and communication
- (C) Development of moral values in life
- (D) Expressing the hidden knowledge within the child

138. Which of the following is not a merit of learning centered approach ?

- (A) Learners find interest in learning
- (B) It fosters in learners a sense of co-operation
- (C) Students mostly depend on teachers
- (D) Emotional problems of learners are properly channelised

139. Which of the following does not refer to Vygotsky's theory of the zone of proximal development ?

- (A) The range of problem, a child can solve if given some assistance.
- (B) Children cognition remains limited by pre-operational mode of understanding.
- (C) Children acquire cognitive structure from cultural and social interactions.
- (D) Parent and teachers can foster cognitive development.

140. The concept of 'accommodation' in Piaget's development scheme implies :

- (A) That these are cognitive structures.
- (B) Incorporation of something new in the environment.
- (C) Modification or change of an old scheme to learn a new scheme.
- (D) Maintaining balance between child and changing equilibrium.

141. Development of self assessment and peer assessment skills fall into which category ?

- (A) Assessment for learning
- (B) Assessment as learning
- (C) Assessment of learning
- (D) All of the above

142. Which of the following is an advantage of peer assessment ?

- (A) Peer pressure and friendship can influence the reliability of grades
- (B) It enhances the time and workload of marking for teachers
- (C) Students learn how to criticise, evaluate and apply other generic skills during the process
- (D) Extroverted students can be marked higher

143. Who developed a theory of motivation called drive-reduction theory of reinforcement ?

- (A) E.L. Thorndike
- (B) Kurt Lewin
- (C) Harry Harlow
- (D) Clark L. Hull

144. Assessment and Examination should :

- (A) Access children's ability to recall text-book language.
- (B) Access according to the answer given in guide-book.
- (C) Access children's ability to use his/her knowledge for problem solving and its application in the real world.
- (D) Access by fixed rules of marking and ranking.

145. According to NCF-2005 the purpose of evaluation is not :

- (A) to motivate children to study under threat
- (B) to label the children as slow learners
- (C) to identify child who requires remediation
- (D) all of the above

146. According to Erikson's theory, industry Vs inferiority conflict is found at which stage ?

- (A) School age
- (B) Early childhood
- (C) Adolescence
- (D) Adulthood

147. Authoritarian model is more suitable for :

- (A) Discipline
- (B) Confidence
- (C) Achievement
- (D) Improvement

148. Which of the following characteristics is not reflective of a cognitive view of learning ?

- (A) Changes in knowledge lead to changes in behaviour.
- (B) The outcome of learning is an observable behaviour.
- (C) Reinforcement is seen as information.
- (D) Humans are active learners.

149. The chief responsibility of the Headmaster is to :

- (A) Maintain school records
- (B) Handle discipline problems
- (C) Provide leadership in instructional plan
- (D) Organise and administer the guidance program

150. CCE includes :

- (A) Placement evaluation
- (B) Formative evaluation
- (C) Summative evaluation
- (D) Evaluation of both cognitive and co-cognitive area

- o o o -

Date of Exam-01-09-2021



[PROVISIONAL]

BOARD OF SECONDARY EDUCATION:ODISHA:CUTTACK
OSSTET-2021
 SCORING KEY

PAPER-II
SET-A

COMPULSORY (SECTION- I & II)(ODIA & ENGLISH)							
Q.NO	ANS	Q.NO	ANS	Q.NO	ANS	Q.NO	ANS
1	B	11	C	21	B	31	D
2	B	12	C	22	D	32	A
3	A	13	D	23	A	33	B
4	D	14	B	24	B	34	B
5	B	15	D	25	C	35	*G*
6	B	16	A	26	C	36	B
7	C	17	D	27	A	37	A
8	A	18	A	28	D	38	B
9	D	19	B	29	C	39	D
10	B	20	A	30	B	40	B

COPTIONAL (SECTION- III) (PHYSICAL EDUCATION)											
Q.NO	ANS	DQ.NO	ANS	Q.NO	ANS	Q.NO	ANS	Q.NO	ANS	Q.NO	ANS
41	B	51	A	61	C	71	B	81	C	91	D
42	B	52	C	62	D	72	B	82	B	92	D
43	C	53	C	63	B	73	B	83	B	93	A
44	A	54	C	64	*G*	74	D	84	C	94	C
45	D	55	D	65	C	75	A	85	C	95	C
46	B	56	D	66	B	76	A	86	D	96	B
47	D	57	A	67	C	77	A	87	B	97	D
48	A	58	D	68	D	78	B	88	C	98	C
49	C	59	B	69	B	79	D	89	C	99	D
50	C	60	A	70	B	80	D	90	C	100	D

COMPULSORY (SECTION- IV)(CHILD DEVP., PEDAGOGY, S MANAGEMENT & EVLN.)									
Q.NO	ANS	Q.NO	ANS	Q.NO	ANS	Q.NO	ANS	Q.NO	ANS
101	B	111	D	121	D	131	A	141	D
102	D	112	D	122	B	132	A	142	C
103	C	113	B	123	D	133	B	143	C
104	D	114	C	124	D	134	B	144	A
105	D	115	C	125	B	135	D	145	A
106	A	116	C	126	A	136	A	146	C
107	C	117	C	127	B	137	A	147	D
108	D	118	D	128	C	138	B	148	A
109	C	119	A	129	D	139	C	149	C
110	A	120	A	130	B	140	C	150	A

Date of Exam-01-09-2021



[PROVISIONAL]

BOARD OF SECONDARY EDUCATION:ODISHA:CUTTACK

OSSTET-2021
SCORING KEY

PAPER-II

SET-B

COMPULSORY (SECTION- I & II) (ODIA & ENGLISH)

Q.NO	ANS	Q.NO	ANS	Q.NO	ANS	Q.NO	ANS
1	A	11	B	21	B	31	A
2	B	12	B	22	B	32	B
3	B	13	D	23	C	33	D
4	B	14	D	24	D	34	B
5	D	15	B	25	A	35	B
6	A	16	C	26	A	36	*G*
7	D	17	B	27	D	37	D
8	A	18	D	28	B	38	A
9	C	19	A	29	C	39	B
10	A	20	C	30	C	40	B

OPTIONAL (SECTION- III) (PHYSICAL EDUCATION)

Q.NO	ANS	Q.NO	ANS	Q.NO	ANS	Q.NO	ANS	Q.NO	ANS	Q.NO	ANS
41	B	51	B	61	B	71	C	81	A	91	A
42	C	52	*G*	62	B	72	A	82	A	92	A
43	D	53	C	63	D	73	D	83	D	93	B
44	D	54	D	64	C	74	B	84	A	94	C
45	C	55	C	65	B	75	A	85	D	95	B
46	B	56	B	66	D	76	B	86	A	96	D
47	B	57	D	67	D	77	B	87	D	97	B
48	C	58	D	68	C	78	C	88	A	98	D
49	C	59	B	69	D	79	C	89	C	99	C
50	C	60	C	70	C	80	B	90	D	100	C

COMPULSORY (SECTION- IV) (CHILD DEVP., PEDAGOGY, S MANAGEMENT & EVLN.)

Q.NO	ANS	Q.NO	ANS	Q.NO	ANS	Q.NO	ANS	Q.NO	ANS
101	D	111	A	121	A	131	C	141	D
102	A	112	D	122	C	132	C	142	A
103	C	113	B	123	D	133	C	143	A
104	D	114	A	124	B	134	A	144	A
105	B	115	B	125	C	135	A	145	A
106	A	116	C	126	C	136	C	146	B
107	D	117	D	127	C	137	B	147	D
108	B	118	A	128	A	138	B	148	D
109	B	119	D	129	D	139	C	149	D
110	C	120	C	130	D	140	D	150	C

DN/21/MR

Date of Exam-01-09-2021



[PROVISIONAL]

BOARD OF SECONDARY EDUCATION:ODISHA:CUTTACK

OSSTET-2021
SCORING KEY

PAPER-II

SET-C

COMPULSORY (SECTION- I & II) (ODIA & ENGLISH)							
Q.NO	ANS	Q.NO	ANS	Q.NO	ANS	Q.NO	ANS
1	D	11	A	21	C	31	B
2	B	12	D	22	B	32	D
3	B	13	D	23	B	33	B
4	A	14	B	24	D	34	B
5	B	15	B	25	A	35	A
6	A	16	A	26	A	36	B
7	C	17	D	27	D	37	*G*
8	C	18	D	28	C	38	A
9	B	19	B	29	C	39	D
10	C	20	A	30	B	40	B

OPTIONAL (SECTION- III) (PHYSICAL EDUCATION)											
Q.NO	ANS	Q.NO	ANS	Q.NO	ANS	Q.NO	ANS	Q.NO	ANS	Q.NO	ANS
41	A	51	C	61	D	71	D	81	A	91	B
42	D	52	B	62	B	72	D	82	B	92	D
43	A	53	C	63	D	73	B	83	C	93	C
44	B	54	C	64	D	74	A	84	A	94	D
45	C	55	B	65	B	75	D	85	D	95	C
46	C	56	A	66	D	76	B	86	B	96	C
47	B	57	C	67	C	77	C	87	B	97	D
48	A	58	D	68	D	78	C	88	*G*	98	C
49	C	59	A	69	D	79	C	89	B	99	B
50	B	60	B	70	D	80	A	90	C	100	C

COMPULSORY (SECTION- IV) (CHILD DEVP., PEDAGOGY, S MANAGEMENT & EVLN.)									
Q.NO	ANS	Q.NO	ANS	Q.NO	ANS	Q.NO	ANS	Q.NO	ANS
101	A	111	C	121	A	131	D	141	C
102	C	112	D	122	C	132	D	142	B
103	D	113	B	123	B	133	A	143	B
104	A	114	C	124	A	134	A	144	A
105	A	115	C	125	D	135	C	145	D
106	D	116	D	126	C	136	C	146	C
107	A	117	A	127	D	137	A	147	C
108	D	118	C	128	B	138	A	148	D
109	B	119	C	129	D	139	B	149	D
110	A	120	B	130	B	140	D	150	C

Date of Exam-01-09-2021



[PROVISIONAL]

BOARD OF SECONDARY EDUCATION:ODISHA:CUTTACK

OSSTET-2021
SCORING KEY

PAPER-II

SET-D

COMPULSORY (SECTION- I & II) (ODIA & ENGLISH)							
Q.NO	ANS	Q.NO	ANS	Q.NO	ANS	Q.NO	ANS
1	B	11	A	21	A	31	B
2	D	12	D	22	D	32	B
3	B	13	C	23	C	33	A
4	B	14	D	24	B	34	B
5	A	15	A	25	B	35	B
6	D	16	D	26	B	36	*G*
7	B	17	A	27	C	37	B
8	C	18	B	28	D	38	D
9	A	19	B	29	A	39	A
10	B	20	C	30	C	40	D

OPTIONAL (SECTION- III) (PHYSICAL EDUCATION)											
Q.NO	ANS	Q.NO	ANS	Q.NO	ANS	Q.NO	ANS	Q.NO	ANS	Q.NO	ANS
41	D	51	C	61	D	71	A	81	B	91	C
42	B	52	D	62	D	72	C	82	B	92	D
43	D	53	C	63	C	73	A	83	D	93	C
44	B	54	D	64	A	74	C	84	D	94	A
45	C	55	A	65	A	75	B	85	B	95	C
46	*G*	56	B	66	C	76	B	86	C	96	C
47	B	57	B	67	A	77	D	87	B	97	B
48	C	58	C	68	D	78	A	88	B	98	B
49	C	59	D	69	C	79	D	89	D	99	A
50	D	60	C	70	B	80	B	90	D	100	C

COMPULSORY (SECTION- IV) (CHILD DEVP., PEDAGOGY, S MANAGEMENT & EVLN.)									
Q.NO	ANS	Q.NO	ANS	Q.NO	ANS	Q.NO	ANS	Q.NO	ANS
101	C	111	B	121	B	131	C	141	B
102	D	112	C	122	C	132	C	142	B
103	A	113	D	123	D	133	D	143	C
104	A	114	B	124	D	134	D	144	A
105	A	115	D	125	A	135	B	145	C
106	C	116	A	126	A	136	D	146	A
107	D	117	D	127	C	137	B	147	D
108	B	118	A	128	C	138	A	148	C
109	D	119	C	129	A	139	C	149	A
110	D	120	A	130	B	140	C	150	D